

PHILIPS

DATA
HANDBOOK



ELECTRONIC COMPONENTS
AND MATERIALS

COMPONENTS AND MATERIALS

PART 6

AUGUST 1971

Electric motors and accessories

Timing and control devices

COMPONENTS AND MATERIALS

Part 6

August 1971

I "Electric motors and accessories" (Polymotor)

Small synchronous motors	A
--------------------------	---

Stepper motors	B
----------------	---

Small d.c. motors	C
-------------------	---

Tachogenerators and servomotors	D
---------------------------------	---

Asynchronous motors	E
---------------------	---

II "Timing and control devices" (A.W. Haydon)

Indicators for built-in test equipment (bite)	F
---	---

Time indicators, timers, timing motors	G
--	---

Comprehensive contents list at the back

DATA HANDBOOK SYSTEM

To provide you with a comprehensive source of information on electronic components, subassemblies and materials, our Data Handbook System is made up of three series of handbooks, each comprising several parts.

The three series, identified by the colours noted, are:

ELECTRON TUBES (9 parts) BLUE

SEMICONDUCTORS AND INTEGRATED CIRCUITS (5 parts) RED

COMPONENTS AND MATERIALS (6 parts) GREEN

The several parts contain all pertinent data available at the time of publication, and each is revised and reissued annually; the contents of each series are summarized on the following pages.

We have made every effort to ensure that each series is as accurate, comprehensive and up-to-date as possible, and we hope you will find it to be a valuable source of reference. Where ratings or specifications quoted differ from those published in the preceding edition they will be pointed out by arrows. You will understand that we can not guarantee that all products listed in any one edition of the handbook will remain available, or that their specifications will not be changed, before the next edition is published. If you need confirmation that the published data about any of our products are the latest available, may we ask that you contact our representative. He is at your service and will be glad to answer your inquiries.

ELECTRON TUBES (BLUE SERIES)

This series consists of the following parts, issued on the dates indicated.

Part 1		January 1971
Transmitting tubes (Tetrodes, Pentodes)	Associated accessories	
Part 2		March 1971
Tubes for microwave equipment		
Part 3		March 1970
Special Quality tubes	Miscellaneous devices	
Part 4		April 1971
Receiving tubes		
Part 5		May 1971
Cathode-ray tubes	Photoconductive devices	
Photo tubes	Associated accessories	
Camera tubes		
Part 6		June 1971
Photomultipliers tubes	Radiation counter tubes	
Channel electron multipliers	Semiconductor radiation detectors	
Scintillators	Neutron generator tubes	
Photoscintillators	Photo diodes	
	Associated accessories	
Part 7		July 1971
Voltage stabilizing and reference tubes	Thyratrons	
Counter, selector, and indicator tubes	Ignitrons	
Trigger tubes	Industrial rectifying tubes	
Switching diodes	High-voltage rectifying tubes	
Part 8		August 1970
T. V. Picture tubes		
Part 9		January 1971
Transmitting tubes (Triodes)	Associated accessories	
Tubes for R. F. heating (Triodes)		

June 1971

SEMICONDUCTORS AND INTEGRATED CIRCUITS (RED SERIES)

This series consists of the following parts, issued on the dates indicated.

Part 1 Diodes and Thyristors September 1970

General	Rectifier diodes
Signal diodes	Thyristors, diacs, triacs
Tunnel diodes	Rectifier stacks
Variable capacitance diodes	Accessories
Voltage regulator diodes	Heatsinks

Part 2 Low frequency; Deflection October 1970

General	Deflection transistors
Low frequency transistors (low power)	Accessories
Low frequency power transistors	

Part 3 High frequency; Switching November 1970

General	Switching transistors
High frequency transistors	Accessories

Part 4 Special types December 1970

General	Beam lead devices for
Transmitting transistors	thick- and thin-film circuits
Microwave devices	Photo devices
Field effect transistors	Accessories
Dual transistors	
Microminiature devices for	
thick- and thin-film circuits	

Part 5 Integrated Circuits March 1971

General	Linear integrated circuits
Digital integrated circuits	
DTL (FC family)	
TTL (FJ family)	
MOS (FD family)	

COMPONENTS AND MATERIALS (GREEN SERIES)

This series consists of the following parts, issued on the dates indicated.

Part 1 Circuit Blocks, Input/Output Devices **September 1970**

Circuit blocks 100 kHz Series	Norbits 60-Series, 61-Series
Circuit blocks 1-Series	Circuit blocks 90-Series
Circuit blocks 10-Series	Circuit blocks for ferrite core memory drive
Circuit blocks 20-Series	Input/output devices
Circuit blocks 40-Series	
Counter modules 50-Series	

Part 2 Resistors, Capacitors **December 1970**

Fixed resistors	Polycarbonate, paper, mica, polystyrene capacitors
Variable resistors	Electrolytic capacitors
Non-linear resistors	Variable capacitors
Ceramic capacitors	

Part 3 Radio, Audio, Television **February 1971**

FM tuners	Audio and mains transformers
Coils	Television tuners
Piezoelectric ceramic resonators and filters	Components for black and white television
Loudspeakers	Components for colour television
	Deflection assemblies for camera tubes

Part 4 Magnetic Materials, Piezoelectric Ceramics **April 1971**

Ferrites for radio, audio and television	Ferroxcube potcores and square cores
Small coils, assemblies and assembling parts	Ferroxcube transformer cores
	Piezoxide
	Permanent magnet materials

Part 5 Memory Products, Magnetic Heads, Quartz Crystals, Microwave Devices, Variable Transformers, Electro-mechanical Components **June 1971**

Ferrite memory cores	Quartz crystal units, crystal filters
Matrix planes, matrix stacks	Isolators, circulators
Complete memories	Variable mains transformers
Magnetic heads	Electro-mechanical components

Part 6 Electric Motors and Accessories, Timing and Control Devices **August 1971**

Stepper motors	Small d. c. motors
Small synchronous motors	Tachogenerators and servomotors
Asynchronous motors	Indicators for built-in test equipment

Technology relating to the products described in this publication is shared by the following companies.

Australia

PHILIPS INDUSTRIES Ltd.
20, Herbert Street
Artarmon (N.S.W.)

Austria

WIENER RADIOWERKE G.m.b.H.
P.o.b. 111
A 1072 Wien

Belgium

M.B.L.E.
80, Rue des Deux Gares
1070 Brussels

Canada

PHILIPS ELECTRONIC INDUSTRIES Ltd.
Côte de Liesse Road 5930
Montreal

Denmark

MINIWATT A.S.
Emdrupvej 115
DK-2400 København N.V.

Finland

ELCOMA
P.O. 10255
Helsinki 10

France

POLYMOTOR SEDELEM
14, Passage Charles Dalléry
Paris XIe

Germany

VALVO G.m.b.H.
Burchardstrasse 19
2 Hamburg 1

Israel

ISRALECTRA Ltd.
12, Allenby Road
Haifa

Italy

POLYMOTOR ITALIANA
Via Vittor Pisani 31
Milano

Japan

PHILIPS PRODUCT SALES CORP. OF JAPAN
World Trade Center Bldg, 32nd floor
5, 3-chome, Shiba Hamamatsu-cho
Minato-ku
Tokyo

New Zealand

EDAC Ltd.
70-72 Kingsford Smith Street
Wellington

Netherlands

PHILIPS NEDERLAND N.V.
Gebouw VB - Elonco Dept.
Eindhoven

Norway

ELECTRONICA A.S.
Postboks 5220
Oslo 3

South-Africa

EDAC (Pty) Ltd.
South Park Lane
New Doornfontein
Johannesburg

Spain

COPRESA S.A.
Balmes 22
Barcelona 7

Switzerland

PHILIPS A.G.
CH 8027
Zürich 3/45

Sweden

A.B. ELCOMA
Lidingövägen 50 Fack
Stockholm 27

United Kingdom

IMPEX ELECTRICAL Ltd.
Market Road
Richmond (Surrey)

U.S.A.

THE A.W. HAYDON COMPANY
232, North Elm Street
Waterbury (Conn.)

Other Countries

POLYMOTOR INTERNATIONAL
1, Boulevard Anspach
1000 Brussels, Belgium
Tel. 192746
Telex: 23203 Polymotor

This book describes two groups of products: "Electric motors and accessories" are Polymotor products, "Timing and control devices" are manufactured by the A. W. Haydon Company.

Some general remarks:

- All mechanical drawings have been laid out according to the European projection method.
- The dimensions of the products are given in mm, unless otherwise stated.
- Forces are given in grams (g); $100 \text{ g} = 1 \text{ Newton (N)} = 3.53 \text{ ounce (oz)}$
- Torques are given in gramcentimetre (gcm); $100 \text{ gcm} = 0.01 \text{ Newtonmeter (Nm)} = 1.39 \text{ ounce inch (oz. in)}$
- For ordering our products please use their catalogue number; accessories such as phasing capacitors, brackets and inverters should be ordered with a separate order sheet, unless otherwise indicated.
- The information given in this book does not imply a license under any patent.

**I ELECTRIC MOTORS
AND ACCESSORIES (POLYMOTOR)**

Small synchronous motors



General	page A3
Unidirectional motors	page A19
Reversible motors	page A29
Synchrodriers	page A45
A.C./D.C. synchronous motors	page A51
Universal programme switch assembly kit	page A57
Gearboxes	page A61

PRINCIPLES

In a two-pole synchronous motor fitted with a permanent-magnet rotor, a sinusoidally alternating magnetic field is set up in the stator by the sinusoidal exciting current. The alternating field can be assumed to be the resultant of two magnetic fields of equal and constant strength but rotating in opposite directions. The vector diagram at a time t can then be drawn (Fig. below).

The constant fields are here represented by the vectors H_l and H_r . The permanent magnet (the rotor) can now follow either the field rotating counterclockwise or the one rotating clockwise. Fundamentally, therefore, a synchronous motor can rotate in either direction. However, more advanced constructions like our synchronous motors rotate in one direction which is determined electrically as will be explained later on.

During one cycle of the alternating supply current a motor with two poles, that is one pair of poles, will make one revolution. In a motor with p pole pairs the rotor turns through $360/p$ angular degrees. The speed of the motor is thus determined by the frequency and the number of pole pairs and can be calculated with the formula:

$$n = \frac{60f}{p} \text{ rev/min}$$

where f = frequency and p = number of pole pairs.

PERMANENT-MAGNETIC ROTOR

As described above, the speed of the motor is governed by the number of pole pairs. How many pole pairs can be provided on a magnet ring depends on the space available along the periphery of the ring, and on the properties of the magnetic material. The magnetic material is characterized by a high coercive force so that a great number of poles can be accommodated in a small space. Moreover, the residual flux will not be attenuated by the alternating field. In our synchronous motors as many as 24 poles can be made along the periphery of the magnet ring. Thus, the speed of these motors operating from 50 Hz mains is:

$$n = \frac{60 \times 50}{12} = 250 \text{ rev/min}$$

and with 60 Hz mains:

$$n = \frac{60 \times 60}{12} = 300 \text{ rev/min}$$

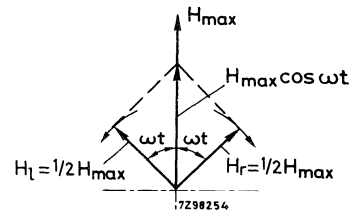

The low motor speed means that for most applications the gearing-down ratio can be very small. This results in gearboxes of simple design which show very little wear in the bearings.

SYNCHRONOUS MOTORS WITH A SINGLE CONSTANT ROTATING FIELD

The figure below shows the situation at a time t in a synchronous motor with an auxiliary field added. Both the main field and the auxiliary one are again represented as being the resultant of two magnetic fields of equal and constant strength but rotating in opposite directions.

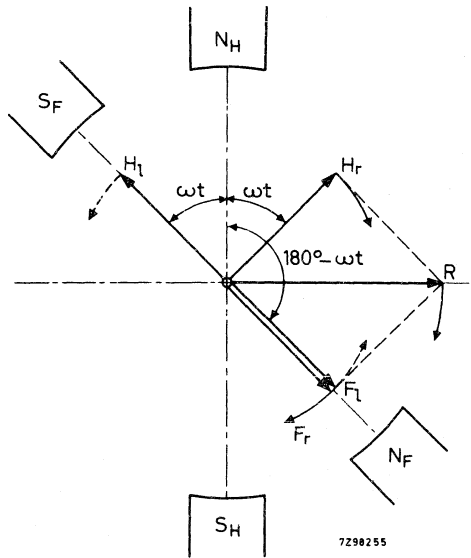

The main field, which changes sinusoidally, is represented by the vectors H_1 and H_r . The poles of the main field are indicated by N_H and S_H . If the rotor is driven by, for example, H_r (clockwise), then H_1 (counterclockwise) will give rise to a vibration at double the frequency of the main field. To control the rotation of the motor and, as in this example, make it run clockwise only, and to eliminate the vibration at the same time, H_1 must be eliminated. This can be achieved by the compensating or auxiliary field F (with its component fields F_1 and F_r , identical and rotating in opposite directions), between poles N_F and S_F . We see that F_1 , rotating counterclockwise, will always oppose H_1 (also counterclockwise), and even eliminate it when fields H and F are of equal strength. We also see that F_r and H_r combine to the resulting rotating field R . The rotor will rotate in the direction of R because it is the only remaining field. Evidently R can also be chosen such that the motor can only run counterclockwise.

Finally, we see that in the figures the auxiliary field F lags behind the main field H by an angle (phase shift) ωt .

The above explanation applies to a two-pole motor; in motors with more poles the auxiliary poles must be uniformly distributed between them.

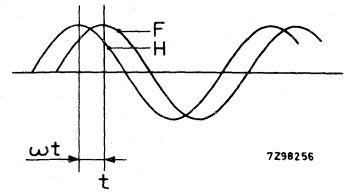

- Two methods are available for obtaining a single constant rotating magnetic field;
- an auxiliary lagging field is derived from the main field; our unidirectional motors operate on this principle (see below)
 - two stators are used yielding alternating fields with a certain phase shift between them, as in our reversible types of motors (see the next page).

SYNCHRONOUS MOTORS WITH ONE DIRECTION OF ROTATION (catalogue numbers 9904 110

All these motors are provided with a copper ring around each of the auxiliary poles. The effect is that an induction current is produced through the rings, lagging behind the voltage E_2 (induced by the field ϕ_{H_2}). The induced magnetic flux ϕ_2 forms with the main flux ϕ_{H_2} the desired auxiliary flux ϕ_F , which lags behind the main flux, ϕ_{H_2} , by the angle α . The construction is such that the auxiliary field, though weaker than the main field, ensures unidirectional operation of the motor.

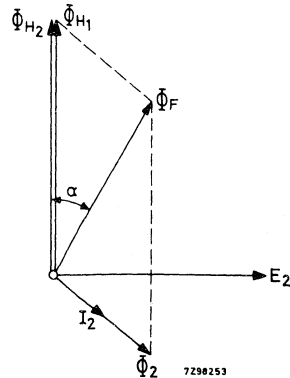
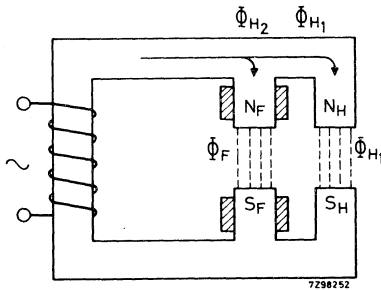

SYNCHRONOUS MOTORS WITH AN ELECTRICALLY REVERSIBLE DIRECTION OF ROTATION (catalogue numbers 9904 111)

As mentioned on the preceding page, the rotation of a synchronous motor can be made stable by incorporating two stators in one casing. The required phase shift is obtained by means of a capacitor which can be connected in series with either stator coil.

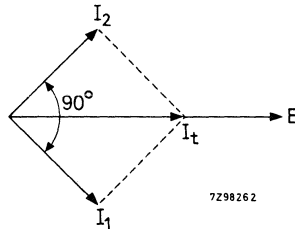
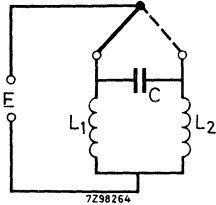

Current I_1 in coil L_1 will lag behind voltage E by 45° . With the aid of a capacitor, current I_2 in coil L_2 can be made to lead the voltage by 45° , giving a phase angle between I_1 and I_2 of 90° . The total current I_t will then be approximately in phase with the voltage so that the maximum torque, and hence a high efficiency, is attained at a very low power consumption. From the above explanation it follows that the poles of the two stators must be an angle of $180-90^\circ$ apart.

With L_1 and L_2 in parallel, as above, either the intersection of L_1 and the capacitor, or of L_2 and the capacitor, can be connected to the supply. Switching over will, however, reverse the rotation of the motor.

An arrangement with the two stator coils connected in series is also possible; this point is dealt with in some detail in the next subsection.

PARALLEL AND SERIES CONNECTION OF THE STATOR COILS IN REVERSIBLE MOTORS

The reversible synchronous motors can be made to produce a higher torque by connecting the stator coils in series, with the exception of the type 9904 111 06... which is available only with parallel-connected coils.

The figures below show the circuit diagrams.

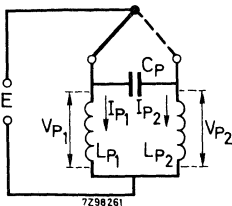

Parallel-connected stator coils

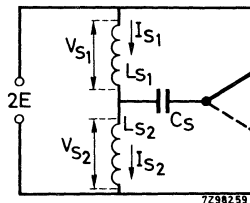

Series-connected stator coils

With series-connected coils the motors require about double the supply voltage.

Evidently a motor suitable for operation from a 24-volt source with parallel-connected coils may be operated from a 48-volt source when the coils are connected in series. In this way we get:

parallel-connection

24 V
48 V
110 V
220 V

series-connection

48 V
110 V
220 V
380 V

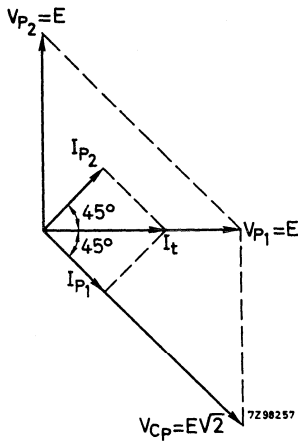

Vector diagram for parallel-connected stator coils

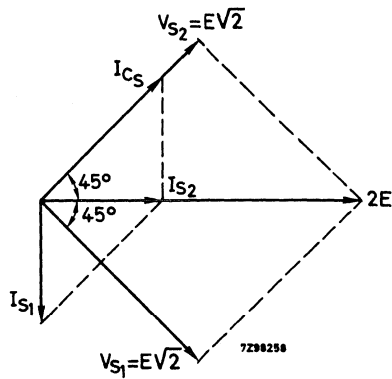

Vector diagram for series-connected stator coils

The vector diagrams show that the voltage across each coil in the series arrangement is $\sqrt{2}$ times that in the parallel arrangement. The same is true of the current through each coil. Therefore the maximum torque produced by a motor with series-connected coils is considerably higher than that of a motor with parallel-connected coils.

However, not only the torque but the power consumption as well increases in the case of series connection. This is accompanied by a rise in the temperature of the stator coils (ΔT). As most of the materials used in the motors cannot withstand a temperature exceeding 110 °C, users of reversible motors with series-connected coils will have to make sure that the sum of the ambient temperature and ΔT never exceeds 110 °C, when the motors are in continuous operation.

With intermittent operation a higher ambient temperature may be acceptable, depending on the ratio between "switched-on time" and "switched-off time". We think it wise to explain this point to you with the aid of Figs. a, b and c.

Fig.a shows, for the motor type 9904 111 05311, with series-connected coils, the warm-up and cool-down curves; the maximum temperature rise occurs in the coils after about 90 minutes of continuous operation (see also the Note). Fig.b indicates that with a duty cycle of, say, 30 minutes, of which 20 minutes is switched-on time

and 10 minutes switched-off time, the coil temperature rises 49 °C after the first switched-on interval, then drops by 15 °C during the first switched-off interval, next rises again by 24 °C, etc., until eventually the maximum temperature rise of 60 °C is attained.

With the "total" temperature limit being 110 °C it is clear that this type of series-connected motor may be operated intermittently if the ambient temperature does not exceed $110 - 60 = 50$ °C.

Finally Fig.c shows the maximum permissible ambient temperature plotted as a function of the duty cycle for different on/off ratios. The upper limit is 70 °C (motor may be used Intermittently), the lower one is 40 °C (motor may be used continuously).

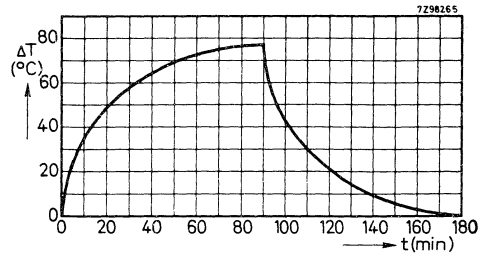

Fig.a

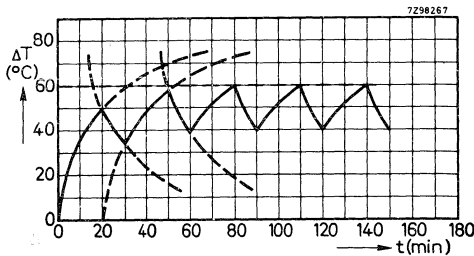

Fig.b

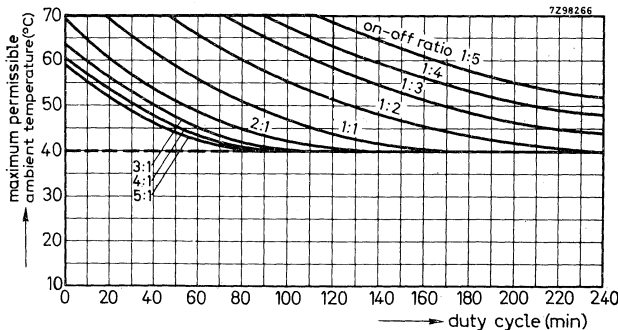

Fig.c

Note - The curve of Fig.a is measured on an arbitrary motor 9904 111 05311 at maximum supply voltage and with a phasing capacitor with maximum value. For other motors and/or in other circumstances the temperature rise (ΔT) can be lower or higher.

STARTING CHARACTERISTICS

Among the factors determining how fast synchronous motors using permanent magnets will start and whether the direction of rotation is correct, the following two deserve our attention:

- the loading conditions
- the relative positions of stator and rotor upon starting.

Loading may be as follows:

1. No load is present.
2. The torques are equal in both directions of rotation but they are below the maximum available motor torque.
3. The clockwise torque is equal to the maximum available motor torque but the counterclockwise torque is much lower.
4. The counterclockwise torque is infinitely high (that is: a mechanical stop is applied) but the clockwise torque equals the maximum available motor torque.
5. A torque is placed on the motor even when it is not energized (the load takes the form of a spring) but it does not exceed the motor's stalling torque.
6. The load has a high moment of inertia.

These loads can be applied directly to the motor spindle or via gears. In the latter case there will normally exist some backlash between the gearwheels which is sufficient to enable the motor to start in the unloaded mode and there will be no difficulty in handling the loads except in case 5. This is a special case because one can never be sure that a smooth start in the desired direction is made. To understand this we must realize that before the motor is excited the load torque equals a holding torque produced by the motor's magnetic circuit, otherwise the rotor would turn round. When the supply voltage is switched on, the holding torque may be reduced which will result in the motor being driven in the wrong direction by the load torque. The field operating in the wrong direction will have to be suppressed first.

The above phenomenon is most pronounced in unidirectional motors with the auxiliary field derived from the main one; the constant rotating field motors with two stator coils are less sensitive to it. In extreme cases it will be necessary to introduce a mechanical stop to neutralize the effect.

In case 6 the high inertia moment, when placed direct on the spindle, may cause the load not to be accelerated enough to reach synchronous speed; the rotor may then oscillate. Given sufficient amplitude these oscillations may after a longer or shorter time - depending on the nature and magnitude of the load, and on the motor excitation - develop into a steady rotation. The sense of rotation is determined by the direction of the oscillation which is the first to attain the necessary maximum. Hence it may well happen that the motor starts running in the wrong direction. It will continue to do so when the load in this direction is small enough. To avoid this effect one must make sure that the inertia moment of the load does not surpass a certain maximum.

Stronger motors are hampered by the inertia moment of the rotor which is so high that not much is left for the load. For this reason the motors 9904 111 06... have been equipped with a so-called resonance rotor, with a flexible connection between rotor and spindle. The rotation of this rotor upon switching-on is first an oscillating one but here too the oscillations develop into the steady rotation. Thanks to this rotor construction this type of motor starts rapidly, practically noiseless and without vibrations.

Laboratory measurements have demonstrated that unidirectional motors when starting under adverse loads need a starting time of about 250 ms. However, in most cases the starting time is considerably shorter. Twin-stator types of electrically reversible motors need, under adverse conditions, a starting time of about 80 ms.

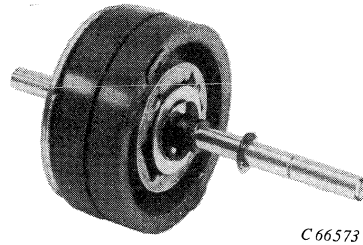

Resonance rotor

Note

The mass inertia moment of the pinion can be calculated with the formula

$$J = \frac{\pi}{32} \times \gamma \times h \times (D^4 - d^4)$$

for an annular object (see the sketch alongside) with

- outer diameter (D) in cm
- inner diameter (d) in cm
- height (h) in cm
- specific gravity (γ) in g/cm³

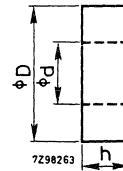

In the case of a pinion we may have;

- D = 4 mm (outer diameter over the teeth; this simplifies the calculation and provides a safety margin)
- d = 1.6 mm (spindle diameter)
- h = 4.5 mm
- specific gravity = 7.6 g/cm³

Its mass inertia moment may then work out to be 0.0086 gcm².

Any pinion with an outer diameter smaller than that of the centring rim on the motor will, as a rule, have a sufficiently small inertia moment.

SOME NOTES ON THE STRAY FIELD

For the major part our synchronous motors are provided with a steel casing which minimizes the stray field. Exceptions are the types 9904 111 05... and 9904 111 06....

The strength of a stray field decreases as a function of the distance from the motor. It can be determined by measuring the e.m.f. induced in a coil placed in the stray field, and using the formula:

$$H_{\text{eff}} = C \times e_{\text{eff}}$$

where H_{eff} = effective value of the field strength at the location of the measuring coil

C = a constant representing the size and the number of turns of the coil
(can be found by calculation or calibration)

e_{eff} = value read from the tube voltmeter.

Example: In the case of the 9904 111 06211 motor the following values were determined:

at the motor casing: 71 Oe

at 1 cm distance : 12.4 Oe

at 2 cm distance : 4.7 Oe

SOME MECHANICAL NOTES

Braking torque

In all the types of synchronous motor a considerable braking torque is produced when the current is interrupted due to the strong rotor magnet poles moving closely to the stator poles. The rotor is strongly braked, so that the motor stops almost immediately.

The angle through which the rotor can still turn after switching off depends on the magnitude and moments of inertia of the load. In normal use it will not be more than 20°. For most applications additional mechanical brakes are, therefore, not required.

Bearings

It has been found that the following materials were best suitable for manufacturing bearings of sound construction and meeting the wide variety of demands imposed on the motors.

1. Plastic slide bearings

- a. A polyamide of a high quality with a very finely graded emulsion of molybdenum disulphide (MoS₂) which gives self-lubricating properties, is used in the types 9904 110 02..., 9904 110 04... and 9904 110 05... motors.

Water absorption: negligible (<1.5%).

Coefficient of friction: low (<0.15), so the losses due to friction are very small. Chemical resistance: very high; it is resistant to the normal organic solvents, esters, ketones, lubricating oil, petrol, paraffin, and solutions of organic salts.

- b. P.T.F.E. This material is used in the motor type for high temperatures, 9904 110 03....

2. Sintered-metal slide bearings

- a. Sintered-bronze self-aligning slide bearings are used in the types 9904 111 04 ... and 9904 111 07... motors.

- b. Sintered-iron is used in the type 9904 111 06... motors.

3. Needle bearings

These bearings are used in the type 9904 111 05... motors.

MEASURING THE MOTOR TORQUE

The adjoining sketch illustrates the set-up for measuring the maximum motor torque. A pulley with diameter D is placed on the spindle, and a string is fastened at one end around the pulley and at the other to a helical spring with diameter d .

Next the motor is started, and it will wind the string around the pulley thereby stretching the spring. This goes on until the force exerted by the spring equals the maximum motor torque. Then the motor stops and Δl , that is the total displacement of a needle fixed to the spring, is measured.

With the aid of the formula: $M = (\frac{1}{2}D + \frac{1}{2}d) \times C \times \Delta l$ the motor torque can be calculated, where C is a constant characteristic for the spring and Δl is the displacement of the needle.

It is also possible to mark the scale in such a way that the motor torque can be read directly from it. Attention should be paid to the fact that the mass of the pulley should be as small as possible for accurate results.

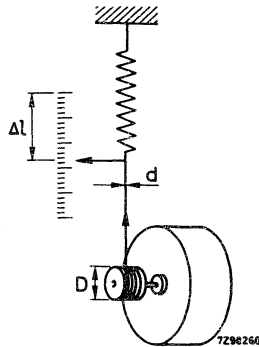

QUALITY CONTROL

Quality control is the prime concern from the moment a development is started until the product has been series-produced.

Thus, checks are carried out:

- during the development by testing the most important properties,
- at the end of development by approval tests on hand-made samples to make sure that the motor conforms to specifications; there is a standard programme of checks and tests subdivided into six groups (see below),
- during the first trial run in the factory, when the same programme of tests is carried out,
- during manufacture, when sometimes all individual products are tested, sometimes random tests are conducted.

The finished product is examined by an independent testing organization making random tests thus checking whether the manufacturer's quality control is up to standard. Also, any complaints on the part of customers are investigated by the quality department of the factory and by the independent testing organization.

There is a great difference between the tests carried out before full production starts and those performed during production, as becomes clear from the schedules given below.

QUALITY CONTROL BEFORE MANUFACTURING STARTS

The following so-called "release approval" tests are made:

1. Functional tests

The motors are subjected to:

- voltage fluctuations between -10 and +10% or between -15 and +10%
- on-off switching, up to 250 000 times
- a functional test at -20 °C, unless otherwise specified.

2. Tests on the resistance to damage during transport

These tests comprise:

- simulated transport tests on packed motors
- bump tests on motors mounted on a frame.

3. Climatic tests

To examine the behaviour of the motors under various conditions of shelving, the motors are subjected to:

- a temperature-cycle test, -40 to +85 °C, 30% R.H. (30 hours)
- a cycle damp test, 6 days
- a cold dry shelf test at -40 °C (16 hours), unless otherwise specified.

4. Life tests

No system of life tests yet devised gives a sure approval of the conduct of the motors over a long period. Some insight is gained from standard life tests and, in addition, a number of motors are operated for years at the rated voltage and under normal climatic conditions, both loaded and unloaded. The combination of life tests and practical experience gives a reasonable basis for predicting the motor life.

The standard life tests are not intended to cover the whole normal service life, because this would imply extremely prolonged test periods. Extrapolation of the test results allows us to assure that our synchronous motors are fit for continuous service for many years.

The standard life tests are as follows:

- operation for 2000 hours at room temperature and maximum load
- operation for 2000 hours at 70 °C unless otherwise specified and 70% of maximum load.

5. Dimensional checks

The product is checked visually; the dimensions are compared with those specified on the drawings.

6. Checks on whether the safety requirements are met

The motors should comply with the safety requirements according to CEE 10, Class 2 except motor 9904 110 05... which comes under CEE 10, Class 1. Examples of the requirements are: air gaps - 8 mm; creeping distances - 8 mm; high voltages - 2500 V between live parts and casing, for one minute. The connecting wires for all 60 Hz motors should be in accordance with CSA and UL requirements.

QUALITY CONTROL DURING PRODUCTION

The following tests are performed during production:

1. Random checks on motor components.
2. Random checks on sub-assemblies for the motor.
3. Tests during manufacturing, on such properties as:
 - direction of rotation
 - current
 - torque
 - spindle deviation
 - height of motor
 - resistance to insulation test voltage as given in the technical performance.

All the products are checked for major defects according to MIL standard 105, inspection level II, AQL: 1%.

LIFE

It is very difficult to give an exact value for the expected life of our products since the circumstances in which they are used are often very different. Accelerated life tests can only give an indication.

There are accelerated life tests carried out during 2000 hours, including tests under high ambient temperatures. After these severe tests, the motors still have to conform to the specifications and to be able to work for a long time. Some "informal" tests are carried out; for example, one of the motors has run continuously for more than 5 years under full load under normal (dusty) conditions. No excessive wear or other undesirable results were noted.

RELIABILITY

Synchronous motors are mostly used in applications where they are required to operate for a long time and where failures are highly undesirable because many functions are controlled, as in the case of timers or programme switches. A synchronous motor must therefore be trouble-free. The only way to achieve high reliability is to use a very simple design and to check the quality during all phases of production.

Our motors have:

- no ratchets that wear out
- closed casings hence, the air gap between rotor and stator is protected
- a coil which is wound in a simple way
- a one-piece rotor moulded to the spindle
- been checked regularly during development and manufacture.

APPLICATIONS

The synchronous motors can be used in a wide range of applications.

Industrial

Different types of clocks:

- control clocks
- master clocks
- secondary clocks
- signal clocks
- rate change clocks
- switch clocks

Different types of time devices:

- delay relays
- time printers and stamps
- time checking devices
- time recorders
- time switches

Signal apparatus for air traffic control and waterway traffic control

Recording instruments

Electric stage control stands

Control equipment for the processing industry, and for heating and airconditioning installations

Remote control units

Programme switches

Entertainment

Record players

Slide projectors

Television selector units

Tape recorders

Toy drivers

Television sets

Domestic

Timers and programme switches for:

- defroster sections in refrigerators and deepfreezers
- washing machines
- dish washers
- cooking ranges and ovens
- ultraviolet lamps
- automatic vending machines.

Special synchronous motors with inverter for operation from d. c. sources can be used in:

- emergency equipment (standby)
- short-cycle d. c. timing devices
- d. c. -powered musical equipment
- d. c. control systems
- portable (measuring) instruments



REMARKS ON THE TECHNICAL DATA

- The current, power and temperature increase values are guidance values and are measured at 20 °C, in free circulating air and at nominal voltage
- The torque values are minimum ones (except those of the synchrodriver), for the values at nominal voltage see the performance graph
- Derating of torque is given in a percentage per deg C above the ambient temperature of 20 °C
- The curves of the performance graphs are measured on arbitrary motors and synchrodrivers of basic types; they apply also to the derived versions, e.g. curves of motor 9904 110 02101 apply also to motors 9904 110 02111, 9904 110 02121 and 9904 110 02131
- At low ambient temperature (< -5 °C) the moment in which the motors reach their synchronous speed will be delayed
- The sense of rotation, clockwise (cw) or counterclockwise (ccw), is that seen when looking towards the spindle as shown by the arrow.

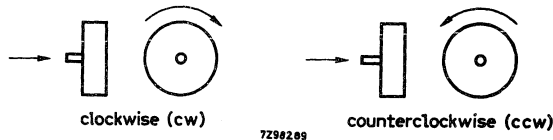

UNIDIRECTIONAL MOTORS

SURVEY

The range of unidirectional motors comprises the following types:

- standard type, catalogue number 9904 110 02...
- type for high ambient temperature, catalogue number 9904 110 03...
- under voltage type, catalogue number 9904 110 04...
- small type, catalogue number 9904 110 05...

Mounting brackets for these motors are given at the end of this section.

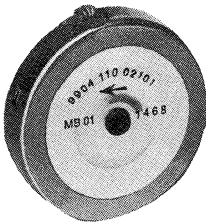

71 548 H5

Standard type, catalogue number 9904 110 02...

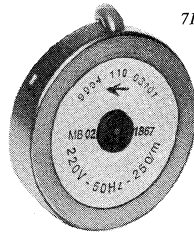

71 548 H3

Type for high ambient temperature, catalogue number 9904 110 03...

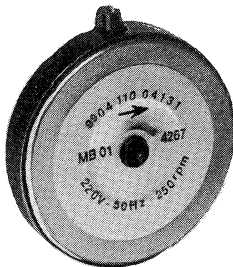

71 548 H4

Under-voltage type, catalogue number 9904 110 04...

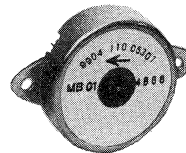

71 548 H7

Small type, catalogue number 9904 110 05...

STANDARD TYPE

TECHNICAL DATA

		catalogue number 9904 110 02...							
Plain version									
	clockwise rotation	001	101	201	301	401	501	601	701
	counterclockwise rotation	011	111	211	311	411	511	611	711
version with pinion									
	clockwise rotation	021	121	221	321	421	521	621	721
	counterclockwise rotation	031	131	231	331	431	531	631	731
Nominal voltage	(V)	220	220	117	110	48	24	12	6.3
Frequency	(Hz)	60	50	60	50	50	50	50	50
Speed	(rev/min)	300	250	300	250	250	250	250	250
Current	(mA)	11	7.5	22	17	40	73	170	230
Input power	(W)					1.6			
Starting torque	(gcm)					25			
Working torque	(gcm)					30			
Torque derating	(%)					0.6			
Temperature increase of the motor	(degC)					30			
Ambient temperature range	(°C)		-20 to +70						-20 to +50
Permissible voltage fluctuations	(%)					-15 to +10			
Insulation according to CEE10						class 2			
Insulation test voltage	(V)		2500						500
Bearings						slide bearings			
Maximum radial force	(g)					90			
Maximum axial force	(g)					50			
Maximum inertial load	(gcm ²)					0.15			
Housing						zinc plated			
Weight	(g)					90			

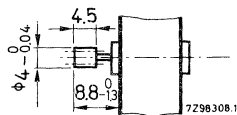
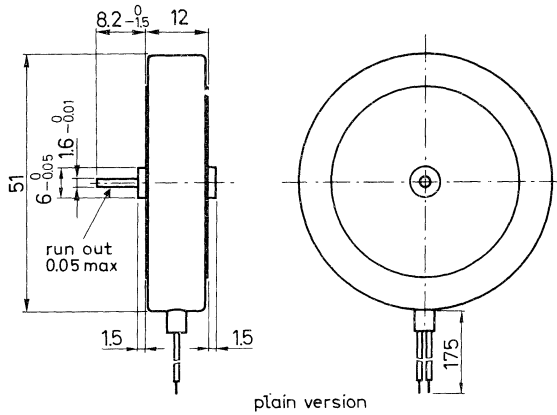
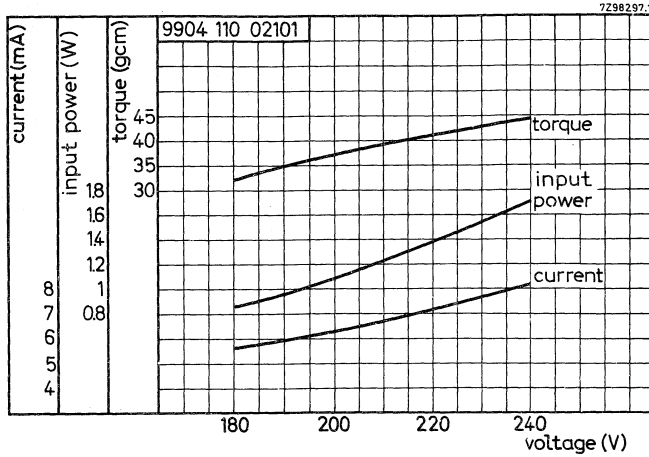

version with pinion
 number of teeth = 10
 module = 0.3
 addendum modification = +0.2

TYPE FOR HIGH AMBIENT TEMPERATURE

TECHNICAL DATA

		catalogue number
plain version		
clockwise rotation		9904 110 03101
counterclockwise rotation		9904 110 03111
Nominal voltage	(V)	220
Frequency	(Hz)	50
Speed	(rev/min)	250
Current	(mA)	11
Input power	(W)	2.2
Starting torque ¹⁾	(gcm)	15
Working torque ¹⁾	(gcm)	15
Torque derating	(%)	0.6
Temperature increase of the motor	(degC)	40
Ambient temperature range	(°C)	-20 to +120
Permissible voltage fluctuations	(%)	+15 to +10
Insulation according to CEE10		class 2
Insulation test voltage	(V)	2500
Bearings		slide bearings
Maximum radial force	(g)	50
Maximum axial force	(g)	10
Maximum inertial load	(gcm ²)	0.15
Housing		zinc plated
Weight	(g)	90

¹⁾ At ambient temperature of 120 °C

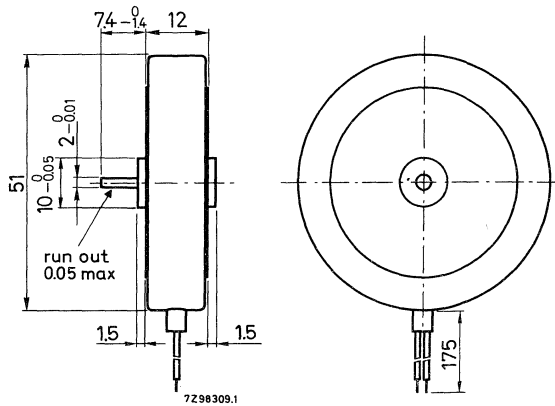
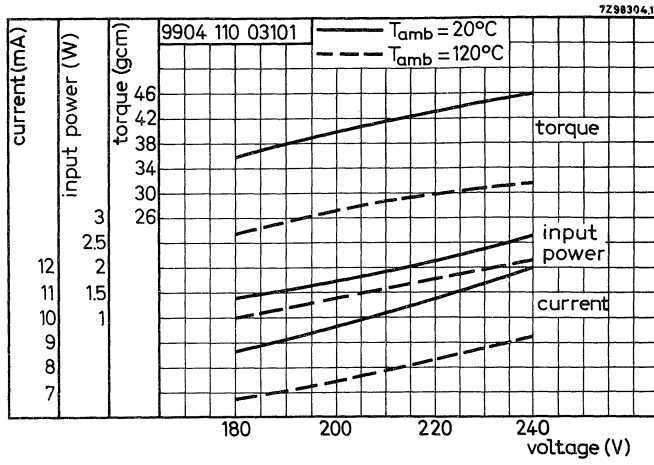

UNDER-VOLTAGE TYPE

TECHNICAL DATA

		catalogue number 9904 110 04...	
plain version			
	clockwise rotation	101	301
	counterclockwise rotation	111	311
version with pinion			
	clockwise rotation	121	
	counterclockwise rotation	131	
Nominal voltage	(V)	220	110
Frequency	(Hz)	50	50
Speed	(rev/min)	250	250
Current	(mA)	9	17
Input power	(W)	1.7	1.6
Starting torque	(gcm)		15
Working torque	(gcm)		15
Torque derating	(%)		0.6
Temperature increase of the motor	(degC)		30
Ambient temperature range	(°C)		-20 to +50
Permissible voltage fluctuations	(%)		-30 to +10
Insulation according to CEE10			class 2
Insulation test voltage	(V)		2500
Bearings			slide bearings
Maximum radial force	(g)		90
Maximum axial force	(g)		50
Maximum inertial load	(gcm ²)		0.15
Housing			zinc plated
Weight	(g)		90

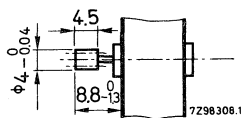
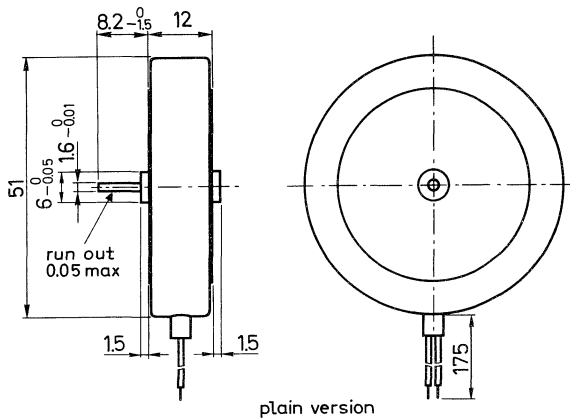
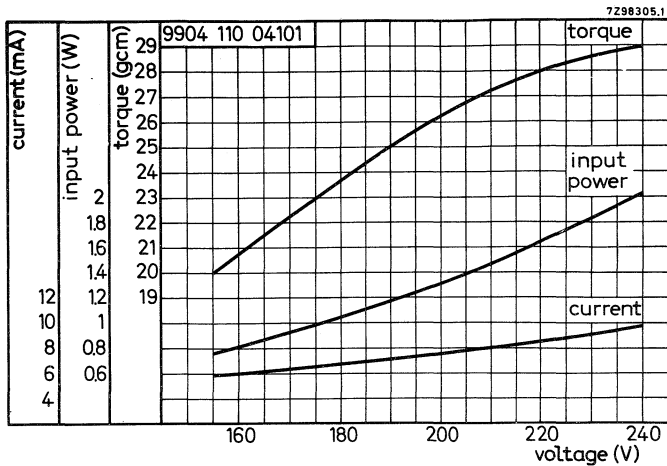

version with pinion

number of teeth = 10
 module = 0.3
 addendum modification = +0.2

SMALL TYPE

TECHNICAL DATA

		catalogue number 9904 110 05...						
plain version								
clockwise rotation	101 ¹⁾	201	301	401	501	601	701	
counterclockwise rotation	111 ¹⁾	211	311	411	511	611	711	
version with pinion								
clockwise rotation	121 ¹⁾	221	321	421	521	621	721	
counterclockwise rotation	131 ¹⁾	231	331	431	531	631	731	
Nominal voltage	(V)	220	117	110	48	24	12	6
Frequency	(Hz)	50	60	50	50	50	50	50
Speed	(rev/min)	250	300	250	250	250	250	250
Current	(mA)	8	8	5	12.5	24	70	100
Input power	(W)	1.8	0.9	0.5	0.6	0.5	0.8	0.6
Starting torque	(gcm)	5	5	5	5	5	5	5
Working torque	(gcm)	5	5	5	5	5	5	5
Torque derating	(%)	0.6	0.6	0.6	0.6	0.6	0.6	0.6
Temperature increase of the motor	(deg C)	20	35	20	25	20	30	25
Ambient temperature range	(°C)	-20 to +70						
Permissible voltage fluctuations	(%)	-15 to +10						
Insulation according to CEE10		class 1						
Insulation test voltage	(V)	2500						
Bearings		slide bearings						
Maximum radial force	(g)	30						
Maximum axial force	(g)	10						
Maximum inertial load	(gcm ²)	0.05						
Housing		zinc plated						
Weight	(g)	40						

¹⁾ With series resistor of 20 k Ω , 2 W.

Also available without resistor under catalogue number:

9904 110 05102, 9904 110 05112, 9904 110 05122 and 9904 110 05132 respectively.

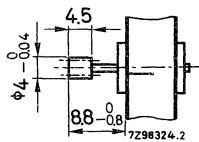
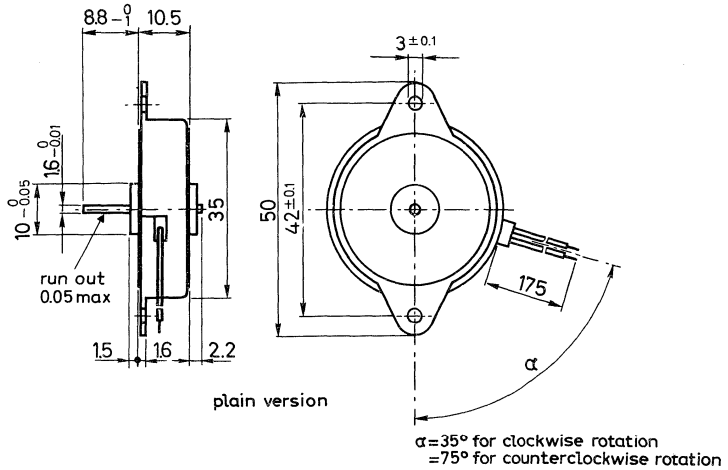
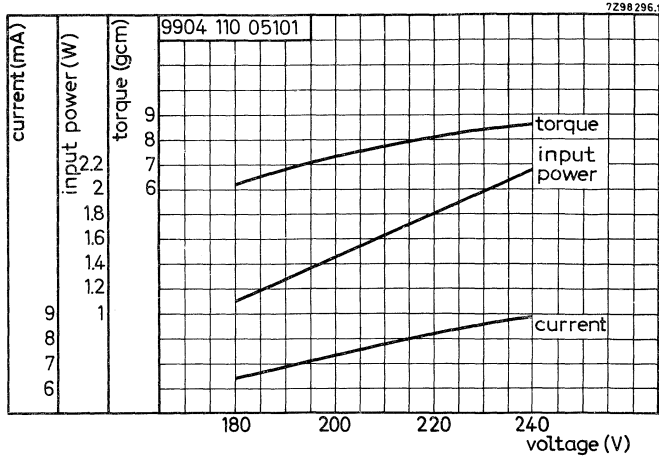

version with pinion
 number of teeth = 10
 module = 0.3
 addendum modification = +0.2

BRACKETS

Special brackets have been made available for mounting the motors of the series 9904 110 02..., 9904 110 03... and 9904 110 04... to some piece of equipment, which may be a gearbox.

They are identified as follows:

bracket 9904 131 01001 for use with motors of the series 9904 110 02... and 9904 110 04... (plain versions and versions with pinion)

bracket 9904 131 01003 for use with motors of the 9904 110 03... series.

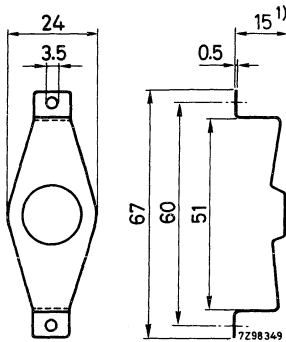

Bracket 9904 131 01001

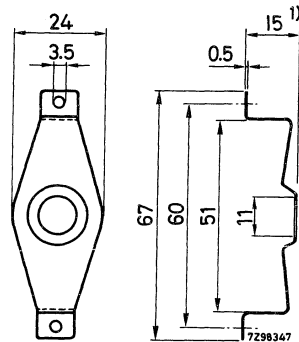

Bracket 9904 131 01003

¹⁾ In mounted position.

REVERSIBLE MOTORS

SURVEY

The range of reversible motors comprises the following types:

- medium torque type, catalogue number 9904 111 04...
- high torque type, catalogue number 9904 111 05...
- high torque, slender type, catalogue number 9904 111 06...
- small type, catalogue number 9904 111 07...

All these motors are supplied without phasing capacitors. For recommended capacitors see paragraph "Technical Data" of the relevant motors.

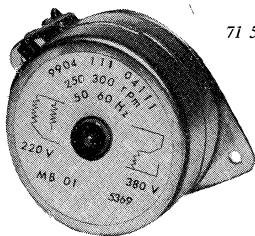

71 548 H6

Medium torque type,
catalogue number
9904 111 04...

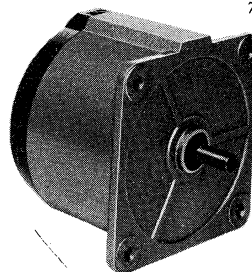

71 548 H1

High torque type,
catalogue number
9904 111 05...

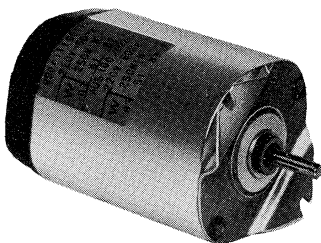

71 548 H2

High torque slender
type, catalogue
number 9904 111 06...

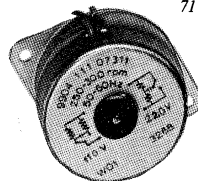

71 548 H8

Small type, catalogue
number 9904 111 07...

MEDIUM TORQUE TYPE

TECHNICAL DATA

		catalogue number 9904 111 04...									
		coils in parallel									
		111		311		411		511		611	
plain version		131		331		431		531		631	
version with pinion											
Nominal voltage	(V)	220		110	117	48		24		12	
Frequency	(Hz)	50	60	50	60	50	60	50	60	50	60
Speed	(rev/min)	250	300	250	300	250	300	250	300	250	300
Current	(mA)	8		18		38		75		155	
Input power	(W)	1.8									
Starting torque	(gcm)	100									
Working torque	(gcm)	100									
Torque derating	(%)	0.25									
Temperature increase of the motor	(degC)	25									
Ambient temperature range ¹⁾	(°C)	-20 to +70									
Permissible voltage fluctuations	(%)	-15 to +10									
Insulation according to CEE10		class 2									
Insulation test voltage	(V)	2500									
Bearings		slide bearings									
Maximum radial force	(g)	500									
Maximum axial force	(g)	150									
Housing		zinc plated									
Weight	(g)	160									
Required phasing capacitor	(µF)	0.056	0.039	0.22	0.18	1.2	1	4.7	3.3	18	14
Permissible a. c. voltage	(V)	330		250		160		63		160	
Catalogue number 2222		277 81563 ²⁾	277 81393	341 59224 ²⁾	341 59184 ²⁾	341 89125 ²⁾	341 89105	341 29475 ²⁾	341 29335	325 50186 ²⁾	325 50146 ²⁾

¹⁾ Continuous operation. Intermittent operation must allow for a maximum permissible stator temperature of 110 °C. See also paragraph "Parallel and series connection of the stator coils in reversible motors".

²⁾ Readily available.

catalogue number 9904 111 04...

coils in series

111 131		311 331		411 431		511 531		611 631	
380		220		110	117	48		24	
50	60	50	60	50	60	50	60	50	60
250	300	250	300	250	300	250	300	250	300
9		16		32		75		155	
3,5									
150									
150									
0.25									
50									
-20 to +50									
-15 to +10									
class 2									
2500									
slide bearings									
500									
150									
zinc plated									
160									
0.15	0.12	0.47	0.39	1.8	1.5	10	8	47	39
330		250		160		160			
277 71154	277 71124 (2)	341 59474 (2)	341 59394	341 89185	341 89155	325 50106	325 50805	325 50256 (2x)	325 50206 (2x)



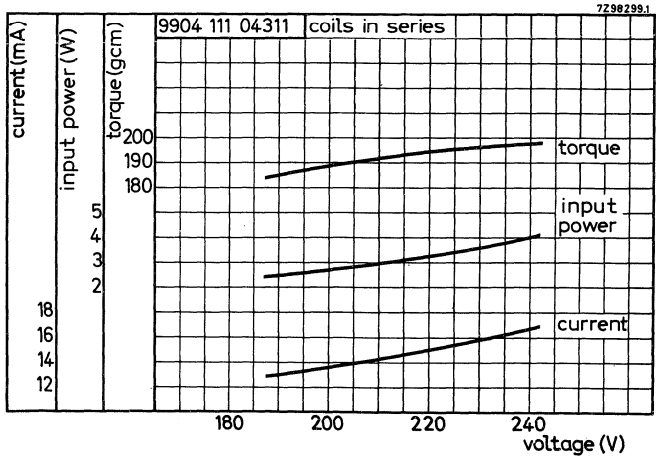
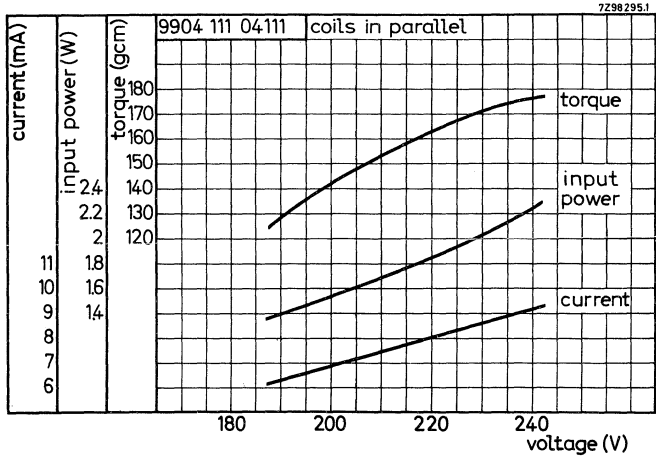

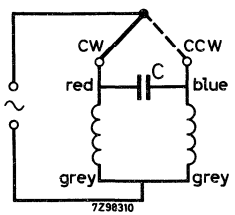
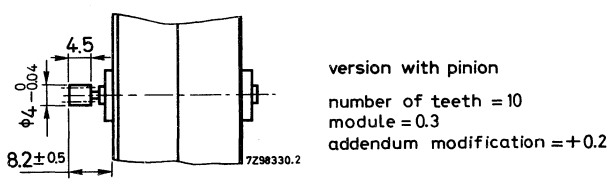
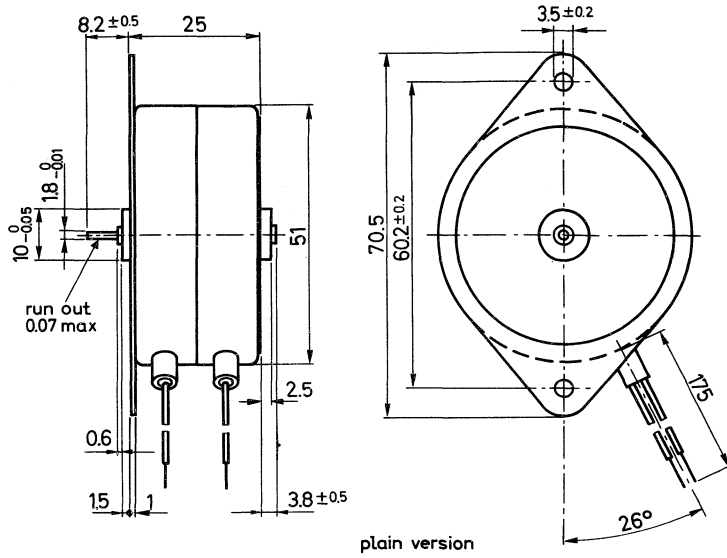

Coils in parallel

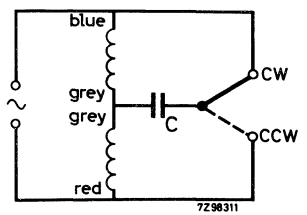

Coils in series

Connection diagrams

HIGH TORQUE TYPE

TECHNICAL DATA

plain version		catalogue number 9904 111 05...					
		coils in parallel					
		111	211	311	411	511	611
Nominal voltage	(V)	220	117	110	48	24	12
Frequency	(Hz)	50	60	50	50	50	50
Speed	(rev/min)	250	300	250	250	250	250
Current	(mA)	16	42	30	65	140	280
Input power	(W)	3.3	4.5	4.5	3.3	3.3	3.3
Starting torque	(gcm)	325	325	325	325	325	325
Working torque	(gcm)	375	375	375	375	375	375
Torque derating	(%)	0.25	0.25	0.25	0.25	0.25	0.25
Temperature increase of the motor	(degC)	40	50	40	40	40	40
Ambient temperature range ¹⁾	(°C)	-20 to +70					
Permissible voltage fluctuations	(%)	-15 to +10					
Insulation according to CEE10		class 2					
Insulation test voltage	(V)	2500					
Bearings		needle bearings					
Maximum radial force	(g)	1500					
Maximum axial force	(g)	500					
Housing		aluminium					
Weight	(g)	550					
Required phasing capacitor	(µF)	0.12	0.47	0.47	2.2	10	40
Permissible a.c. voltage	(V)	330	250	250	160	160	
Catalogue number							
2222							
		277 81124 ³⁾	341 59474 ³⁾	341 59474 ³⁾	341 89225 ³⁾	325 50106	

¹⁾ Continuous operation. Intermittent operation must allow for a maximum permissible stator temperature of 110 °C. See also paragraph "Parallel and series connection of the stator coils in reversible motors".

²⁾ With a 150 Ω ± 10%, 1.0 W resistor in series with each stator coil.

³⁾ Readily available.

catalogue number 9904 111 05...

coils in series

111	211	311	411	511	611
380	220	220	110 ²⁾	48	24
50	60	50	50	50	50
250	300	250	250	250	250
10	27	30	70	110	250
3.7	6	6	7.5	7.5	6
400	550	550	550	550	550
450	600	600	600	600	600
0.25	0.25	0.25	0.25	0.25	0.25
45	60	60	60	55	60

-20 to +40

-15 to +10

class 2

2500

needle bearings

1500

500

aluminium

550

0.18	0.68	0.82	4	16	60
330	250	250	160	160	
277 71184 ³⁾	341 59684	341 59824	325 50405	325 50166	325 50206 (3x)

7298298.1

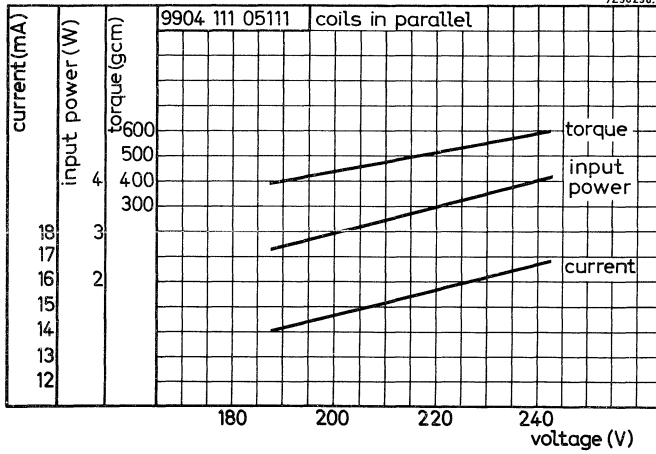

7298301.1

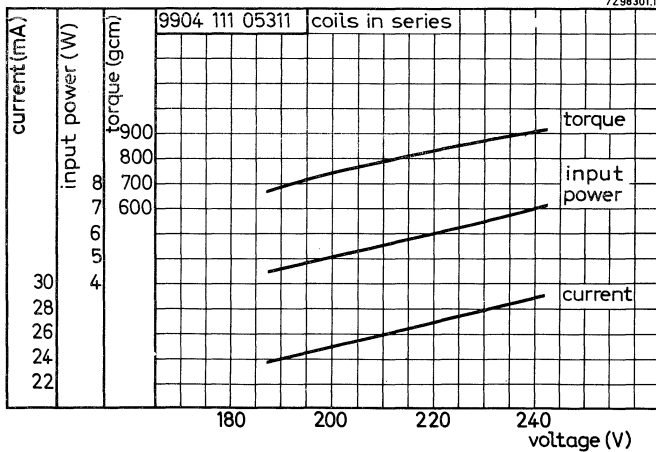

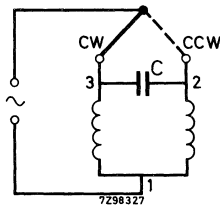
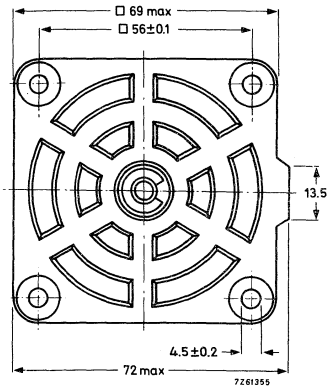
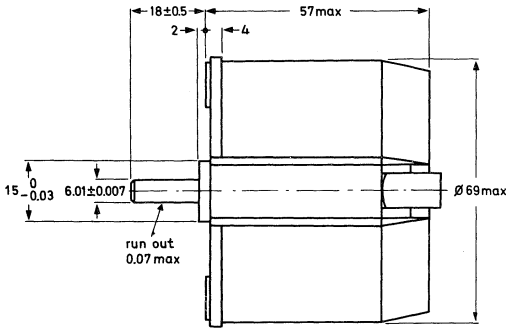

Coils in parallel

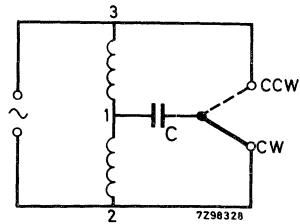

Coils in series

Connection diagrams

HIGH TORQUE, SLENDER TYPE

TECHNICAL DATA

		catalogue number 9904 111 06...					
		011	111	211	311	411	511
plain version		011	111	211	311	411	511
version with pinion		031	131	231	331	431	531
Nominal voltage	(V)	220	220	117	110	48	24
Frequency	(Hz)	60	50	60	50	50	50
Speed	(rev/min)	300	250	300	250	250	250
Current	(mA)	24	27	60	50	110	200
Input power	(W)	5	5	6	5	5	5
Starting torque	(gcm)	300	300	300	300	250	300
Working torque	(gcm)	375	375	375	375	350	375
Torque derating	(%)	0.25	0.25	0.25	0.25	0.25	0.25
Temperature increase of the motor	(degC)	35	35	45	35	35	35
Ambient temperature range	(°C)	-20 to +70					
Permissible voltage fluctuations	(%)	-10 to +10					
Insulation according to CEE10		class 2					
Insulation test voltage	(V)	2500					
Bearings		slide bearings					
Maximum radial force	(g)	1500					
Maximum axial force	(g)	150					
Housing		aluminium					
Weight	(g)	300					
Required phasing capacitor	(µF)	0.15	0.18	0.68	0.68	3.5	14
Permissible a. c. voltage	(V)	330	330	250	250	160	160
Catalogue number							
2222							
		277 71154	277 71184 ¹⁾	341 59684 ¹⁾	341 59684 ¹⁾	325 50355 ¹⁾	325 50146 ¹⁾

¹⁾ Readily available.

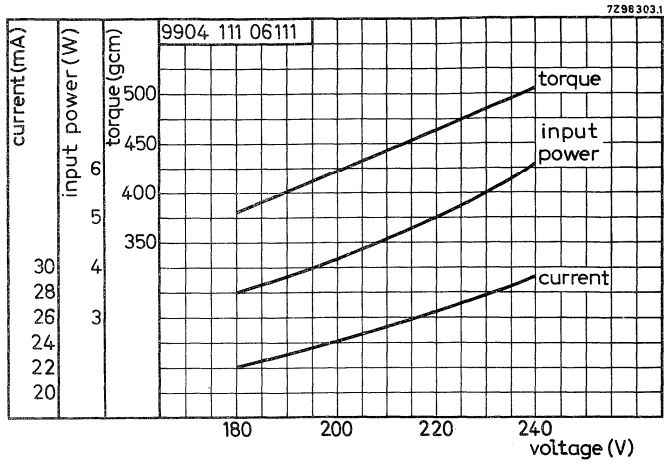

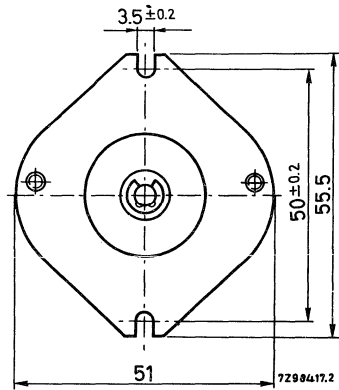
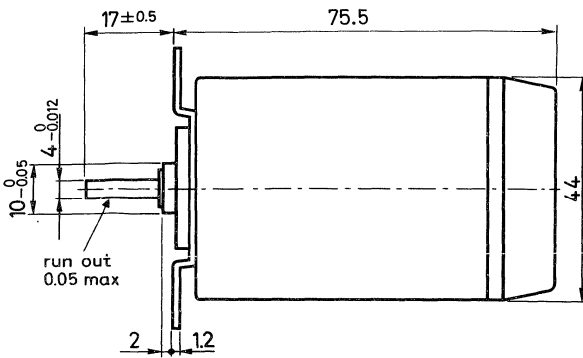

plain version

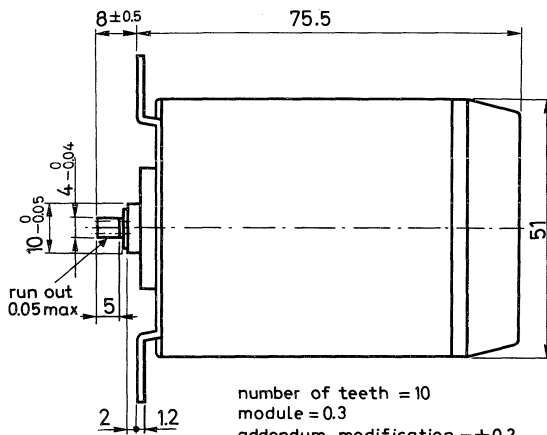

number of teeth = 10
 module = 0.3
 addendum modification = +0.2

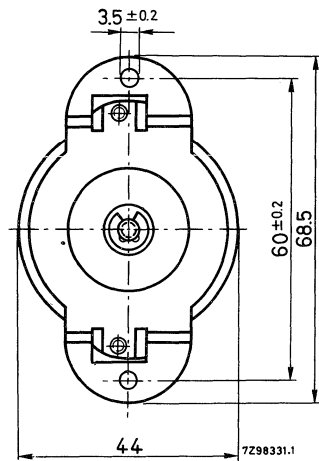

version with pinion

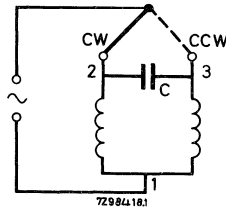

Connection diagram

SMALL TYPE

TECHNICAL DATA

		catalogue number 9904 111 07...									
		coils in parallel					coils in series				
plain version		311	411	511	611	711	311	411	511	611	711
version with pinion		331	431	531	631	731	331	431	531	631	731
Nominal voltage	(V)	110/117	48	24	12	6	220	110/117	48	24	12
Frequency	(Hz)	50/60									
Speed	(rev/min)	250/300									
Current	(mA)	4.5	8	18	55	90	5.5	12	18	55	90
Input power	(W)	0.5	0.4	0.45	0.6	0.55	1.3	1.2	0.9	1.3	1.1
Starting torque	(gcm)	25					45				
Working torque	(gcm)	25					45				
Torque derating	(%)	0.25					0.25				
Temperature increase of the motor	(degC)	10					25				
Ambient temperature range	(°C)	-20 to +70									
Permissible voltage fluctuations	(%)	-15 to +10									
Insulation according to CEE10		class 1									
Insulation test voltage	(V)	2500									
Bearings		slide bearings									
Maximum radial force	(g)	250									
Maximum axial force	(g)	75									
Housing		zinc plated									
Weight	(g)	75									
Required phasing capacitor	(µF)	0.047	0.22	1	5.6	20	0.18	0.68	2	14	40
Permissible a. c. voltage	(V)	250	160	160	63	160	160	160	160	160	160
Catalogue number 2222		341 59473	341 89224	341 89105	341 29565	325 50206	341 89184 1)	341 89684 1)	341 89205 1)	325 50146 1)	325 50206 (2x)

1) Readily available.

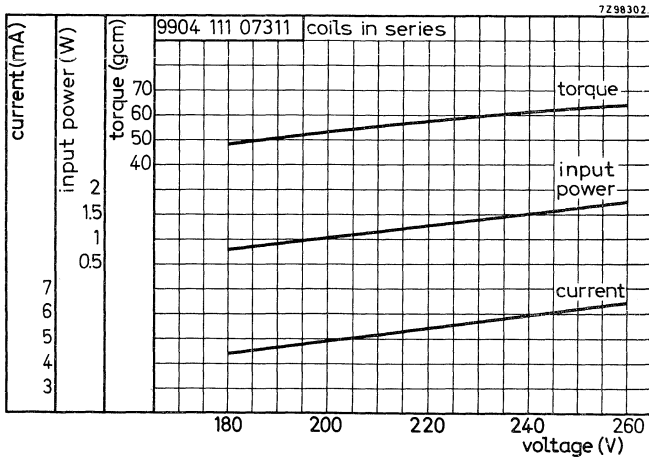
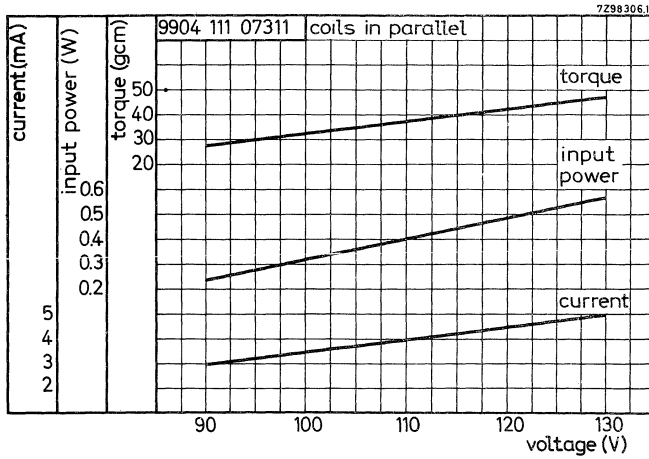

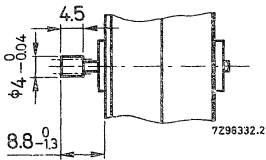
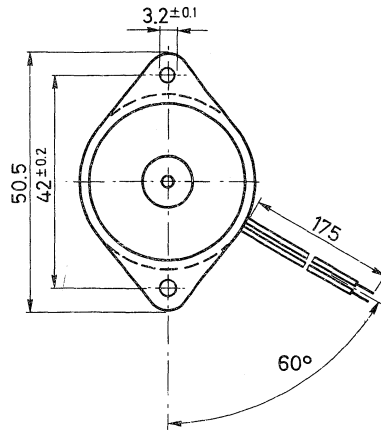
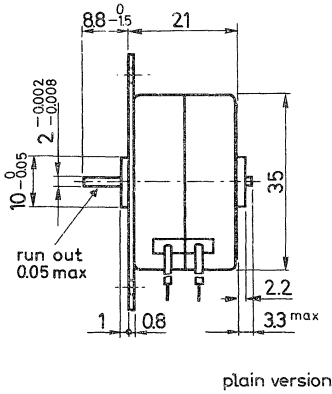

version with pinion

number of teeth = 10
 module = 0.3
 addendum modification = +0.2

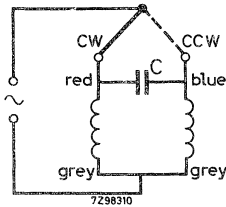

Coils in parallel

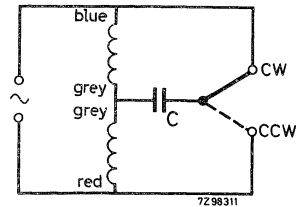

Coils in series

Connection diagrams

SYNCHRODRIVERS

DESCRIPTION

Fundamentally the synchrodriver is based upon the same principles as the unidirectional motors.

Due to the integration of motor and geartrain not sufficient space was left for a proper arrangement of the main and auxiliary poles. As a result the magnetic field was disturbed and therefore the maximum properties of our synchronous motors could not be achieved.

By a special magnetization of the rotor and the use of a one-way ratchet this disadvantage could be eliminated and our synchrodrivers are in all respects comparable to conventional motor-gear units.

Furthermore, plastic components fabricated according to the latest views are incorporated to make a reliable, attractively shaped product meeting mass-production requirements. These are all reasons why the synchrodriver represents the most economical solution for a wide range of timing devices as used in household appliances.

The basic version is an 8 rev/min synchrodriver; the starting time of this version is less than 1 s and the rebound angle smaller than 5 degrees. A version which has a speed of 1 rev/min is also available. It has been designed mainly for use in high temperatures (up to 120 °C intermittently).

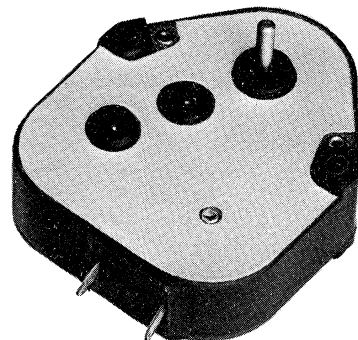

RZ 24634-5

MOUNTING

The synchrodrivers must be mounted by means of two non-ferrous screws or rivets. For the electrical connections use can be made of AMP terminals 160315.

TECHNICAL DATA

		catalogue number 9904 115					
		versions with a speed of 8 rev/min			versions with a speed of 1 rev/min		
		01061 01071	02061 02071	04061 04071	03002 ¹⁾ 03012 ¹⁾	05002 05012	07002 07012
clockwise rotation							
counterclockwise rotation							
Nominal voltage	(V)	220	110	117	220	117	110
Frequency	(Hz)	50	50	60	50	60	50
Speed	(rev/min)	8	8	9.6	1	1.2	1
Current	(mA)	14	26	35	14	35	26
Input power	(W)	2	2	2.5	2	2.5	2
Working torque 2)	(gcm)	400	400	380	1500 ³⁾	1500 ³⁾	1500 ³⁾
Torque derating	(%)	0.2	0.2	0.2	0.2	0.2	0.2
Temperature increase of the synchrodriver	(degC)	50	50	60	50	60	50
Ambient temperature range	(°C)	-5 to +50	-5 to +50	-5 to +40	-5 to +50 ³⁾	-5 to +50 ³⁾	-5 to +50 ³⁾
Permissible voltage fluctuations	(%)	-15 to +10					
Insulation according to CEE10		class 1					
Insulation test voltage	(V)	2500					
Bearings		slide bearings					
Maximum radial force	(g)	1000		1000 ³⁾			
Housing		zinc plated with nylon glass walls					
Weight	(g)	85					

1) Available with a spindle diameter of 3 mm under catalogue numbers 9904 115 03001 (cw) and 9904 115 03011 (ccw).

2) Torque at nominal voltage.

3) It is allowed to use this synchrodriver intermittently in the temperature range +50 to +120 °C (+50 to +100 °C for the synchrodrivers 9904 115 05002 and 9904 115 05012). As a result the maximum permissible torque and the maximum radial force decrease; at 120 °C the maximum permissible torque is 300 gcm, the maximum radial force is 100 g.

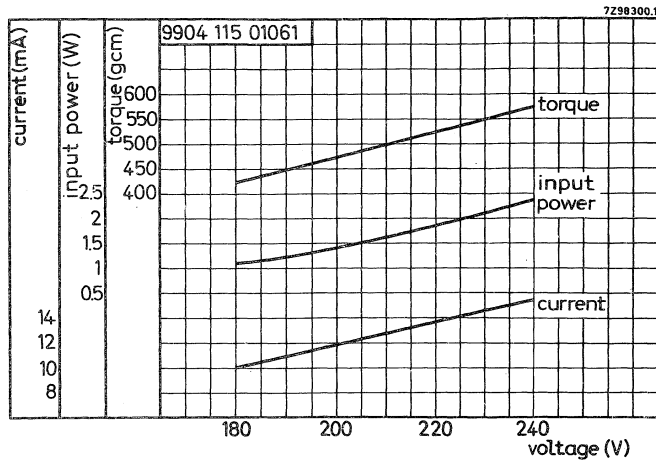

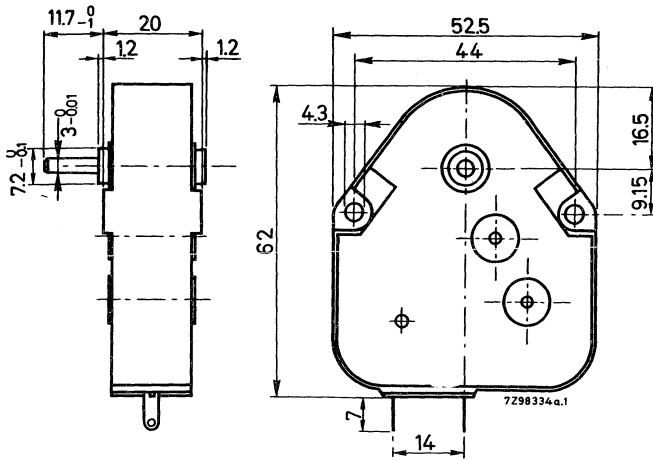

counterclockwise rotation

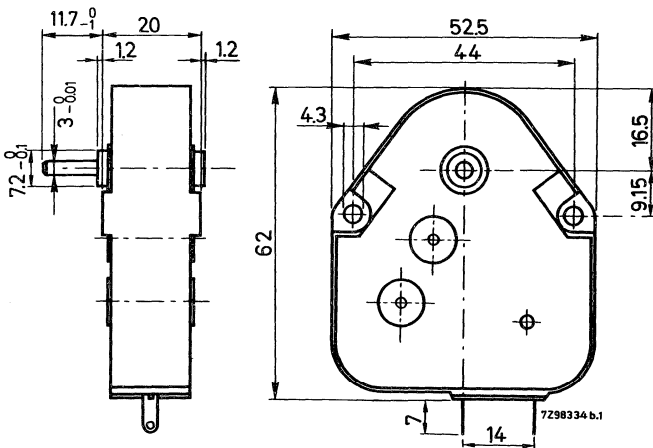

clockwise rotation

Versions with a speed of 8 rev/min (spindle diameter 3 mm).

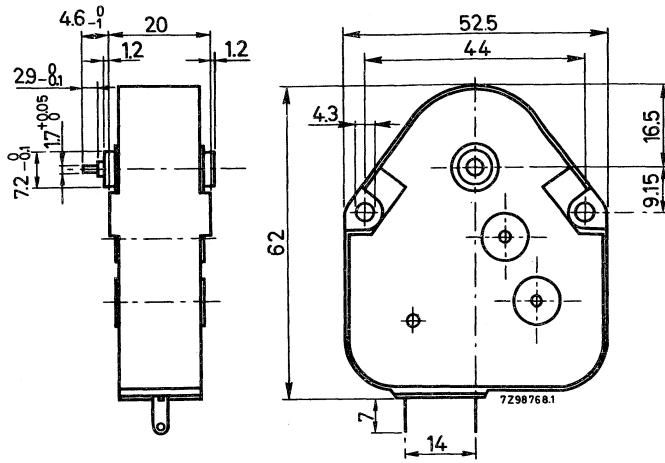

counterclockwise rotation

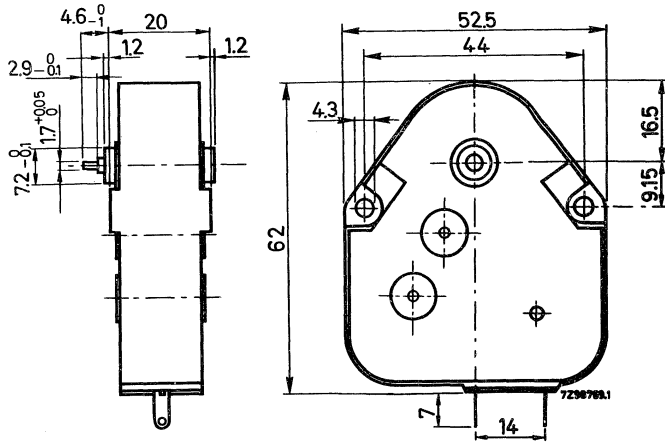

clockwise rotation

Versions with a speed of 1 rev/min (spindle diameter 1.7 mm).

A.C./D.C. SYNCHRONOUS MOTORS

RZ 52801-28

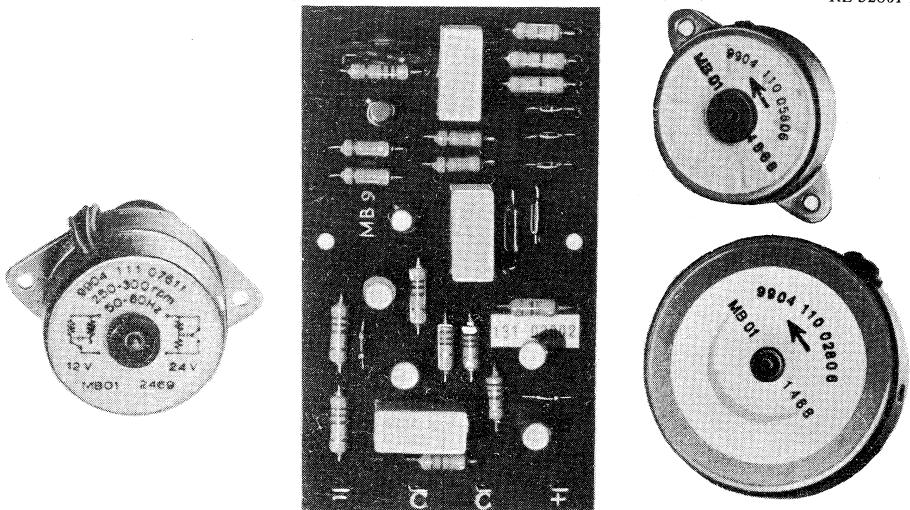

APPLICATION

These synchronous motors, in conjunction with a d. c. to a. c. inverter, are used for applications which require:

- instantaneous automatic switchover to a d. c. standby supply in the event of an a. c. mains failure
- a choice of supply, such as portable and transportable electrical measuring instruments
- a d. c. supply only, such as portable record players and tape recorders.

DESCRIPTION

These synchronous motors are conventional 12 V unidirectional or reversible motors, the former employing slightly modified coils. The motors operate either directly from a 12 V a. c. supply, or indirectly (via an inverter which is mounted on a printed-wiring board) from a 12 V d. c. supply. The supply used is fed either directly to the motor (a. c.) or to the inverter (d. c.) via a switching element.

TECHNICAL DATA

	catalogue number					
	unidirectional motors			reversible motors		
clockwise rotation	9904 110 02806	9904 110 05806	9904 111 04611	9904 111 07611		
counterclockwise rotation	9904 110 02808	9904 110 05808				
Catalogue number of associated inverter	9904 131 03001	9904 131 03001	9904 131 03002	9904 131 03002		
Type of supply	a. c.	d. c.	a. c.	d. c.	a. c.	d. c.
Nominal voltage (V)	12	12	12	12	12	12
Frequency (Hz)	50	50 ^{*)}	50	50 ^{*)}	50	50 ^{*)}
Speed (rev/min)	250	250	250	250	250	250
Working torque (gcm)	30	20	7	6	110	60
Ambient temperature range (°C)	-5 to +50	-5 to +50	-5 to +50	-5 to +50	-5 to +50	-5 to +50
Bearings	slide	slide	slide	slide	slide	slide
Maximum radial force (g)	90	90	30	30	500	500
Maximum axial force (g)	50	50	10	10	150	150
Required phasing capacitor (µF)	-	-	-	-	12	12
Catalogue number	-	-	-	-	2222 325 50126	2222 341 29475

*) Produced by associated inverter.

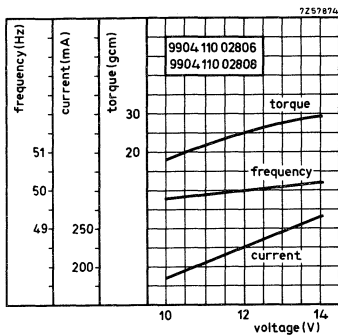

Using d. c. supply and inverter

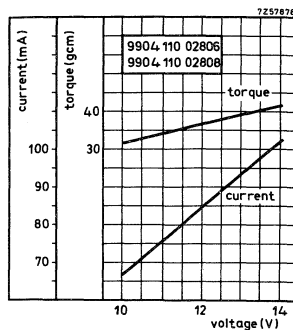

Using a. c. supply at 50 Hz

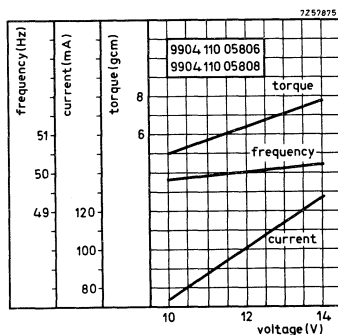

Using d. c. supply and inverter

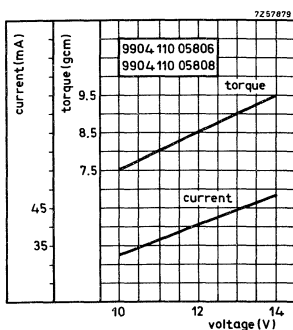

Using a. c. supply at 50 Hz

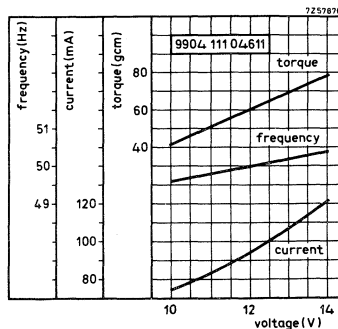

Using d. c. supply and inverter

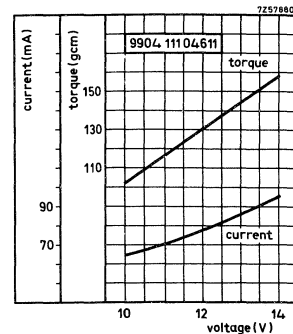

Using a. c. supply at 50 Hz

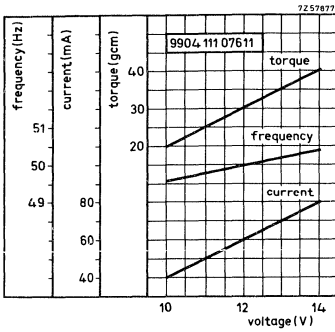

Using d. c. supply and inverter

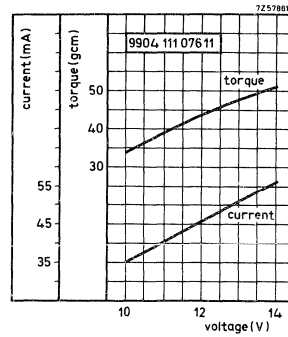

Using a. c. supply at 50 Hz

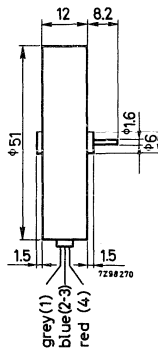

Unidirectional motor 9904 110 02806
 or 9904 110 02808

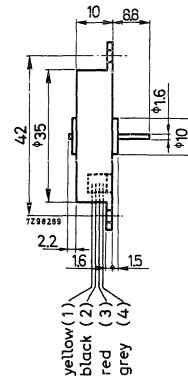

Unidirectional motor 9904 110 05806
 or 9904 110 05808

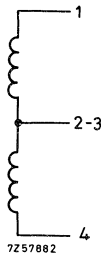

Connection diagram

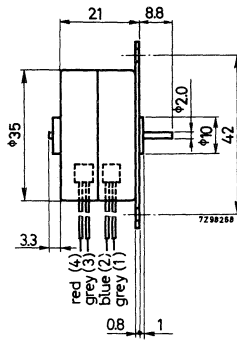

Reversible motor 9904 111 07611

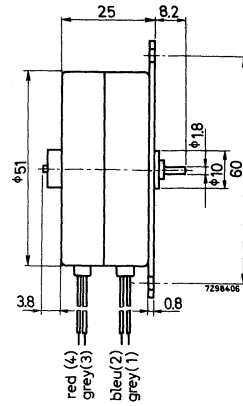

Reversible motor 9904 111 04611

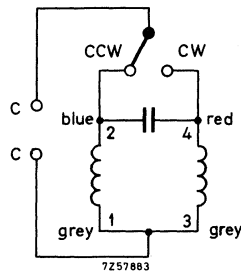

Connection diagram

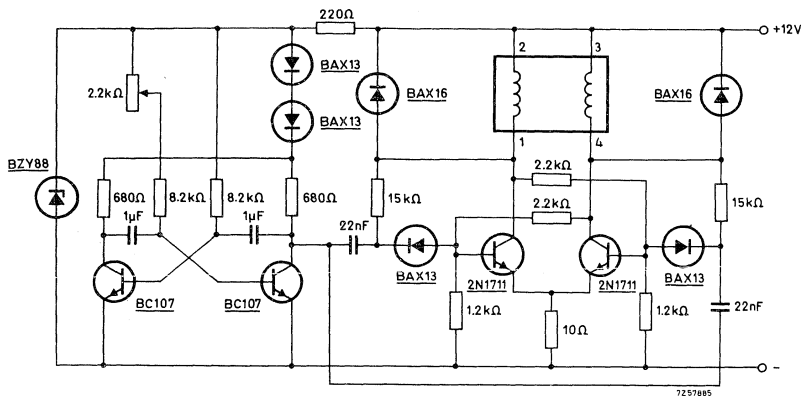

Circuit diagram of inverter 9904 131 03001, for use in conjunction with unidirectional motors.

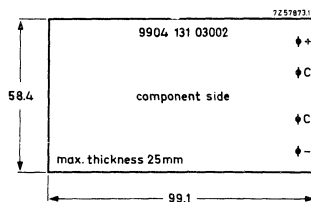
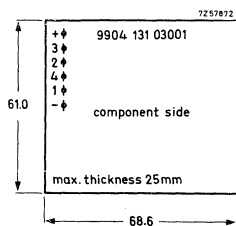

Printed-wiring board connections.

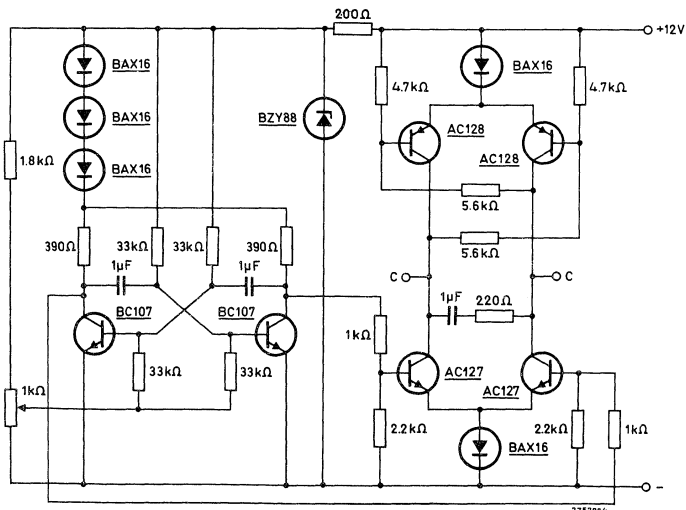

Circuit diagram of inverter 9904 131 03002, for use in conjunction with reversible motors.

UNIVERSAL PROGRAMME SWITCH ASSEMBLY KIT

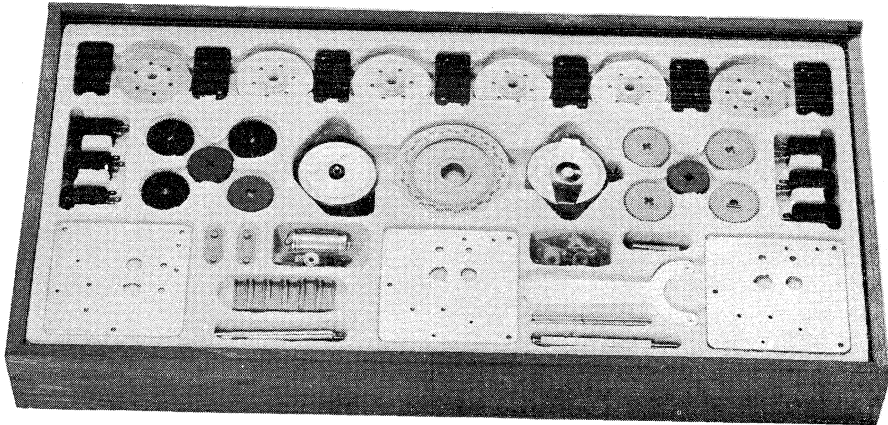
RZ 24634-8

INTRODUCTION

This assembly kit enables the user to construct, with a limited number of components, a programme switch for many different timing cycles, very simple in design but sturdy enough to be suitable for both professional and non-professional purposes. In the professional field the programme switch can be valuable in the programming of industrial processes or scientific research experiments. As non-professional applications we may mention the use in domestic appliances or entertainment apparatus, for instance

- electric blankets
- electric water boilers
- electric heaters
- illumination-control units for shop windows.

The timing function is carried out by a camshaft, and the number of revolutions this makes per minute is dependent on the selected gearing-down ratio.

Two types of kit are available:

- for use with 220 V, 50 Hz supply, catalogue number 9904 131 02001
- for use with 117 V, 60 Hz supply, catalogue number 9904 131 02002.

SHORT DESCRIPTION

The universal programme switch consists of four basic elements:

1. The motor.

Unidirectional motor for 220 V, 50 Hz (catalogue number 9904 110 02124) or for 117 V, 60 Hz (catalogue number 9904 110 02223), or reversible motor for 220 V, 50 Hz (catalogue number 9904 110 04134) or for 117 V, 60 Hz (catalogue number 9904 111 04332).

For details see "Technical Data" of motors 9904 110 02... and 9904 111 04... respectively.

2. The reduction gear.

A wide variety of pinions and gearwheels makes it possible to obtain a great number of gear ratios, and thus outgoing-spindle speeds between 1 rev/min and 1 rev/24h.

3. The camshaft with cams.

The camshaft carries up to 6 adjustable cams.

Each cam consists of two separate discs, which can be turned in respect to each other in order to obtain the desired switching time.

This adjustment can be made with a special tool on which the angle of adjustment is indicated.

4. The switch assembly, comprising 6 microswitches with alternating contacts together with insulator plates, operating levers and rollers.

A comprehensive instruction manual is supplied with each kit to explain the assembly procedure and the adjustment of the various cams and contacts.

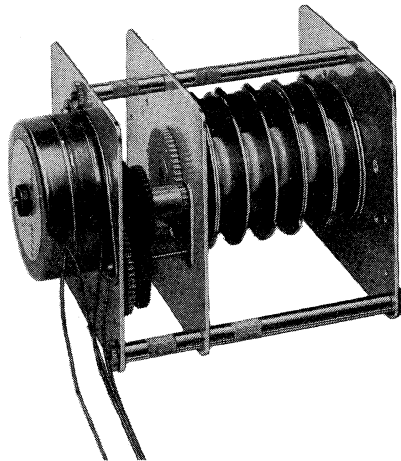

Assembled programme switch

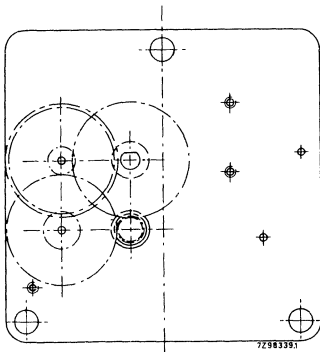
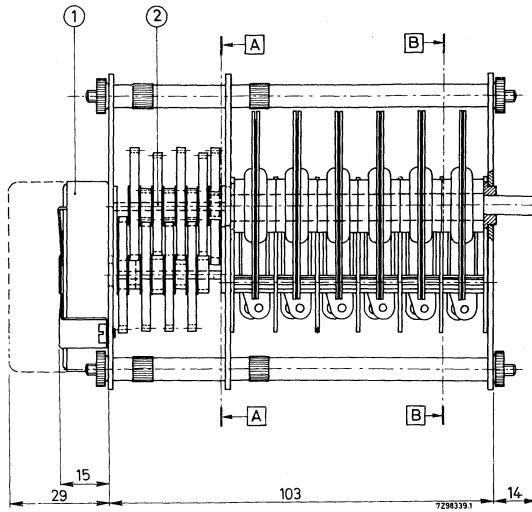

A-A

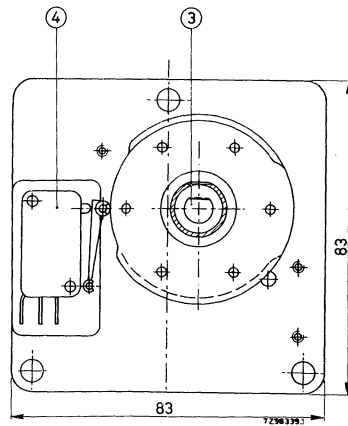

B-B

GEARBOXES

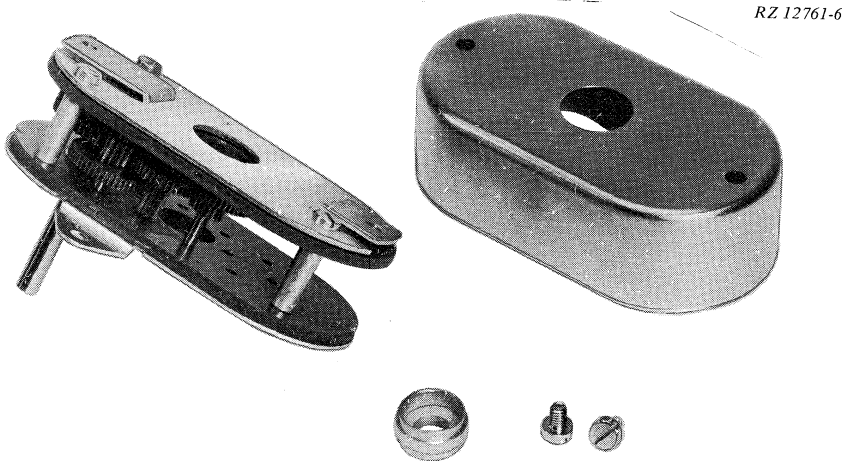

GENERAL

The reduction gearboxes of the 9904 130 01... series have been designed for use with the synchronous motors provided with standard pinions. They are supplied separately but can easily be mounted to any of these motors.

To attach the motor to the gearbox, place the reversible centring bush in position so that it fits the centring rim on the motor casing, and fasten the motor by means of the two screws in the gearbox cover. For fastening the motors 9904 110 05... and 9904 111 07... the gearbox is provided with two threaded holes M2.6.

Many different gear ratios can be built into the same metal casing. There are over 60 standard gear ratios, 31 are preferred ones.

The gearboxes are meant for small series and professional applications with versatility as the main property. As a rule small quantities of those in the preferred range can be supplied from stock.

For all data necessary for selecting the appropriate gearbox from the series, see the survey at the end of this section.

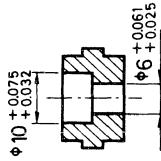
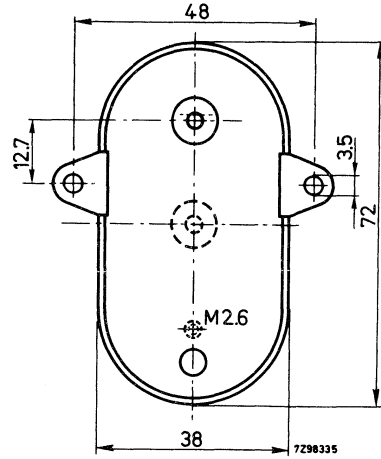
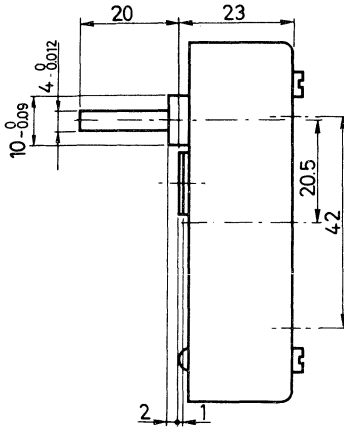

centring bush

TECHNICAL DATA

Maximum permissible load	2000 gcm
Maximum permissible radial force	1000 g
Maximum permissible axial force	200 g

Gearbox-performance graph

By using a gearbox with a large gearing-down ratio it will be possible to obtain a torque at the outgoing spindle of the gearbox which surpasses the maximum permissible load on the gearbox of 2000 gcm. The gearbox-performance graph therefore shows 2000 gcm as the torque limit.

The graph can be used either for finding the maximum obtainable torque value of a given motor + gearbox, or the proper motor-gearbox combination for obtaining a given torque.

- a. Motor 9904 110 05...; required gearing-down ratio 36 : 1.
The graph shows the maximum obtainable torque to be 100 gcm. Gearbox efficiency has been taken into account.
- b. Desired torque value 100 gcm, required gearing-down ratio 36 : 1.
The graph shows that the motor with the catalogue number 9904 110 05... does the job.

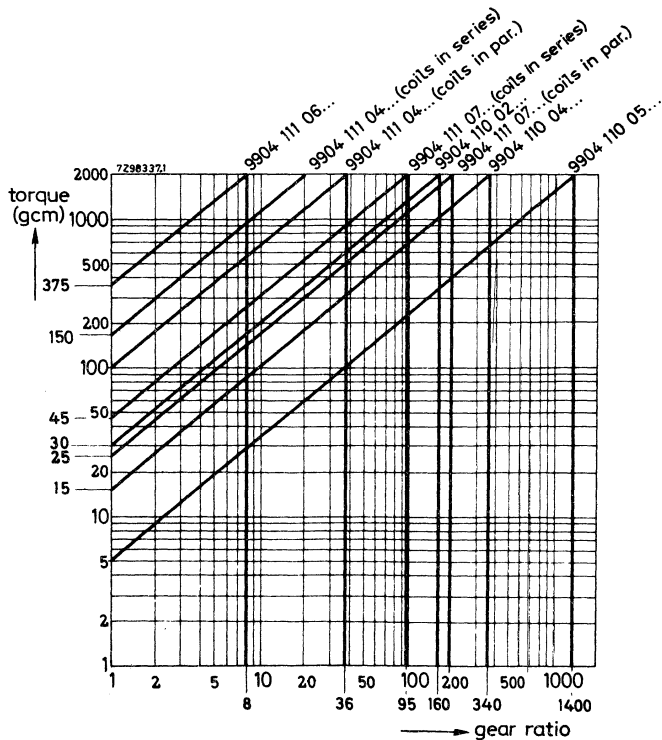

SURVEY

Preferred range

catalogue number	gear ratio	number of revolutions of outgoing spindle when coupled to a motor operating from		direction of rotation of outgoing spindle compared to motor spindle 1)	efficiency
		50 Hz mains	60 Hz mains		
9904 130 01001	25:6	60 rev/min	72 rev/min	same	0.64
01003	25:4	40 rev/min	48 rev/min	same	0.64
01004	25:3	30 rev/min	36 rev/min	same	0.64
01005	10:1	25 rev/min	30 rev/min	same	0.64
01006	25:2	20 rev/min	24 rev/min	same	0.64
01008	50:3	15 rev/min	18 rev/min	opposite	0.51
01009	20:1	12.5 rev/min	15 rev/min	same	0.64
01011	25:1	10 rev/min	12 rev/min	opposite	0.51
01014	100:3	7.5 rev/min	9 rev/min	opposite	0.51
01016	125:3	6 rev/min	7.2 rev/min	opposite	0.51
01017	50:1	5 rev/min	6 rev/min	opposite	0.51
01019	125:2	4 rev/min	4.8 rev/min	opposite	0.51
01021	250:3	3 rev/min	3.6 rev/min	same	0.41
01087	75:1	3 $\frac{1}{3}$ rev/min	4 rev/min	opposite	0.51
01023	125:1	2 rev/min	2.4 rev/min	opposite	0.51
01026	200:1	1.25 rev/min	1.5 rev/min	same	0.41
01027	250:1	1 rev/min	1.2 rev/min	same	0.41
01028	300:1	50 rev/h	1 rev/min	same	0.41
01034	500:1	30 rev/h	36 rev/h	same	0.41
01037	750:1	20 rev/h	24 rev/h	opposite	0.33
01038	2500:3	18 rev/h	21.6 rev/h	opposite	0.33
01039	1000:1	15 rev/h	18 rev/h	opposite	0.33
01041	1250:1	12 rev/h	14.4 rev/h	opposite	0.33
01042	1500:1	10 rev/h	12 rev/h	opposite	0.33
01051	3750:1	4 rev/h	4.8 rev/h	same	0.26
01054	5000:1	3 rev/h	3.6 rev/h	same	0.26
01055	6000:1	2.5 rev/h	3 rev/h	same	0.21
01062	15 000:1	1 rev/h	1.2 rev/h	opposite	0.21
01071	45 000:1	8 rev/24h	9.6 rev/24h	same	0.17
01077	90 000:1	4 rev/24h	4.8 rev/24h	same	0.17
01085	360 000:1	1 rev/24h	1.2 rev/24h	opposite	0.14

1) When the direction of rotation of the outgoing spindle is not the one which is desired a motor with the reverse direction of rotation should be chosen (e.g. 9904 110 02131 instead of 9904 110 02121).

Non-preferred range

catalogue number	gear ratio	number of revolutions of outgoing spindle when coupled to a motor operating from		direction of rotation of outgoing spindle compared to motor spindle ¹⁾	efficiency
		50 Hz mains	60 Hz mains		
9904 130 01022	100:1	2.5 rev/min	3 rev/min	opposite	0.51
01025	500:3	1.5 rev/min	1.8 rev/min	same	0.41
01088	3000:9	45 rev/h	54 rev/h	opposite	0.33
01031	375:1	40 rev/h	48 rev/h	same	0.41
01032	400:1	37.5 rev/h	45 rev/h	opposite	0.33
01033	1250:3	36 rev/h	43.2 rev/h	opposite	0.33
01035	600:1	25 rev/h	30 rev/h	opposite	0.33
01036	625:1	24 rev/h	28.8 rev/h	same	0.41
01043	5000:3	9 rev/h	10.8 rev/h	same	0.26
01044	1875:1	8 rev/h	9.6 rev/h	opposite	0.33
01045	2000:1	7.5 rev/h	9 rev/h	opposite	0.33
01047	2500:1	6 rev/h	7.2 rev/h	opposite	0.33
01048	3000:1	5 rev/h	6 rev/h	same	0.26
01049	3125:1	4.8 rev/h	5.76 rev/h	opposite	0.33
01056	6250:1	2.4 rev/h	2.88 rev/h	opposite	0.21
01057	7500:1	2 rev/h	2.4 rev/h	opposite	0.21
01059	10 000:1	1.5 rev/h	1.8 rev/h	opposite	0.21
01061	12 500:1	1.2 rev/h	1.44 rev/h	opposite	0.21
01064	20 000:1	0.75 rev/h	0.9 rev/h	opposite	0.21
01066	24 000:1	15 rev/24h	18 rev/24h	same	0.17
01068	30 000:1	12 rev/24h	14.4 rev/24h	same	0.17
01069	36 000:1	10 rev/24h	12 rev/24h	same	0.17
01093	40 000:1	9 rev/24h	10.8 rev/24h	same	0.17
01072	48 000:1	7.5 rev/24h	9 rev/24h	same	0.17
01074	60 000:1	6 rev/24h	7.2 rev/24h	same	0.17
01075	72 000:1	5 rev/24h	6 rev/24h	same	0.17
01076	75 000:1	4.8 rev/24h	5.76 rev/24h	same	0.17
01079	120 000:1	3 rev/24h	3.6 rev/24h	same	0.17
01082	180 000:1	2 rev/24h	2.4 rev/24h	opposite	0.14
01083	240 000:1	1.5 rev/24h	1.8 rev/24h	opposite	0.14
01084	300 000:1	1.2 rev/24h	1.44 rev/24h	opposite	0.14

¹⁾ When the direction of rotation of the outgoing spindle is not the one which is desired a motor with the reverse direction of rotation should be chosen (e. g. 9904 110 02131 instead of 9904 110 02121).

Stepper motors



General	page B3
Industrial digital motors	page B15
Professional digital and servo-mount digital motors	page B35
4- and 8-phase electronic switch	page B83

INTRODUCTION

Stepper motors are rapidly becoming recognized as the best - and often unique - solution to many control problems. This is due to their lacking the disadvantages of closed-loop servo-mechanism systems; extreme sensitivity for interference, and the need for the input information to be converted from digital to analogue. Besides stepper motors afford a cheaper solution. Two kinds of stepper motors exist: the variable reluctance and the permanent magnet type. Our motors are of the latter construction which is distinguished from the variable reluctance type by its simplicity, very small size, large step angle and better damping (giving relative freedom from the effects of resonance and a smaller overshoot). Especially the adoption of the 8-phase construction led to the present satisfactory situation.

Our line of permanent magnet stepper motors covers working torques from 60 gcm to 1600 gcm, pull-out rates from 320 steps/s (400 rev/min) to 16 000 steps/s (10 000 rev/min) and pull-in rates from 140 steps/s (350 rev/min) to 1200 steps/s (750 rev/min).

General design of the motor has been optimised over the long period we have been concerned with stepper motor production. All motors can be delivered complete with their own electronic control, thus ensuring that the motors always deliver the high performance of which they are capable. Roller or ball bearings are standard on most models*, and the PD and SMD types can be made to satisfy MIL specifications on request.

The range consists of 21 motors, eight of which are PD ("Professional Digital") types, a further eight SMD ("Servo-Mount Digital") types, and five ID ("Industrial Digital") types. A PD motor and its corresponding SMD type, which has the PD type number + 1, have identical specifications except for the mounting. PD types have a square mounting flange, and the SMD types have the standard servo-motor mounting. ID types may be used in less-demanding applications.

* Except types ID07, ID04 and ID06, which are fitted with sleeve bearings.

PRINCIPLES

Fig. 1 illustrates the action diagrammatically. The motor shown is a 4-phase, 2-pole type; this means that the stator has four phases and the rotor two poles (one north and one south). With phase P and phase R energized, the four stator poles take the polarities shown in Fig. 1a and the rotor turns to the position 1. If phase Q is now energized instead of phase P, the rotor will turn through 90° (anti-clockwise) to the position 2 shown in Fig. 1b. Steps to the positions 3 and 4 can be obtained in a similar fashion. Fig. 1c shows the effect of completely de-energizing stator RS; the rotor turns a half step to intermediate position $2\frac{1}{2}$. If stator PQ had been completely de-energized, the rotor would have turned anti-clockwise to intermediate position $1\frac{1}{2}$.

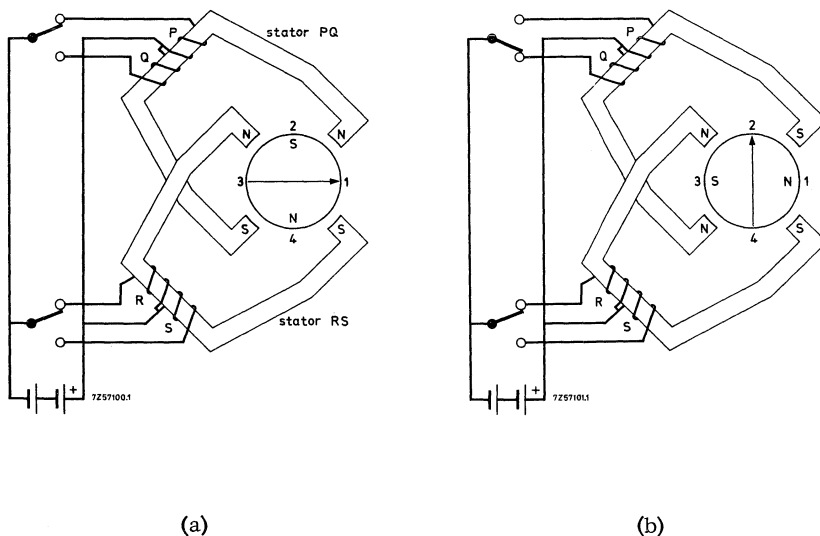
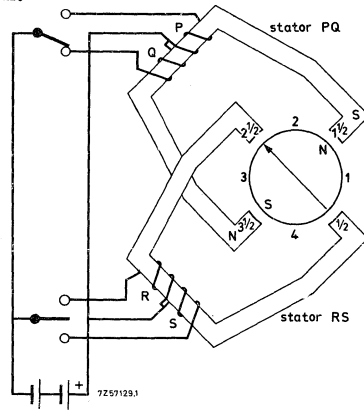

Fig. 1. Diagrammatic representation of a 4-phase, 2-pole motor:
 (a) rotor at position 1;
 (b) rotor at position 2;
 (c) rotor at intermediate position $2\frac{1}{2}$ (see next page).

Energization of phases related to rotor position.

Phases energized	Stator de-energized	Resultant rotor step position
P, R	-	1
R	PQ	$1\frac{1}{2}$
R, Q	-	2
Q	RS	$2\frac{1}{2}$
Q, S	-	3
S	PQ	$3\frac{1}{2}$
S, P	-	4
P	RS	$\frac{1}{2}$

The direction of rotation can be reversed at any point.



(c)

If we now make a stator with eight phases and place in it the 2-pole rotor as shown in Fig. 2, the rotor will turn only 45° per step. An important advantage of the 8-phase stator is that during the switching from one phase to its partner (i.e. when complete de-energization of a whole stator occurs), 75% of the full torque is still available because three out of the four stators remain energized. In Fig. 2 complete de-energization of stator PQ (phases R, T, V still energized) will cause the rotor to turn to intermediate position $1\frac{1}{2}$; complete de-energization of winding VW (phases P, R, T still energized), will cause the rotor to turn to intermediate position $\frac{1}{2}$.

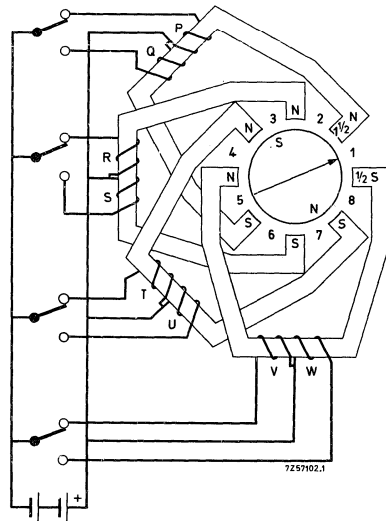

Fig. 2. Diagrammatic representation of an 8-phase, 2-pole motor: rotor at position 1.

Thus, an advantage of 8-phase motors is that the stepping angle can be small while still having a high torque and stepping rate. In general, the smaller the stepping angle, the greater the resolution. The small stepping angle of our motors (7.5° for 4-phase, 3.75° for 8-phase) has been achieved by using a 24 pole rotor and stator.* Although not often used, it is possible to halve these stepping angles by counting the intermediate steps; as noted above, however, the torque is then reduced. To obtain the maximum torque for a certain average power dissipation, the current in each phase should reach its maximum value immediately and maintain this, and the switch-over time from one phase to the next should be zero. The only way in which this second requirement can be closely approached is to use electronic switching. Two inexpensive electronic switching circuits using integrated circuits on printed-wiring boards have been developed for our motors, one for 4-phase and the other for 8-phase types. The first requirement—that the current in each phase should reach its maximum value immediately and maintain this—can usually be satisfactorily approximated at start and low stepping rates simply by paralleling each winding with a capacitor (C_V in Fig.3) and using a higher supply voltage via a resistor R_V . During the time that a phase is switched off, C_V charges via R_V to voltage V_D ; when the switch is again closed, C_V discharges through the winding. Resistor R_V serves in addition another purpose: at higher frequencies it reduces the opposing currents in the phases due to the back e.m.f. thus increasing pull-in and pull-out rates, and torque. This method increases the power consumption of the system, due to the dissipation of resistor R_V . If dissipation in the system is to be kept to a minimum, it might be better to choose a motor that can attain the speed without the help of the RC-network.

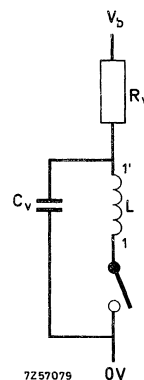

Fig. 3. Connection of the compensating network R_V - C_V . (L is the stator phase winding 1; the numbers 1 and 1' refer to the leads to and from phase 1. The switch can be a transistor, as in the electronic switches, described below).

* Except types ID08, PD22, SMD23, PD24 and SMD25, which have a 12 pole construction (15° and 7.5° step angles).

TERMINOLOGY

(in alphabetical order)

Detent Torque: The maximum torque that can be applied to the spindle of an unexcited motor without causing continuous rotation. Unit: gcm.

Deviation: The change in spindle position from the unloaded holding position when a certain torque is applied to the spindle of an excited motor. Unit: degrees.

Holding Torque: The maximum steady torque that can be externally applied to the spindle of an excited motor without causing continuous rotation. Unit: gcm.

Maximum Pull-In Rate (Speed): The maximum switching rate (speed) at which an unloaded motor can start without losing steps. Unit: steps/s (rev/min).

Maximum Pull-Out Rate (Speed): The maximum switching rate (speed) which the unloaded motor can follow without losing steps. Unit: steps/s (rev/min).

Overshoot: The maximum amplitude of the oscillation around the final holding position of the rotor after cessation of the switching pulses. Unit: degrees.

Permanent Overshoot: The number of steps the rotor moves after cessation of the switching pulses. Unit: steps.

Phase: Each winding connected across supply voltage.

Pull-In Rate (Speed): The maximum switching rate (speed) at which a frictionally loaded motor can start without losing steps. Unit: steps/s (rev/min).

Pull-In Torque: The maximum torque that can be applied to a motor spindle when starting at the pull-in rate. Unit: gcm.

Pull-Out Rate (Speed): The maximum switching rate (speed) which a frictionally loaded motor can follow without losing steps. Unit: steps/s (rev/min).

Pull-Out Torque: The maximum torque that can be applied to a motor spindle when running at the pull-out rate. Unit: gcm.

Start Range: The range of switching rates within which a motor can start without losing steps.

Step Angle: The nominal angle that the motor spindle must turn through between adjacent step positions. Unit: degrees.

Stepping Rate: The number of step positions passed by a fixed point on the rotor per second. Unit: steps/s.

Slew Range: The range of switching rates within which a motor can run unidirectionally and follow the switching rate (within a certain maximum acceleration) without losing steps, but cannot start, stop or reverse.

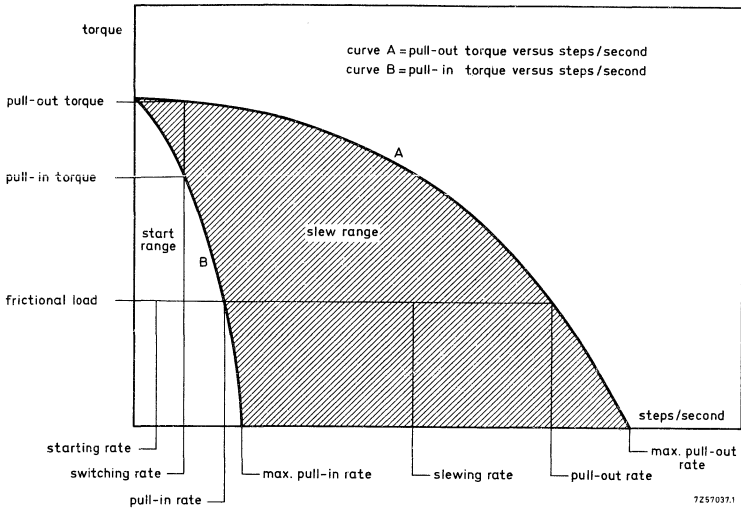

Typical stepper motor curves illustrating the terminology used.

CHARACTERISTICS

The characteristic of foremost importance to the designer is the way in which rotor torque varies with speed (stepping rate). Fig. 1 compares the torque/stepping rate characteristics of the PD20 and PD12, from which it is clear that motors are available to cope with most situations. These curves can be further modified so that peak torque occurs at other than zero stepping rate, by using certain values of resistors and capacitors across the windings (see relevant data sheets). In addition, the curves can be raised or lowered by varying the applied voltage.

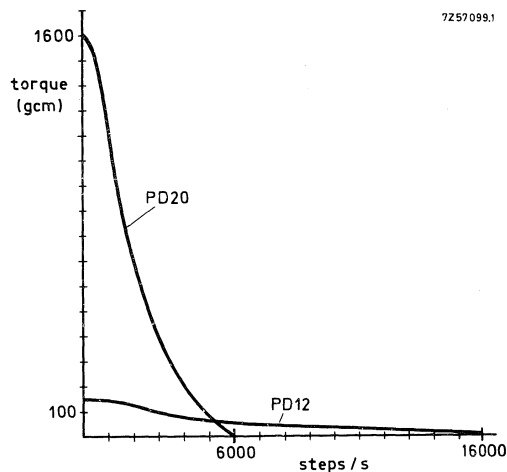

Fig. 1. Typical curves from two motors in the range: the PD20 (SMD21) and the PD12 (SMD13).

By way of example, take the torque/stepping rate characteristic of the PD24 (Fig. 1) and examine it in detail. The solid "pull-in torque" curve A is the start characteristic: from this can be read the allowable load friction torque which, when applied to the rotor spindle, will allow the rotor to reach a certain stepping rate from stand-still without missing a step. The "pull-out torque" curve B shows allowable friction torque plotted against stepping rate after gradual increase of the rate. The motor cannot be quickly accelerated or decelerated in this region (i.e. between the start curve and the slew curve) without the risk of discrepancies appearing between number of pulses supplied and number of steps moved by the rotor. This region is called the "slew range".

The two solid curves described above are for the values of R_V , C_V and V_b given. The two broken curves are for $V_b = 5\text{ V}$ and no C_V or R_V . (Curve a: pull-in torque; curve b: pull-out torque).

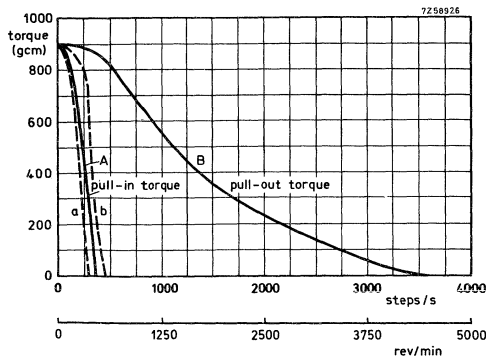

Fig. 2. Start and slew range curves for the PD24.

In practice, the stepper motor must be started at a stepping rate not exceeding the rate given by the start curve for the friction load present, then brought into the slew range by gradually increasing the pulse rate. To stop accurately, the pulse rate must first be gradually reduced, back to the rate used to start the motor. Below this rate, the rotor will stop without permanent overshoot even if the pulse rate is suddenly reduced to zero.

The curves given in the data section assume the inertia of the load to be small compared to the rotor inertia. If the load inertia is appreciable, the start curve will be adversely affected in that stepping rates will be reduced. The slew range will not be affected; however, acceleration and deceleration in the slew range must then be smaller.

Stepper motors are inherently prone to instability due to the pulsating nature of the energizing signals. Often, the instability region lies outside the working region, or is very slight, thus causing no problem. If instability is a problem, however, there are a number of ways available to reduce it to insignificance. Instability results from the internal resonance of the "motor + electronics" system. The resonance frequency can be affected by the load inertia and the RC network, while the amplitude of oscillation is determined by the friction load and RC. It may also be possible to move the working speed range of the motor above or below the instability region.

Our motors do in fact exhibit instability over certain speed ranges for the values of R_V , C_V and V_D chosen to produce the curves given in the data sheets below, it must be remembered, however, that firstly the R_V - C_V - V_D values were chosen only with an eye to producing the best speed, and secondly, that the load inertia is assumed negligible. With appreciable inertia, the instability can disappear.

The dissipation stated for each motor in the PD and SMD series is that which gives a 40-45 degC rise in motor temperature. The maximum temperature for which the motors are designed is 125 °C. For the ID series, a temperature rise of 30-40 degC has been allowed: maximum temperature is 100 °C. If used at a low ambient temperature, a higher supply voltage is permissible giving correspondingly higher torque.

* For ambient temperatures of more than 25 °C, the torque will decrease by 0.2% per degC (approx). There is also a derating at low temperature.

APPLICATIONS

The stepper motor converts electrical digital information into mechanical movement. Given this property plus the fact that the digital technique is the predominant method used for information processing, applications for stepper motors cover an extremely wide field.

A very important advantage of stepper motors over most other electro-mechanical converters is that the control can be open-loop: the error is non-cumulative, and in many cases information feedback is not necessary. Elimination of feedback loops saves much expense, both in design and installation.

Stepper motors can be thought of as positioners, or as variable speed drives; below are a few examples.

As positioners:

- Pulse counters on production lines
- Selectors in information retrieval systems
- Remote indicators
- Numerically controlled machine tool drives
- Line spacing control for print-out machines
- Punched-tape drives
- Diaphragm control in optical and medical equipment.

As variable speed drives:

- Curve tracers
- Paper-feed devices in chart recorders
- Drives for electronic sweep generators
- Synchronizers between machines and their recording instruments
- Variable speed spool drives in the textile industry.

As will be seen from the data given below, our motors cover a wide range of performance. Motors used as positioners usually require high starting torque, such as given by the types PD18 and PD20. On the other hand, motors used as variable speed drives require high speed, provided by types PD12 and PD16. Applications in which both high torque and high speed are necessary are likely to be covered by types PD20 and PD24. The torque/speed (torque/stepping rate) graphs are in fact the first thing the designer is usually interested in when choosing the motor; typical curves for each motor are given in the relevant data sheet.

A stepper motor can also be used as an integrator. By feeding a continuously varying signal to an analogue-digital converter giving a pulse frequency proportional to the amplitude of the input signal, a stepper motor supplied with those pulses will move the load attached to its shaft through a distance proportional to the time integral of the signal.

STEPPER MOTOR

QUICK REFERENCE DATA	
Step angle	7° 30'
Maximum torque	150 gcm *)
Holding torque	225 gcm *)
Maximum pull-in rate	350 steps/s
Maximum pull-out rate	550 steps/s

RZ 26753-7

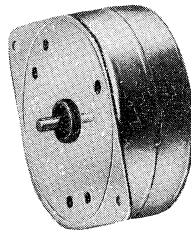

APPLICATION

This stepper motor has been designed for converting electrical digital information, supplied via an electronic switch, into mechanical movement. It can be used as a positioner or in a variable speed drive.

DESCRIPTION

The stepper motor has a 4-phase stator and a permanent magnet rotor with 24 poles in a rugged and simple construction. The motor coils are adapted to the electronic switch 9904 131 03003 (see relevant data sheet) for optimum performance.

*) 1 gcm = 10^{-4} Nm

TECHNICAL DATA

Dimensions (in mm) and connections

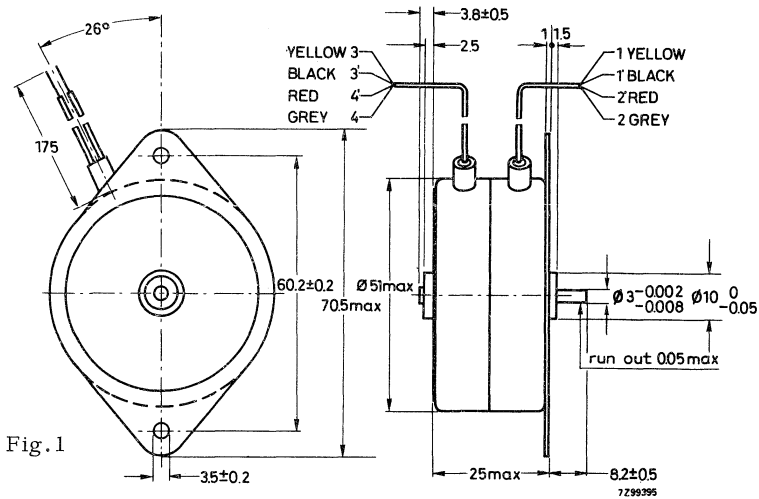

Fig. 1

Marking

The connecting leads are colour-coded, see Fig. 1.

Maximum pull-in torque	150 gcm
Holding torque	225 gcm
Maximum pull-in rate ¹⁾	350 steps/s
Maximum pull-out rate ¹⁾	550 steps/s
Number of steps per revolution	48
Step angle	7° 30'
Step angle tolerance	± 20' non cumulative
Direction of rotation	electrically reversible
Mass moment of inertia of the rotor	11 gcm ²
Maximum axial force	150 g
Maximum radial force	500 g
Bearings	sleeve
Weight	160 g
Ambient temperature range	
operating	-20 to +70 °C
storage	-40 to +85 °C
Maximum permissible motor temperature	100 °C
Number of phases	4
Resistance per coil	15 Ω

¹⁾ measured with 4-phase electronic switch 9904 131 03003 and with the coils connected according to Fig. 2b.

Inductance per coil	30 mH
Current per coil	330 mA
Power consumption of the motor	3.3 W
Insulation resistance at 500 V d.c.	100 M Ω

Fig.2a. Diagram for connecting the motor to the electronic switch via a printed-wiring connector, without compensating network.

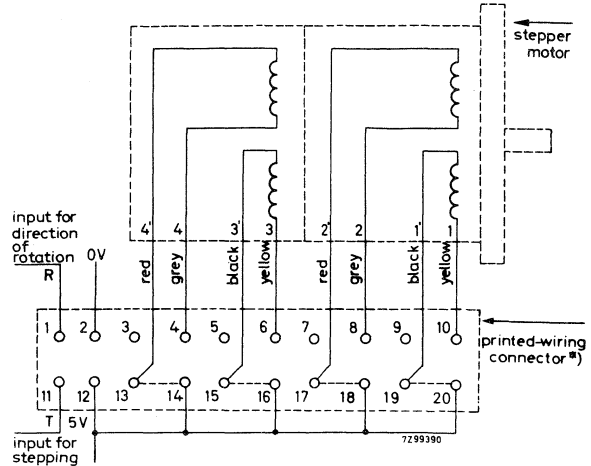
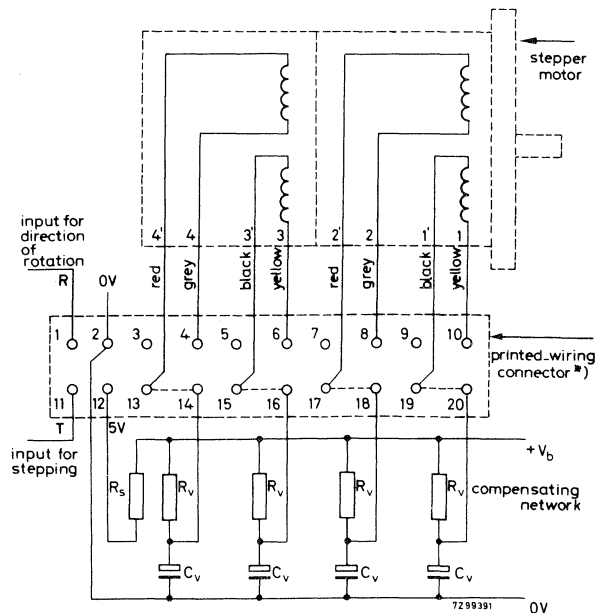

Fig.2b. Diagram for connecting the motor to the electronic switch via a printed-wiring connector, with compensating network.

$$R_V = 22 \Omega, C_V = 27 \mu\text{F},$$

$$V_b = 12 \text{ V d.c.}$$

$$R_S = (V_b - 5)/0.230 \Omega.$$



*) figures refer to terminals of electronic switch.

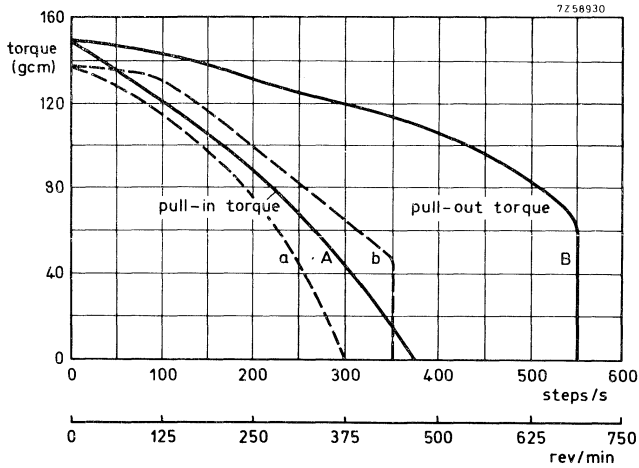

Fig. 3. Torque versus stepping rate. (Solid lines obtained with circuit of Fig. 2b, dashed lines obtained with circuit of Fig. 2a)

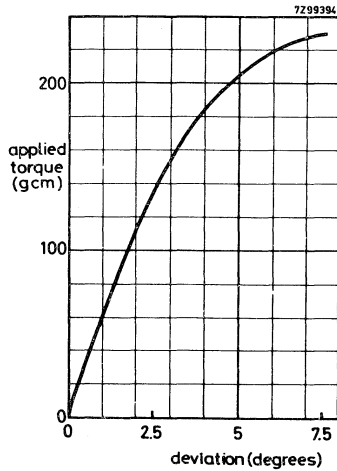

Fig. 4. Applied torque versus deviation.

STEPPER MOTOR

QUICK REFERENCE DATA

Step angle	7° 30'
Maximum torque	650 gcm *)
Holding torque	900 gcm *)
Maximum pull-in rate	240 steps/s
Maximum pull-out rate	360 steps/s

A 53191

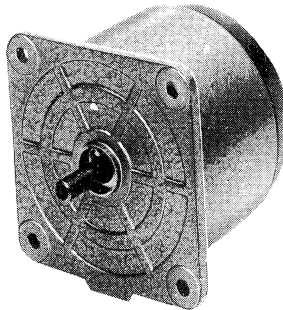

APPLICATION

This stepper motor has been designed for converting electrical digital information, supplied via an electronic switch, into mechanical movement. It can be used as a positioner or in a variable speed drive.

DESCRIPTION

The stepper motor has a 4-phase stator and a permanent magnet rotor with 24 poles in a rugged and simple construction. The motor coils are adapted to the electronic switch 9904 131 03003 (see relevant data sheet) for optimum performance.

*) 1 gcm = 10^{-4} Nm

TECHNICAL DATA

Dimensions (in mm) and connections

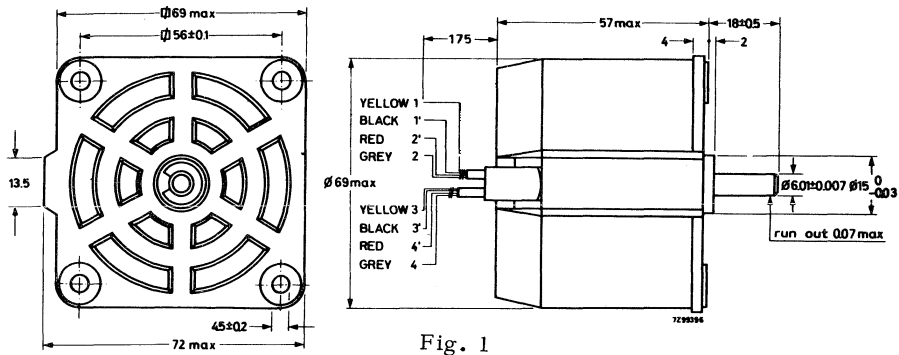

Fig. 1

Marking

The connecting leads are colour-coded, see Fig.1.

Maximum pull-ⁱⁿ_{out} torque

650 gcm

Holding torque

900 gcm

Maximum pull-in rate ¹⁾

240 steps/s

Maximum pull-out rate ¹⁾

360 steps/s

Number of steps per revolution

48

Step angle

 $7^\circ 30'$

Step angle tolerance

 $\pm 20'$ non cumulative

Direction of rotation

electrically reversible

Mass moment of inertia of the rotor

93 gcm²

Maximum axial force

500 g

Maximum radial force

1500 g

→ Bearings

needle

Weight

500 g

Ambient temperature range

operating

-20 to +70 °C

storage

-40 to +100 °C

Maximum permissible motor temperature

100 °C

Number of phases

4

Resistance per coil

9 Ω

Inductance per coil

25 mH

Current per coil

550 mA

¹⁾ measured with 4-phase electronic switch 9904 131 03003 and with the coils connected according to Fig. 2b.

Power consumption of the motor
Insulation resistance at 500 Vdc

5.5 W
100 M Ω

Fig.2a. Diagram for connecting the motor to the electronic switch via a printed-wiring connector, without compensating network.

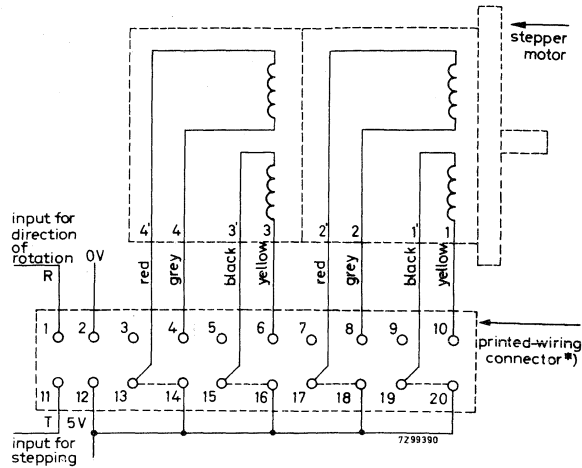
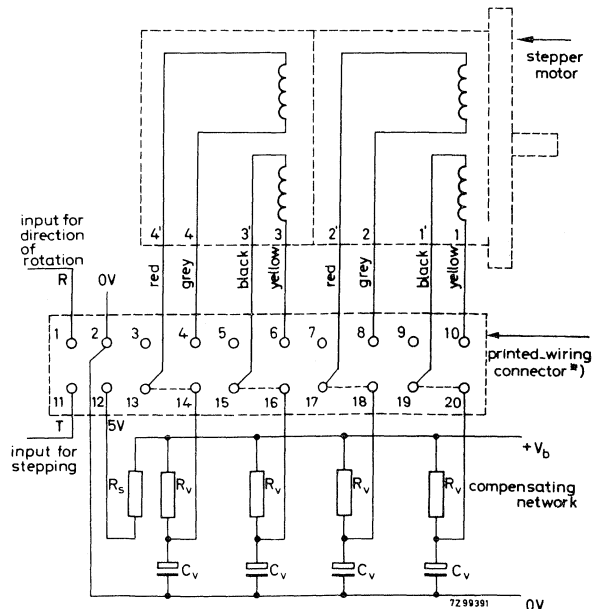

Fig.2b. Diagram for connecting the motor to the electronic switch via a printed-wiring connector, with compensating network.

$$R_V = 15 \Omega, C_V = 100 \mu\text{F},$$

$$V_B = 12 \text{ V d.c.}$$

$$R_S = (V_B - 5) / 0.230 \Omega.$$



*) figures refer to terminals of electronic switch.

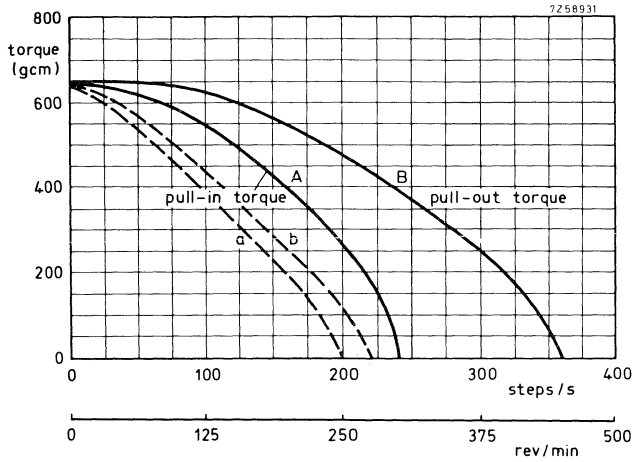

Fig. 3. Torque versus stepping rate. (Solid lines obtained with circuit of Fig. 2b, dashed lines obtained with circuit of Fig. 2a).

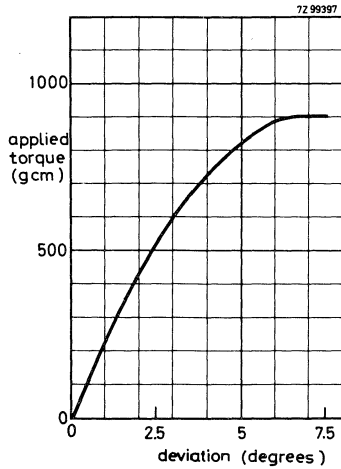
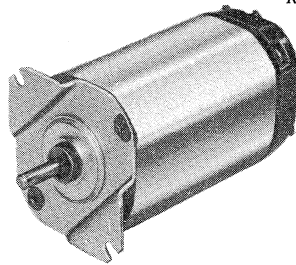

Fig. 4. Applied torque versus deviation.

STEPPER MOTOR

QUICK REFERENCE DATA	
Step angle	7° 30'
Maximum torque	500 gcm*)
Holding torque	700 gcm*)
Maximum pull-in rate	200 steps/s
Maximum pull-out rate	320 steps/s

RZ 26753-4



APPLICATION

This stepper motor has been designed for converting electrical digital information, supplied via an electronic switch, into mechanical movement. It can be used as a positioner or in a variable speed drive.

DESCRIPTION

The stepper motor has a 4-phase stator and a permanent magnet rotor with 24 poles in a rugged and simple construction. The motor coils are adapted to the electronic switch 9904 131 03003 (see relevant data sheet) for optimum performance.

*) 1 gcm = 10^{-4} Nm

TECHNICAL DATA

Dimensions (in mm) and connections

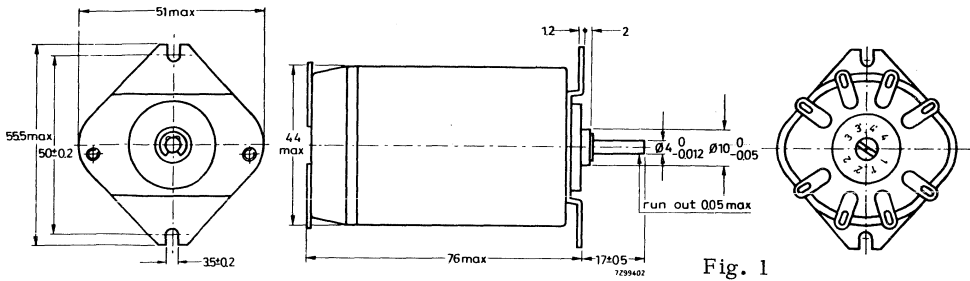

Fig. 1

Marking

The terminals are numbered as indicated in Fig. 1.

Maximum pull-in torque	500 gcm
Holding torque	700 gcm
Maximum pull-in rate 1)	200 steps/s
Maximum pull-out rate 1)	320 steps/s
Number of steps per revolution	48
Step angle	7° 30'
Step angle tolerance	± 20' non cumulative
Direction of rotation	electrically reversible
Mass moment of inertia of the rotor	90 gcm ²
Maximum axial force	150 g
Maximum radial force	1500 g
Bearings	sleeve
Weight	320 g
Ambient temperature range	
operating	-20 to +70 °C
storage	-40 to +100 °C
Maximum permissible motor temperature	100 °C
Number of phases	4
Resistance per coil	12 Ω
Inductance per coil	35 mH
Current per coil	400 mA
Power consumption of the motor	4 W
Insulation resistance at 500 V _{dc}	100 MΩ

1) measured with 4-phase electronic switch 9904 131 03003 and with the coils connected according to Fig. 2b.

Fig.2a. Diagram for connecting the motor to the electronic switch via a printed-wiring connector, without compensating network.

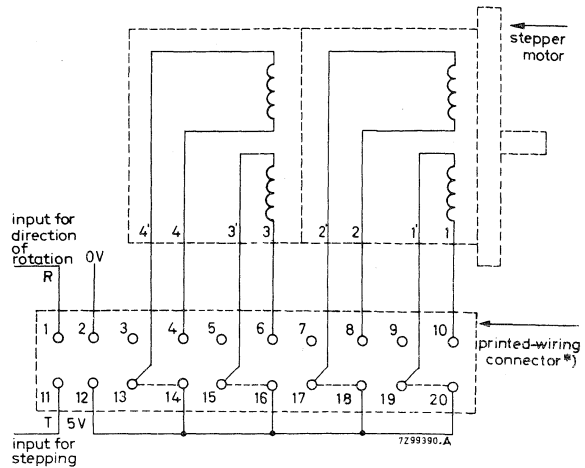
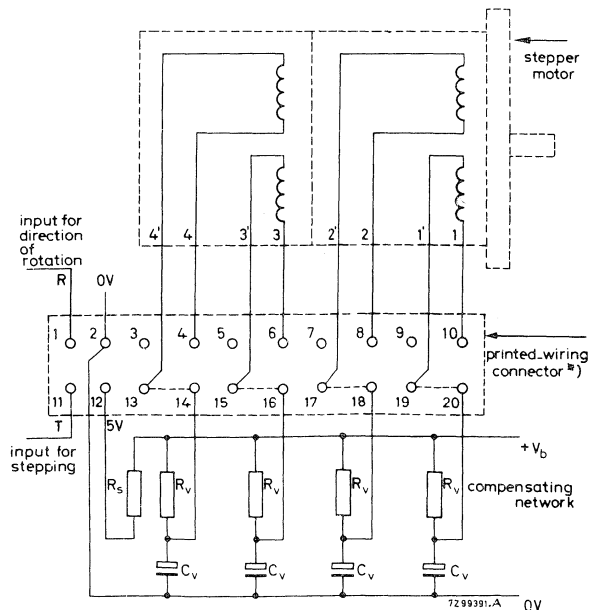

Fig.2b. Diagram for connecting the motor to the electronic switch via a printed-wiring connector, with compensating network.

$$R_V = 15 \Omega, C_V = 50 \mu\text{F},$$

$$V_b = 12 \text{ V d.c.}$$

$$R_s = (V_b - 5)/0.230 \Omega$$



*) figures refer to terminals of electronic switch.

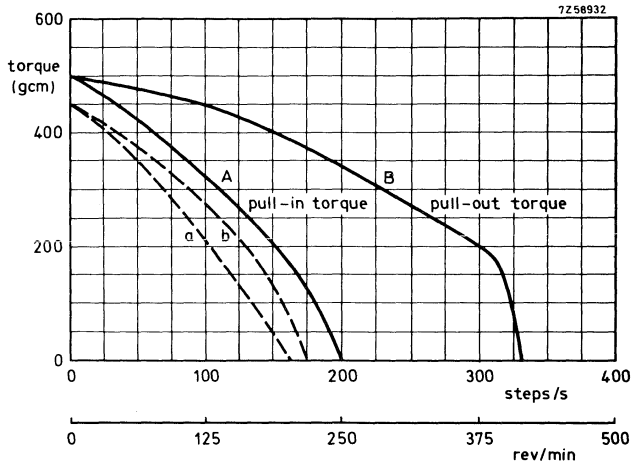

Fig.3. Torque versus stepping rate. (Solid lines obtained with circuit of Fig.2b, dashed lines obtained with circuit of Fig.2a)

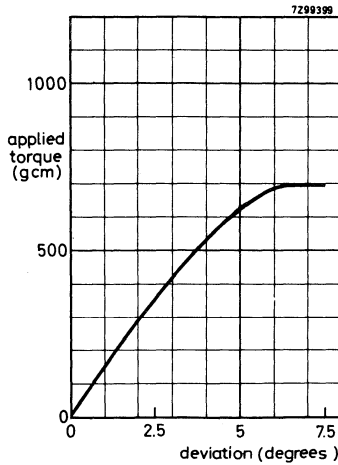
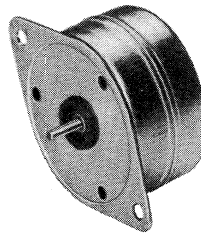

Fig.4. Applied torque versus deviation

STEPPER MOTOR

QUICK REFERENCE DATA	
Step angle	7° 30'
Maximum torque	60 gcm *)
Holding torque	80 gcm *)
Maximum pull-in rate	500 steps/s
Maximum pull-out rate	1000 steps/s



RZ 26753-10

APPLICATION

This stepper motor has been designed for converting electrical digital information, supplied via an electronic switch, into mechanical movement. It can be used as a positioner or in a variable speed drive.

DESCRIPTION

The stepper motor has a 4-phase stator and a permanent magnet rotor with 24 poles in a rugged and simple construction. The motor coils are adapted to the electronic switch 9904 131 03003 (see relevant data sheet) for optimum performance.

*) 1 gcm = 10^{-4} Nm

TECHNICAL DATA

Dimensions (in mm) and connections

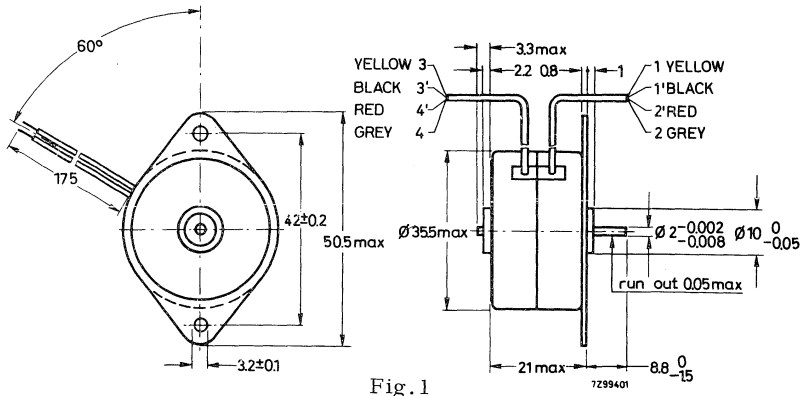

Fig. 1

Marking

The connecting leads are colour-coded, see Fig. 1.

Maximum pull-out torque	60 gcm
Holding torque	80 gcm
Maximum pull-in rate 1)	500 steps/s
Maximum pull-out rate 1)	1000 steps/s
Number of steps per revolution	48
Step angle	7° 30'
Step angle tolerance	± 40' non cumulative
Direction of rotation	electrically reversible
Mass moment of inertia of the rotor	2.6 gcm ²
Maximum axial force	75 g
Maximum radial force	250 g
Bearings	sleeve
Weight	75 g
Ambient temperature range	
operating	-20 to + 70 °C
storage	-40 to +100 °C
Maximum permissible motor temperature	100 °C
Number of phases	4
Resistance per coil	25 Ω
Inductance per coil	30 mH
Current per coil	175 mA

1) measured with 4-phase electronic switch 9904 131 03003 and with the coils connected according to Fig. 2b.

Power consumption of the motor
Insulation resistance at 500 V_{dc}

1.7 W
100 M Ω

Fig.2a. Diagram for connecting the motor to the electronic switch via a printed-wiring connector, without compensating network.

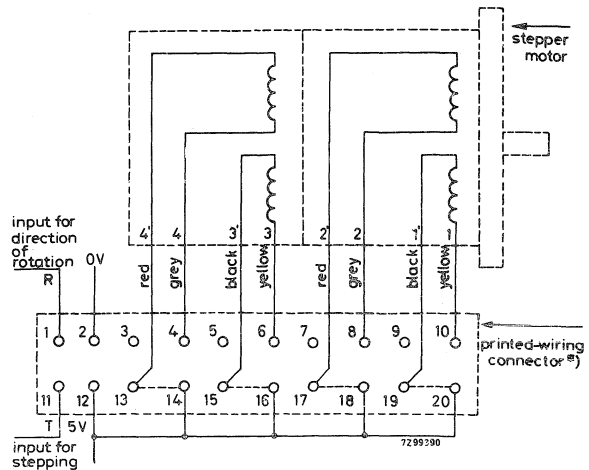
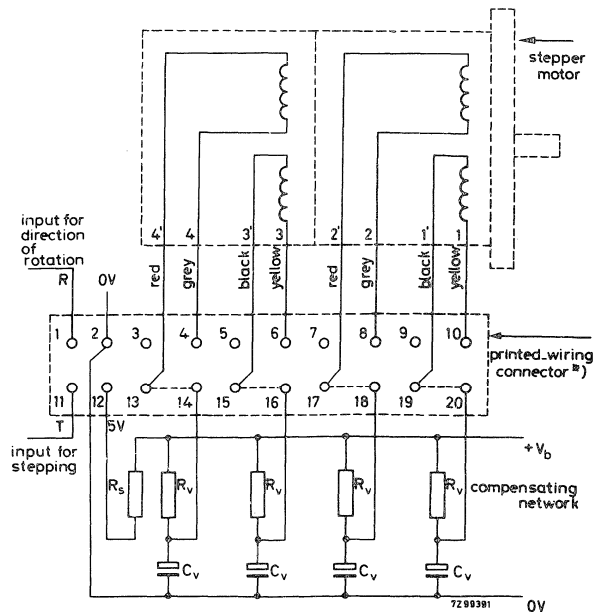

Fig.2b. Diagram for connecting the motor to the electronic switch via a printed-wiring connector, with compensating network.

$$R_v = 43 \Omega, C_v = 27 \mu\text{F},$$

$$V_b = 12 \text{ V d.c.}$$

$$R_s = (V_b - 5)/0.230 \Omega.$$



*) figures refer to terminals of electronic switch.

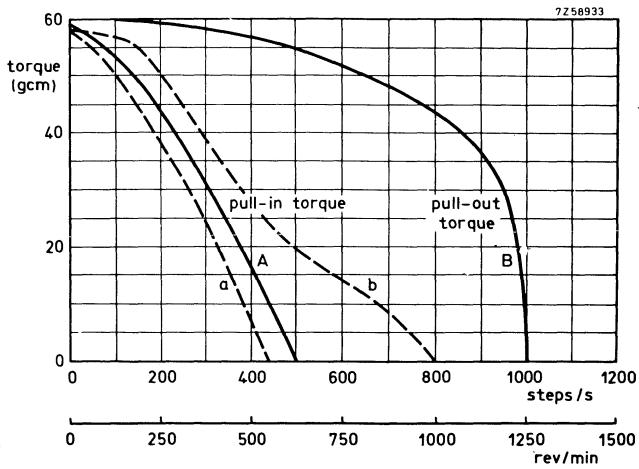

Fig. 3. Torque versus stepping rate. (Solid lines obtained with circuit of Fig. 2b, dashed lines obtained with circuit of Fig. 2a).

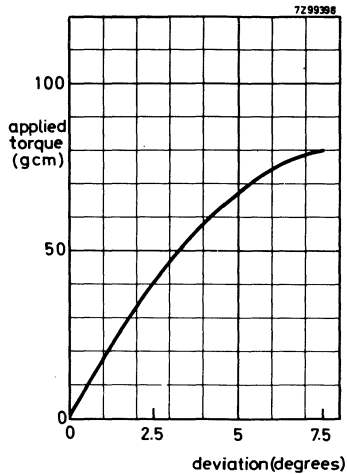
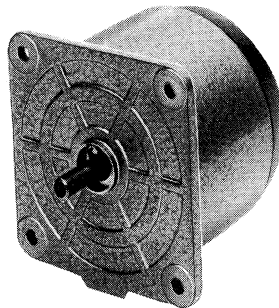

Fig. 4. Applied torque versus deviation.

STEPPER MOTOR

QUICK REFERENCE DATA

Step angle	15°
Maximum torque	350 gcm *)
Holding torque	650 gcm *)
Maximum pull-in rate	160 steps/s
Maximum pull-out rate	450 steps/s



A 53191

APPLICATION

This stepper motor has been designed for converting electrical digital information, supplied via an electronic switch, into mechanical movement. It can be used as a positioner or in a variable speed drive.

DESCRIPTION

The stepper motor has a 4-phase stator and a permanent magnet rotor with 12 poles in a rugged and simple construction. The motor coils are adapted to the electronic switch 9904 131 03003 (see relevant data sheet) for optimum performance.

*) 1 gcm = 10^{-4} Nm

TECHNICAL DATA

Dimensions (in mm) and connections

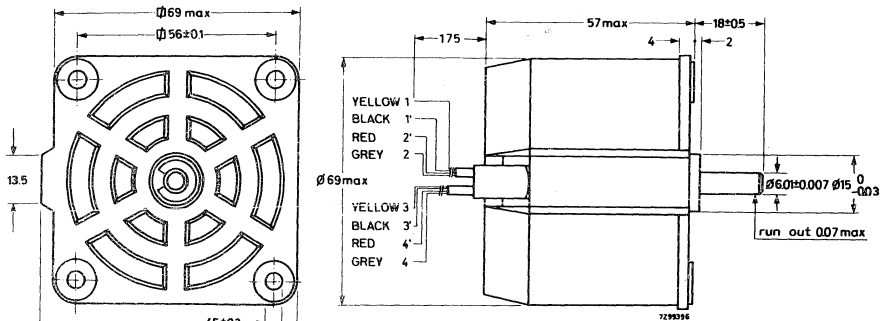

Fig. 1.

Marking

The connecting leads are colour-coded, see Fig. 1.

Maximum pull-in torque	350 gcm
Holding torque	650 gcm
Maximum pull-in rate ¹⁾	160 steps/s
Maximum pull-out rate ¹⁾	400 steps/s
Number of steps per revolution	24
Step angle	15°
Step angle tolerance	$\pm 30'$ non cumulative
Direction of rotation	electrically reversible
Mass moment of inertia of the rotor	93 gcm ²
Maximum axial force	500 g
Maximum radial force	1500 g
→ Bearings	needle
Weight	500 g
Ambient temperature range	
operating	-20 to +70 °C
storage	-40 to +100 °C
Maximum permissible motor temperature	100 °C
Number of phases	4
Resistance per coil	9 Ω
Inductance per coil	20 mH
Current per coil	550 mA
Power consumption of the motor	5.5 W
Insulation resistance at 500 V _{dc}	100 MΩ

¹⁾ measured with 4-phase electronic switch 9904 131 03003 and with the coils connected according to Fig. 2b.

Fig. 2a. Diagram for connecting the motor to the electronic switch via a printed-wiring connector, without compensating network.

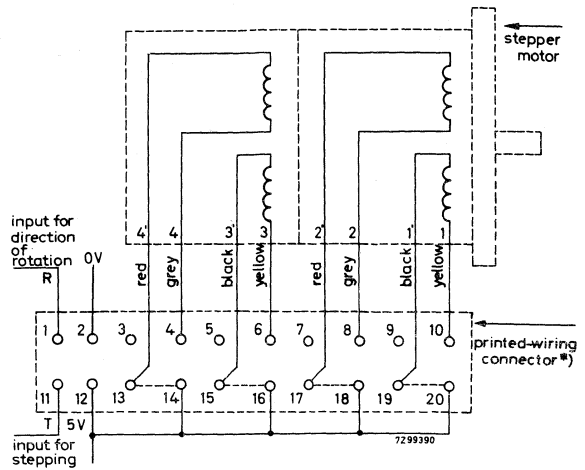
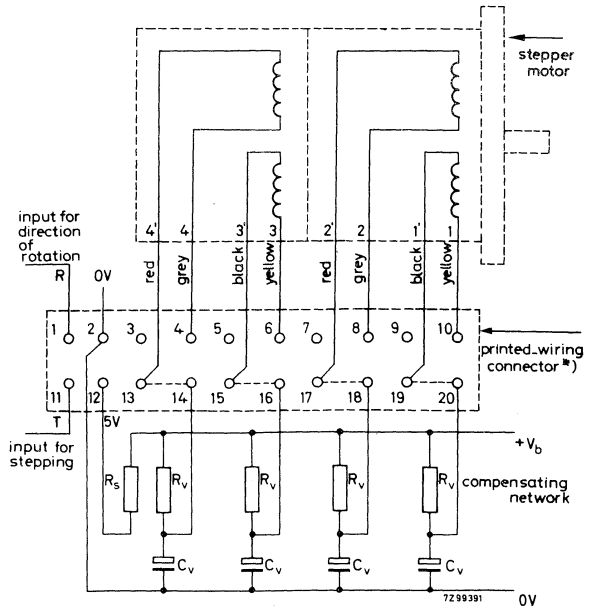

Fig. 2b. Diagram for connecting the motor to the electronic switch via a printed-wiring connector, with compensating network.

$$R_v = 15 \Omega, C_v = 100 \mu F,$$

$$V_b = 12 \text{ V d.c.}$$

$$R_s = (V_b - 5)/0.230 \Omega.$$



*) figures refer to terminals of electronic switch.

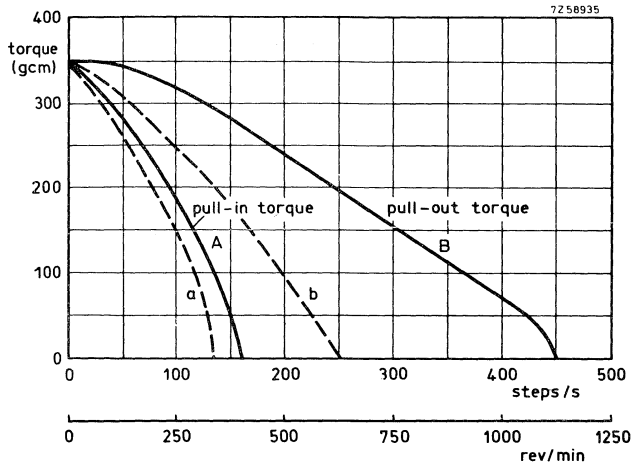

Fig. 3. Torque versus stepping rate. (Solid lines obtained with circuit of Fig. 2b, dashed lines obtained with circuit of Fig. 2a).

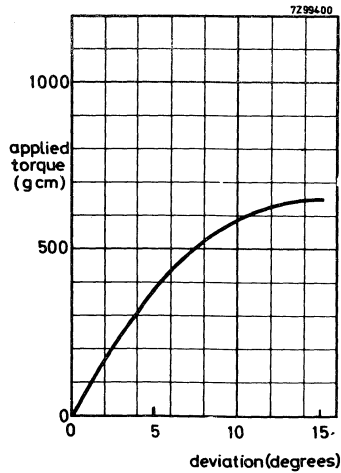
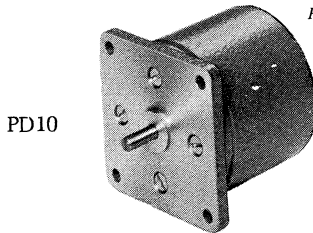

Fig. 4. Applied torque versus deviation.

STEPPER MOTORS

QUICK REFERENCE DATA	
Step angle	7° 30'
Maximum torque	70 gcm *)
Holding torque	100 gcm *)
Maximum pull-in rate	500 steps/s
Maximum pull-out rate	1000 steps/s



RZ 26753-16

SMD11

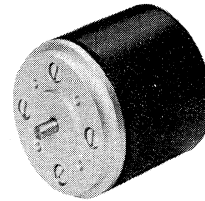

RZ 26753-18

APPLICATION

These stepper motors have been designed for converting electrical digital information, supplied via an electronic switch, into mechanical movement. They can be used as positioners or in variable speed drives.

DESCRIPTION

The stepper motors have a 4-phase stator and a permanent magnet rotor with 24 poles all enclosed in a robust aluminium housing. The motor coils are adapted to the electronic switch 9904 131 03003 (see relevant data sheet) for optimum performance. The PD10 has a square mounting flange while the SMD11 is provided with a so-called servo-flange (size 15) and meets standard servo-mount requirements. The motors are characterized by their robust design and if desired they can be made to satisfy MIL specifications.

*) 1 gcm = 10^{-4} Nm

TECHNICAL DATA

Dimensions

Fig. 1a.
PD10 in mm

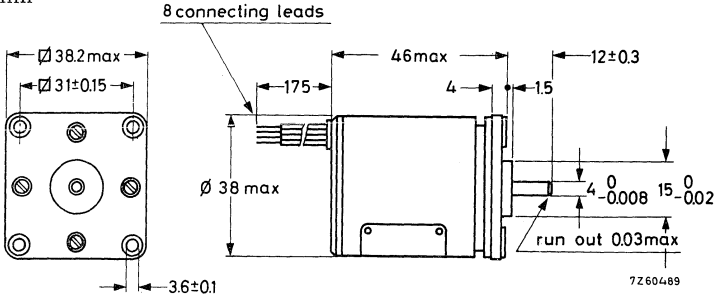
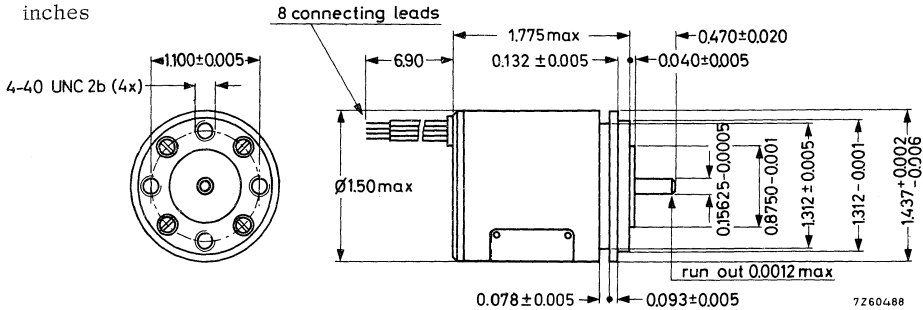

Fig. 1b.
SMD11 in
inches



Marking

The connecting leads are colour-coded, see Fig. 2

Maximum pull-out torque	70 gcm
Holding torque	100 gcm
Maximum pull-in rate ¹⁾	≥ 500 steps/s
Maximum pull-out rate ¹⁾	≥ 1000 steps/s
Number of steps per revolution	48
Step angle	7° 30'
Step angle tolerance	± 20' non cumulative
Direction of rotation	electrically reversible
Mass moment of inertia of the rotor	3.5 gcm ²

¹⁾ measured with 4-phase electronic switch 9904 131 03003 (see relevant data sheet) and with the coils connected according to Fig. 2b.

Maximum axial play (axial force 150 g)	0.08 mm
Maximum axial force	500 g
Maximum radial force	1000 g
Bearings	ball-bearings
Weight	140 g
Ambient temperature range	
operating	up to +85 °C
storage	up to +110 °C
Maximum permissible motor temp.	125 °C
Number of phases	4
Resistance per coil	27 Ω
Inductance per coil	20 mH
Current per coil	175 mA
Power consumption of the motor	1.75 W
Insulation resistance at 500 V d.c.	100 MΩ

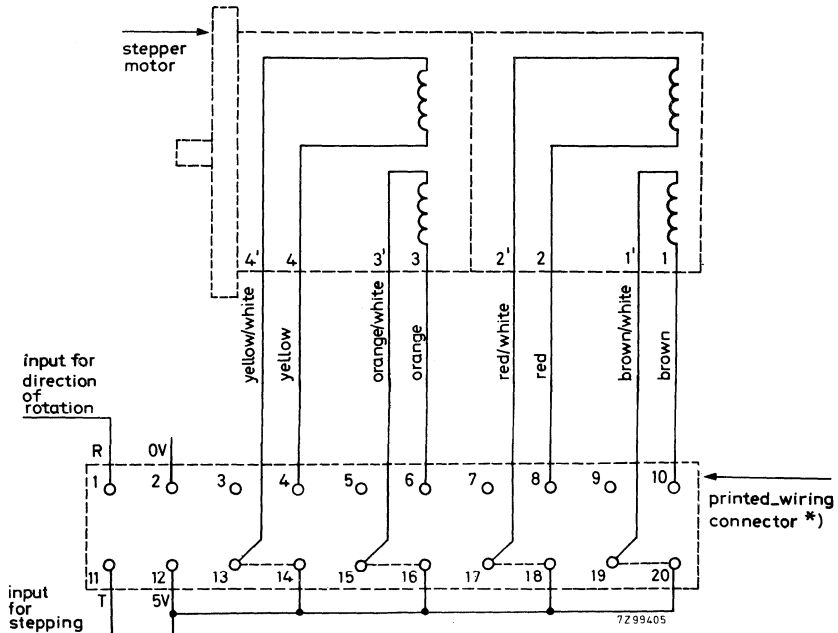

Fig. 2a. Diagram for connecting the motor to the electronic switch via a printed-wiring connector, without compensating network.

*) Figures refer to terminals of electronic switch.

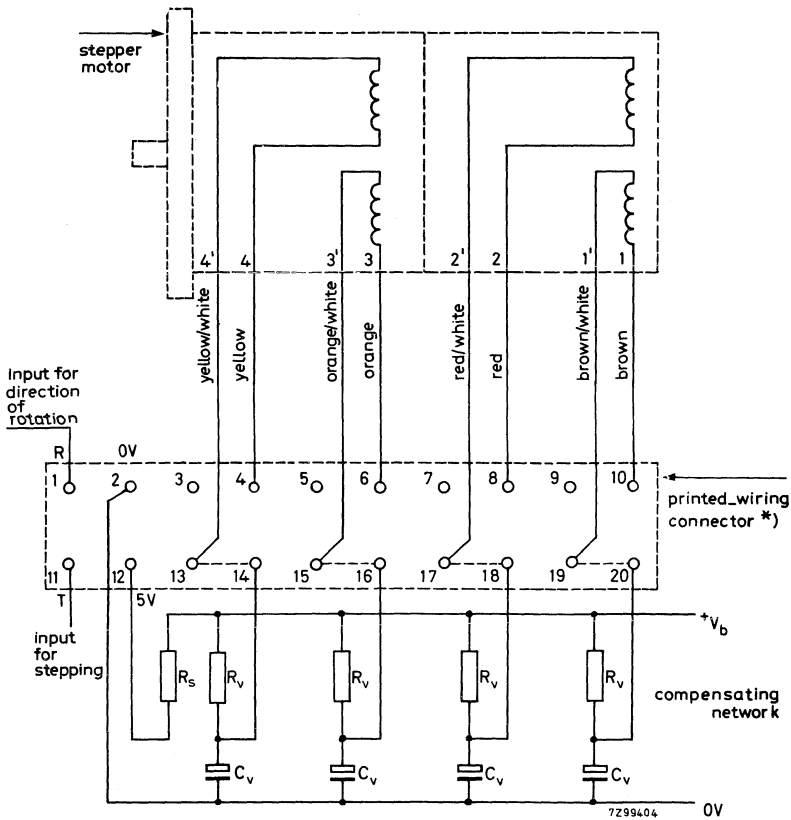

Fig. 2b. Diagram for connecting the motor to the electronic switch via a printed-wiring connector, with compensating network.

$$R_v = 47 \Omega (\pm 5\%), 2 \text{ W}; C_v = 10 \mu\text{F}, 64 \text{ V d.c.}; V_b = 12 \text{ V d.c.};$$

$$R_s = (V_b - 5) / 0.230 \Omega$$

*) Figures refer to terminals of electronic switch.

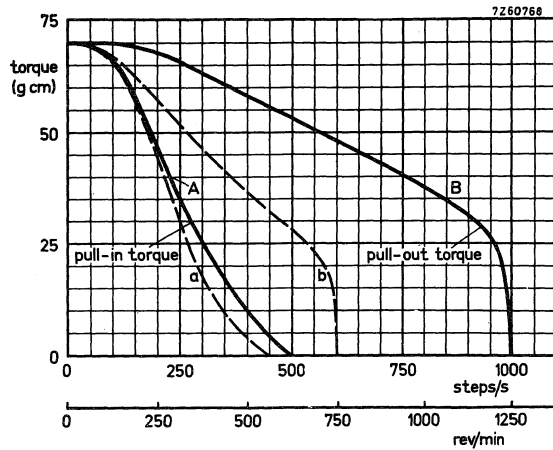

Fig. 3. Torque versus stepping rate, measured at room temperature. (Solid lines obtained with circuit of Fig. 2b, dashed lines obtained with circuit of Fig. 2a). Derating at low and high temperatures.

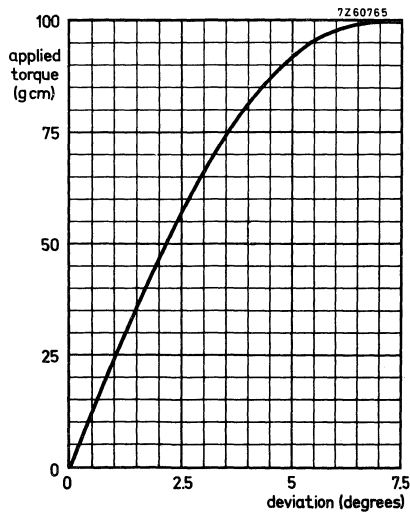
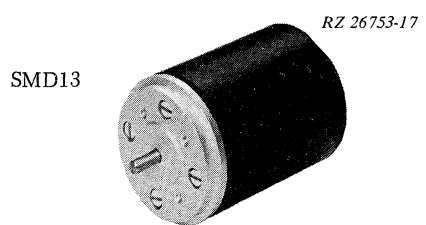
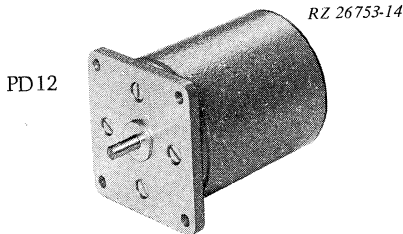

Fig. 4. Applied torque versus deviation.

STEPPER MOTORS

QUICK REFERENCE DATA	
Step angle	3° 45'
Maximum torque	150 gcm *)
Holding torque	180 gcm *)
Maximum pull-in rate	1200 steps/s
Maximum pull-out rate	16000 steps/s



APPLICATION

These stepper motors have been designed for converting electrical digital information, supplied via an electronic switch, into mechanical movement. They can be used as positioners or in variable speed drives.

DESCRIPTION

The stepper motors have an 8-phase stator and a permanent magnet rotor with 24 poles all enclosed in a robust aluminium housing. The motor coils are adapted to the electronic switch 9904 131 03004 (see relevant data sheet) for optimum performance. The PD12 has a square mounting flange while the SMD13 is provided with a so-called servo-flange (size 15) and meets standard servo-mount requirements. The motors are characterized by their robust design and if desired they can be made to satisfy MIL specifications.

*) 1 gcm = 10⁻⁴ Nm

TECHNICAL DATA

Dimensions

Fig. 1a.
PD12 in mm

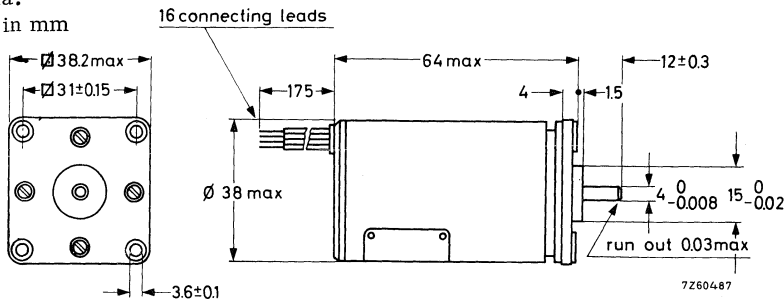
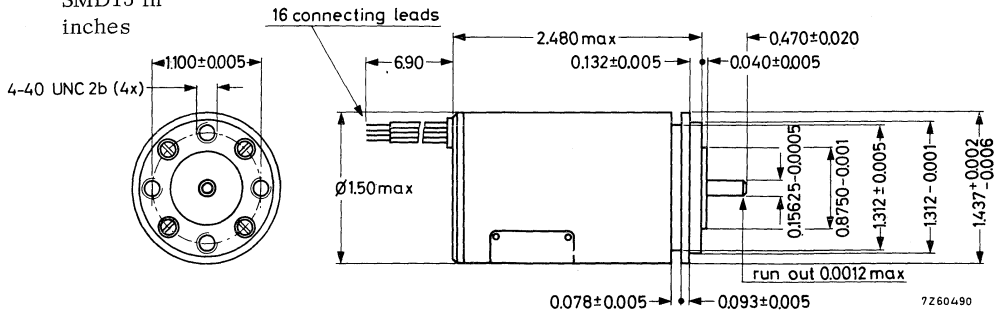

Fig. 1b.
SMD13 in inches



Marking

The connecting leads are colour-coded, see Fig. 2

Maximum pull-in torque	150 gcm
Holding torque	180 gcm
Maximum pull-in rate ¹⁾	1200 steps/s
Maximum pull-out rate ¹⁾	16000 steps/s
Number of steps per revolution	96
Step angle	$3^\circ 45'$
Step angle tolerance	$\pm 20'$ non cumulative
Direction of rotation	electrically reversible
Mass moment of inertia of the rotor	7 gcm^2

¹⁾ measured with 8-phase electronic switch 9904 131 03004 (see relevant data sheet) and with the coils connected according to Fig. 2b.

PD12
SDM13

STEPPER MOTORS

9904 112 12001
9904 112 13001

Maximum axial play (axial force 150 g)	0.08 mm
Maximum axial force	500 g
Maximum radial force	1000 g
Bearings	ball-bearings
Weight	220 g
Ambient temperature range	
operating	up to +85 °C
storage	up to +110 °C
Maximum permissible motor temp.	125 °C
Number of phases	8
Resistance per coil	27 Ω
Inductance per coil	20 mH
Current per coil	175 mA
Power consumption of the motor	3.5 W
Insulation resistance at 500 V d. c.	100 MΩ



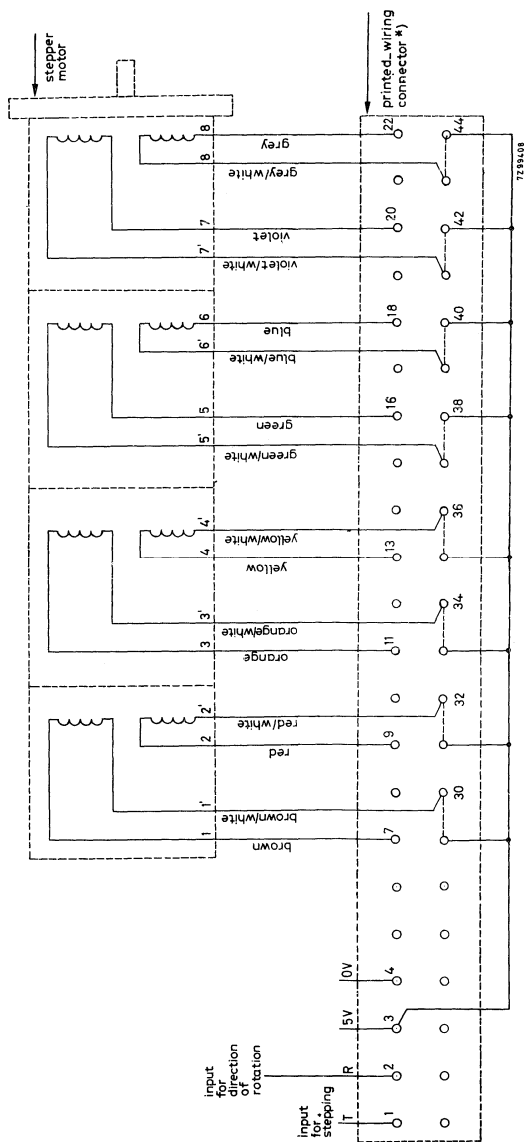

Fig. 2a. Diagram for connecting the motor to the electronic switch via a printed-wiring connector, without compensating network.

*) Figures refer to terminals of electronic switch.

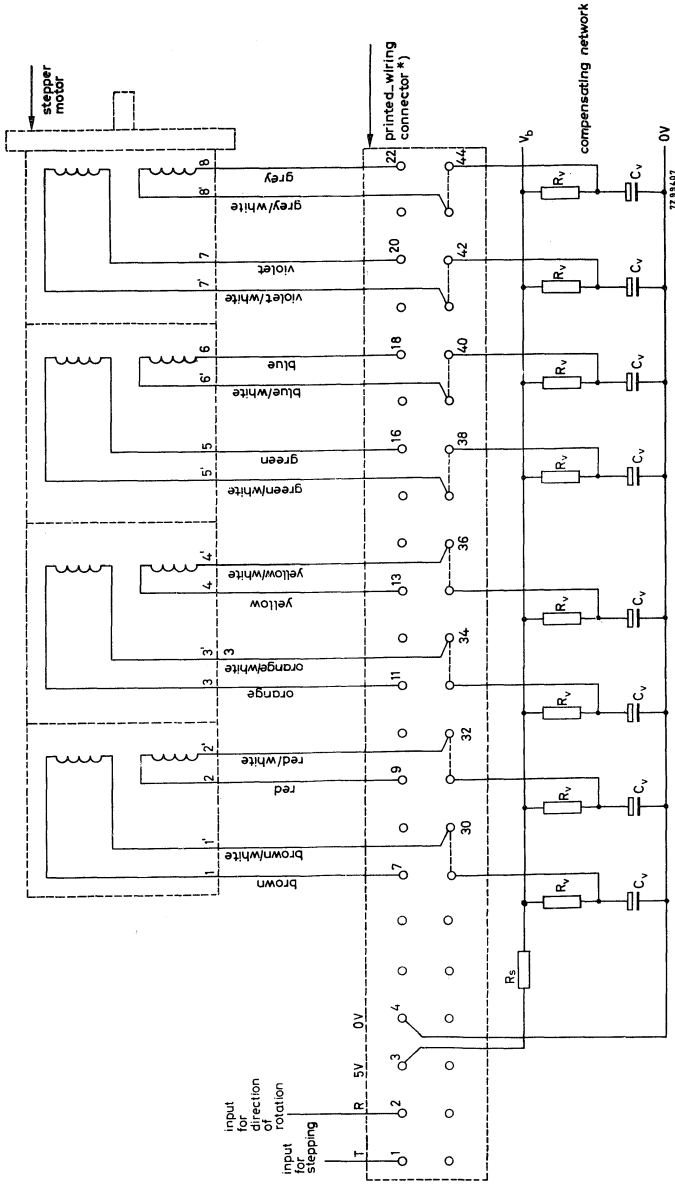

Fig. 2b. Diagram for connecting the motor to the electronic switch via a printed-wiring connector, with compensating network.

$R_V = 91 \Omega (\pm 5\%), 5W; C_V = 10 \mu F, 64 V d.c.; V_B = 20 V d.c.; R_S = (V_B - 5)/0.440 \Omega$

*) Figures refer to terminals of electronic switch.



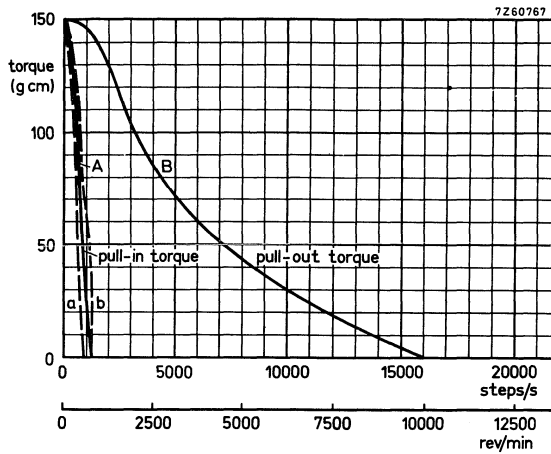

Fig. 3. Torque versus stepping rate, measured at room temperature. (Solid lines obtained with circuit of Fig. 2b, dashed lines obtained with circuit of Fig. 2a). Derating at low and high temperatures.

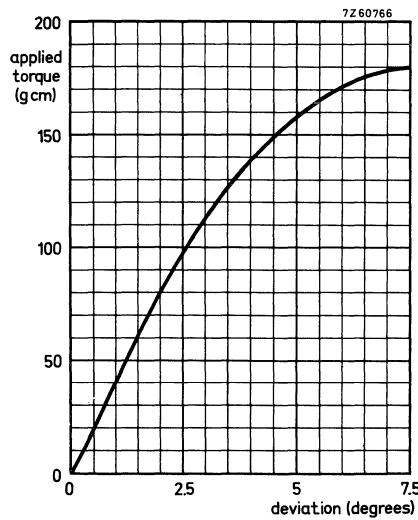
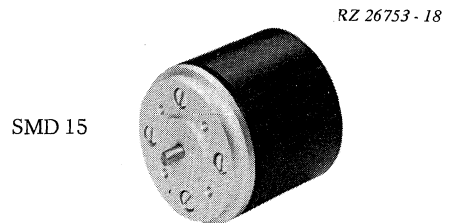
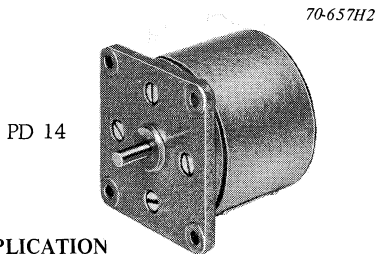

Fig. 4. Applied torque versus deviation.

STEPPER MOTORS

QUICK REFERENCE DATA	
Step angle	7° 30'
Maximum torque	250 gcm *)
Holding torque	350 gcm *)
Maximum pull-in rate	360 steps/s
Maximum pull-out rate	550 steps/s



APPLICATION

These stepper motors have been designed for converting electrical digital information, supplied via an electronic switch, into mechanical movement. They can be used as positioners or in variable speed drives.

DESCRIPTION

The stepper motors have a 4-phase stator and a permanent magnet rotor with 24 poles all enclosed in a robust aluminium housing. The motor coils are adapted to the electronic switch 9904 131 03003 (see relevant data sheet) for optimum performance. The PD14 has a square mounting flange while the SMD15 is provided with a so-called servo-flange (size 23) and meets standard servo-mount requirements. The motors are characterized by their robust design and if desired they can be made to satisfy MIL specifications.

*) 1 gcm = 10^{-4} Nm

TECHNICAL DATA

Dimensions

Fig. 1a.
PD 14
(in mm)

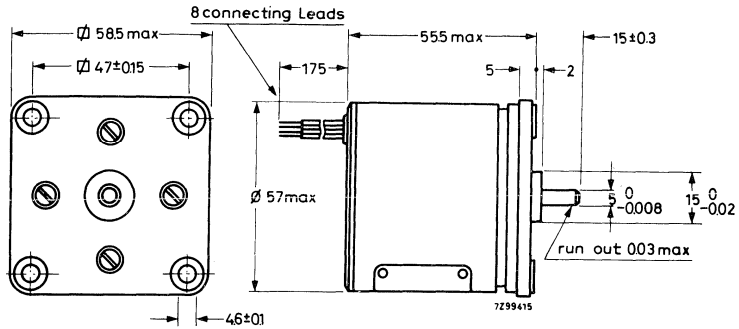
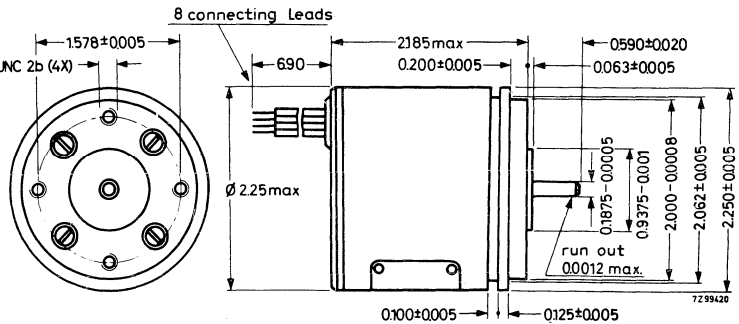

Fig. 1b.
SMD 15
(in inches)



Marking

The connecting leads are colour-coded, see Fig. 2

Maximum pull-in torque	250 gcm
Holding torque	350 gcm
Maximum pull-in rate ¹⁾	360 steps/s
Maximum pull-out rate ¹⁾	550 steps/s
Number of steps per revolution	48
Step angle	$7^\circ 30'$
Step angle tolerance	$\pm 10'$ non cumulative
Direction of rotation	electrically reversible
Mass moment of inertia of the rotor	18 gcm^2

¹⁾ measured with 4-phase electronic switch 9904 131 03003 and with the coils connected according to Fig. 2b.

Maximum axial play (axial force 150 g)	0.07 mm
Maximum axial force	750 g
Maximum radial force	1500 g
Bearings	ball
Weight	500 g
Ambient temperature range	
operating	-54 to +85 °C
storage	-62 to +110 °C
Maximum permissible motor temperature	125 °C
Number of phases	4
Resistance per coil	15 Ω
Inductance per coil	25 mH
Current per coil	350 mA
Power consumption of the motor	3.7 W
Insulation resistance at 500 V _{dc}	100 MΩ

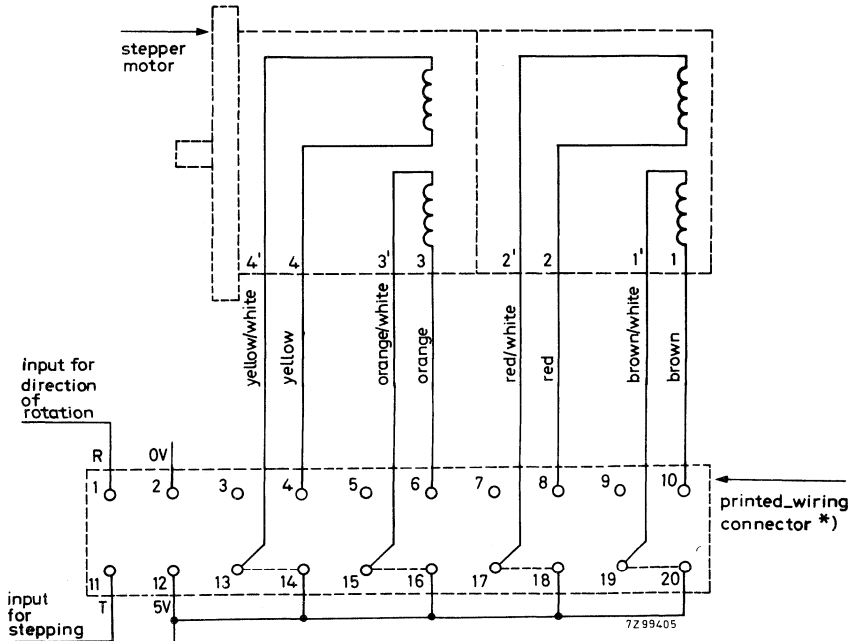

Fig. 2a. Diagram for connecting the motor to the electronic switch via a printed-wiring connector, without compensating network.

*) Figures refer to terminals of electronic switch.

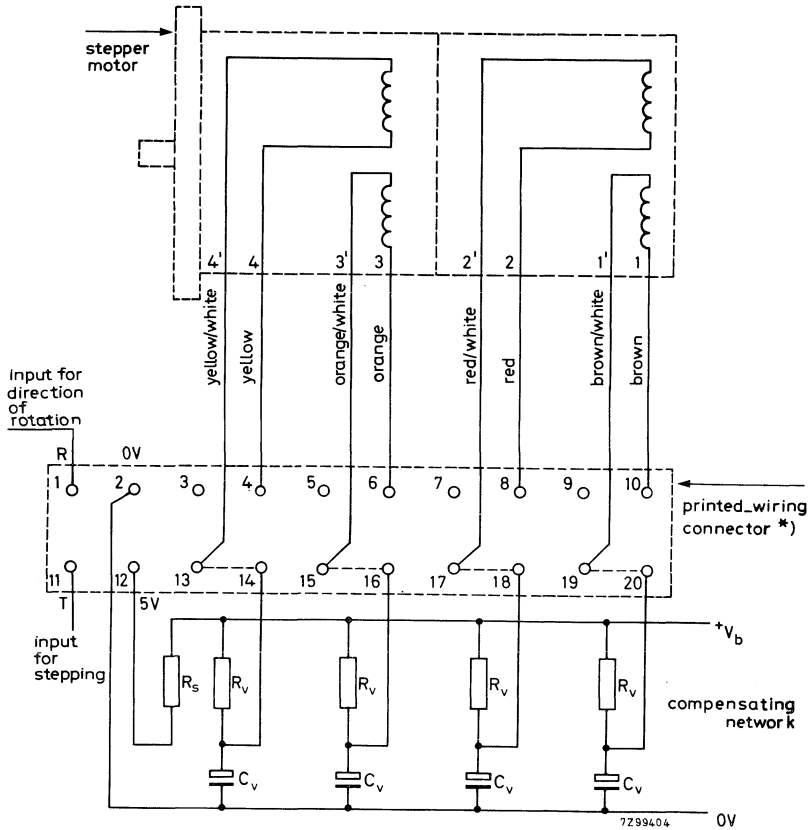

Fig. 2b. Diagram for connecting the motor to the electronic switch via a printed-wiring connector, with compensating network.

$R_v = 18 \Omega (\pm 5\%)$, 5 W; $C_v = 50 \mu\text{F}$, 40 V d. c. ; $V_b = 12 \text{ V d. c.}$;

$$R_s = (V_b - 5)/0.230 \Omega$$

*) Figures refer to terminals of electronic switch.

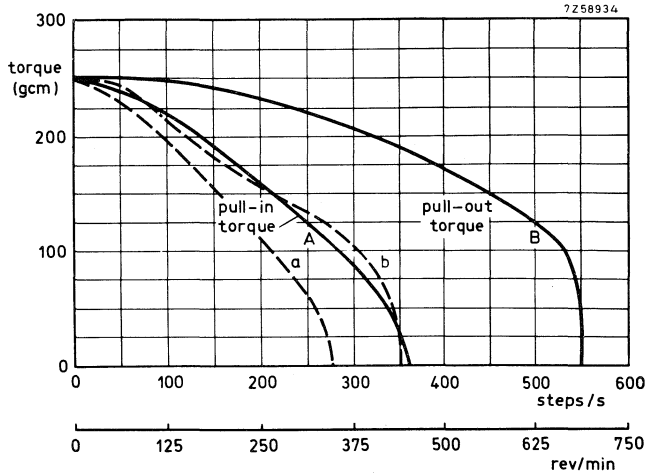

Fig. 3. Torque versus stepping rate, measured at room temperature. (Solid lines obtained with circuit of Fig. 2b, dashed lines obtained with circuit of Fig. 2a). Derating at low and high temperatures.

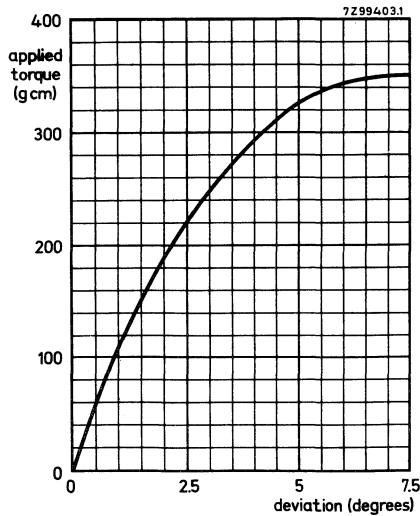
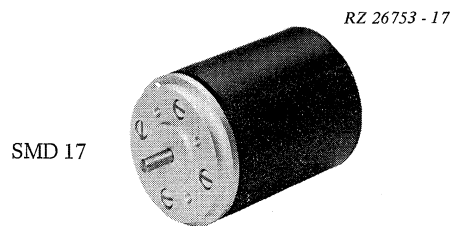
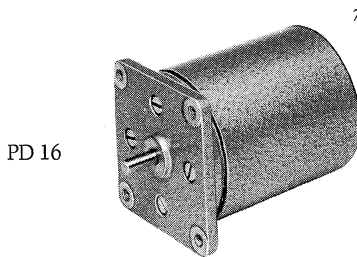

Fig. 4. Applied torque versus deviation.

STEPPER MOTORS

QUICK REFERENCE DATA	
Step angle	3° 45'
Maximum torque	400 gcm *)
Holding torque	500 gcm *)
Maximum pull-in rate	900 steps/s
Maximum pull-out rate	7500 steps/s



APPLICATION

These stepper motors have been designed for converting electrical digital information, supplied via an electronic switch, into mechanical movement. They can be used as positioners or in variable speed drives.

DESCRIPTION

The stepper motors have an 8-phase stator and a permanent magnet rotor with 24 poles, all enclosed in a robust aluminium housing. The motor coils are adapted to the electronic switch 9904 131 03004 (see relevant data sheet) for optimum performance.

The PD16 has a square mounting flange while the SMD17 is provided with a so-called servo-flange (size 23) and meets standard servo-mount requirements. The motors are characterized by their robust design and if desired they can be made to satisfy MIL specifications.

*) 1 gcm = 10⁻⁴ Nm

TECHNICAL DATA

Dimensions

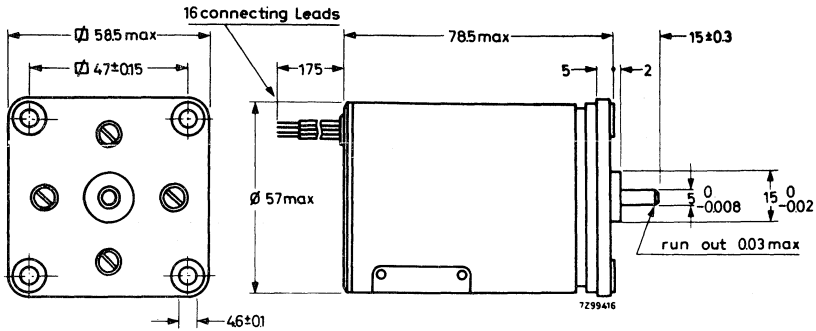

Fig. 1a. PD 16 (in mm)

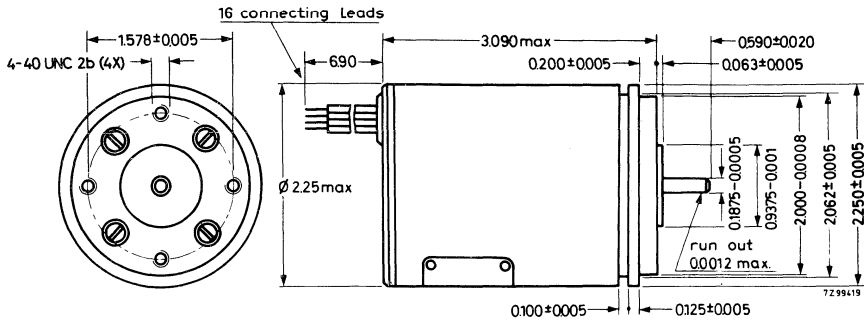

Fig. 1b. SMD 17 (in inches)

Marking

The connecting leads are colour-coded, see Fig. 2.

Maximum pull-in out torque	400 gcm
Holding torque	500 gcm
Maximum pull-in rate ¹⁾	900 steps/s
Maximum pull-out rate ¹⁾	7500 steps/s
Number of steps per revolution	96
Step angle	3° 45'
Step angle tolerance	± 10' non cumulative
Direction of rotation	electrically reversible
Mass moment of inertia of the rotor	32 gcm ²
Maximum axial play (axial force 150 g)	0.07 mm
Maximum axial force	750 g
Maximum radial force	1500 g
Bearings	ball
Weight	600 g
Ambient temperature range	
operating	-54 to + 85 °C
storage	-62 to +110 °C
Maximum permissible motor temp.	125 °C
Number of phases	8
Resistance per coil	15 Ω
Inductance per coil	25 mH
Current per coil	350 mA
Power consumption of the motor	6.5 W
Insulation resistance at 500 V _{dc}	100 MΩ



¹⁾ measured with 8-phase electronic switch 9904 131 03004 and with the coils connected according to Fig. 2b.

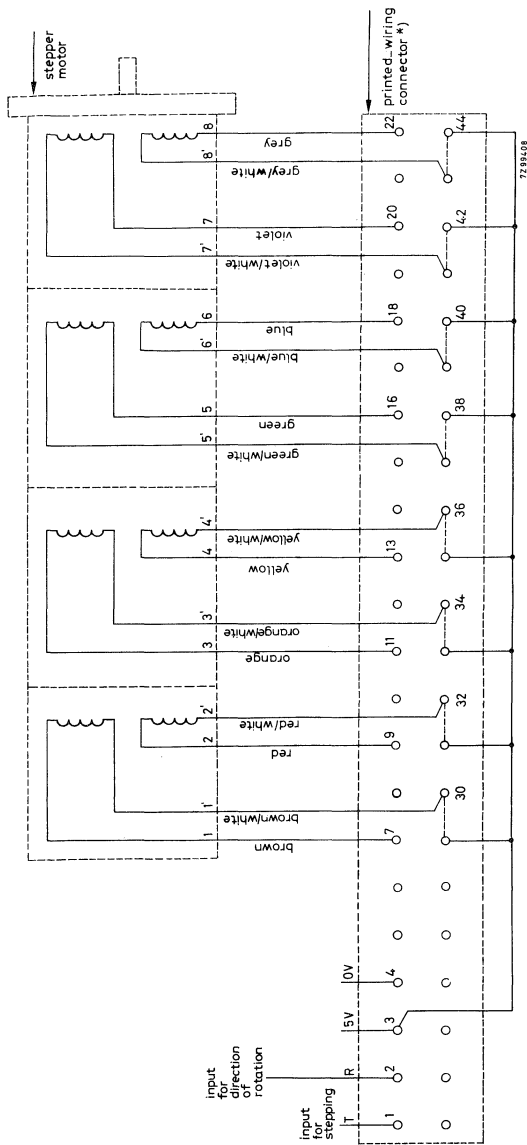

Fig.2a. Diagram for connecting the motor to the electronic switch via a printed-wiring connector, without compensating network.

*) Figures refer to terminals of electronic switch.

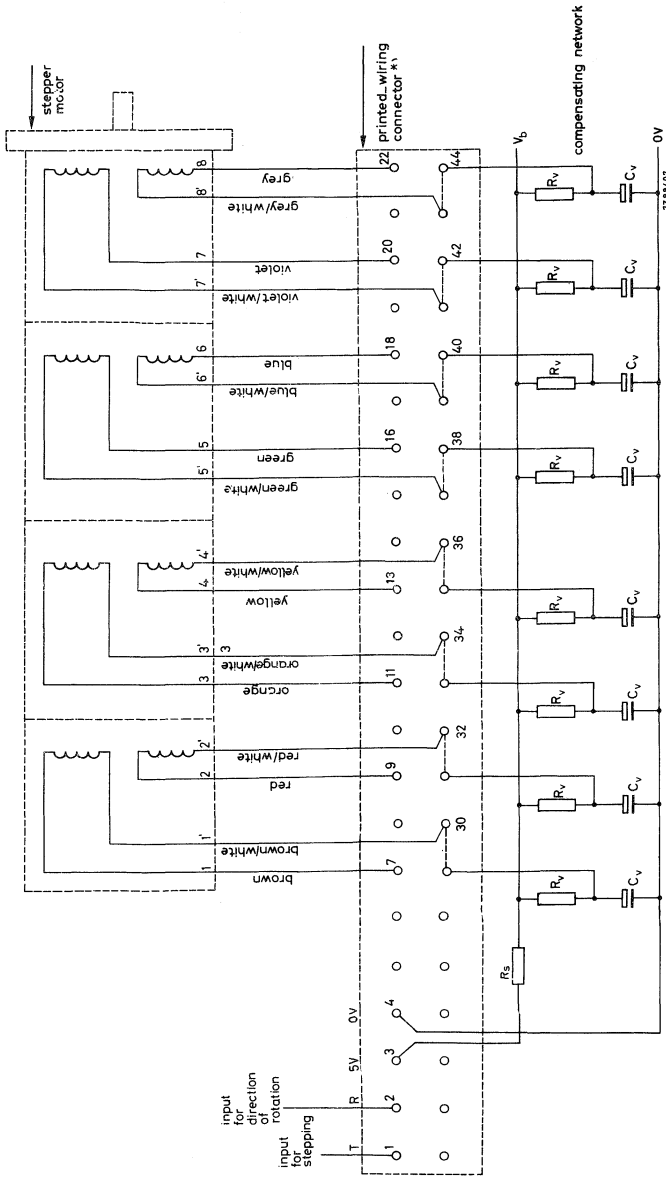

Fig. 2b. Diagram for connecting the motor to the electronic switch via a printed-wiring connector, with compensating network.

$R_v = 50 \Omega$ ($\pm 5\%$), $8 W$; $C_v = 25 \mu F$, $40 V$ d.c.; $V_b = 20 V$ d.c.; $R_s = (V_b - 5)/0.440 \Omega$

*) Figures refer to terminals of electronic switch.



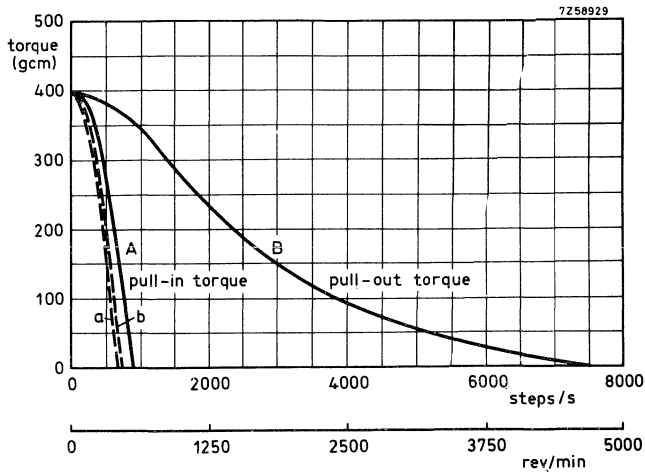

Fig. 3. Torque versus stepping rate, measured at room temperature. (Solid lines obtained with circuit of Fig. 2b, dashed lines obtained with circuit of Fig. 2a). Derating at low and high temperatures.

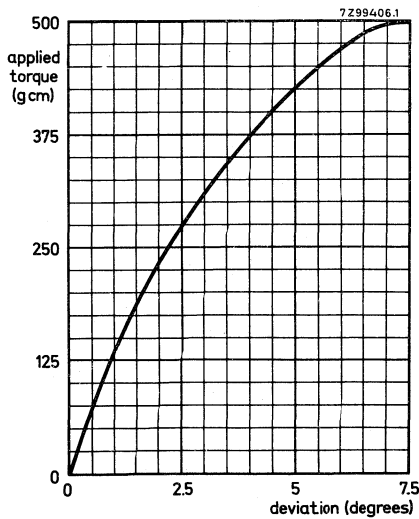

Fig. 4. Applied torque versus deviation.

STEPPER MOTORS

QUICK REFERENCE DATA	
Step angle	7° 30'
Maximum torque	1000 gcm *)
Holding torque	1400 gcm *)
Maximum pull-in rate	260 steps/s
Maximum pull-out rate	340 steps/s

70-657H4

RZ 26753 - 15

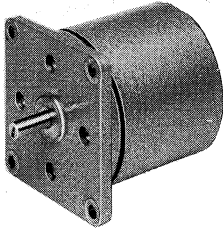

PD 18

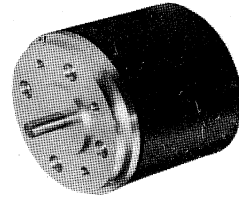

SMD 19

APPLICATION

These stepper motors have been designed for converting electrical digital information, supplied via an electronic switch, into mechanical movement. They can be used as positioners or in variable speed drives.

DESCRIPTION

The stepper motors have a 4-phase stator and a permanent magnet rotor with 24-poles, all enclosed in a robust aluminium housing. The motor coils are adapted to the electronic switch 9904 131 03003 (see relevant data sheet) for optimum performance. The PD18 has a square mounting flange while the SMD19 is provided with a so-called servo-flange (size 28) and meets standard servo-mount requirements. The motors are characterized by their robust design and if desired they can be made to satisfy MIL specifications.

*) 1 gcm = 10^{-4} Nm

TECHNICAL DATA

Dimensions

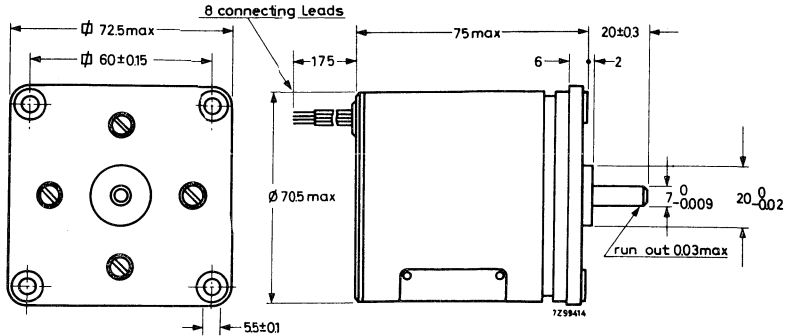

Fig. 1a.
PD 18
(in mm)

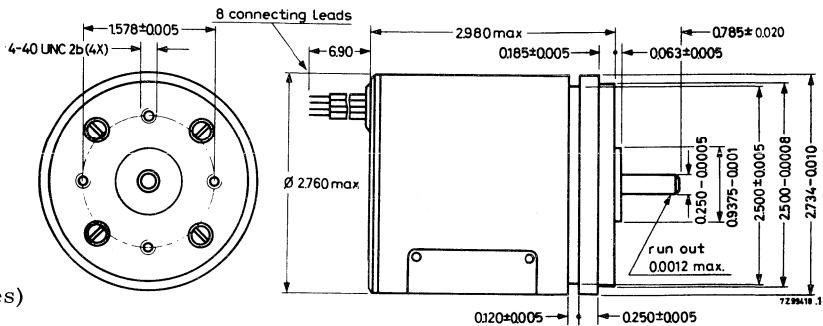

Fig. 1b.
SMD 19
(in inches)

Marking

The connecting leads are colour-coded, see Fig. 2.

Maximum pull-in torque	1000 gcm
Holding torque	1400 gcm
Maximum pull-in rate ¹⁾	260 steps/s
Maximum pull-out rate ¹⁾	340 steps/s
Number of steps per revolution	48
Step angle	7° 30'
Step angle tolerance	± 10' non cumulative
Direction of rotation	electrically reversible
Mass moment of inertia of the rotor	110 gcm ²

¹⁾ measured with 4-phase electronic switch 9904 131 03003 and with the coils connected according to Fig. 2b.

Maximum axial play (axial force 150 g)	0.07 mm
Maximum axial force	2000 g
Maximum radial force	5000 g
Bearings	ball
Weight	800 g
Ambient temperature range	
operating	-54 to +85 °C
storage	-62 to +110 °C
Maximum permissible motor temperature	125 °C
Number of phases	4
Resistance per coil	9 Ω
Inductance per coil	25 mH
Current per coil	600 mA
Power consumption of the motor	6.5 W
Insulation resistance at 500 V _{DC}	100 MΩ

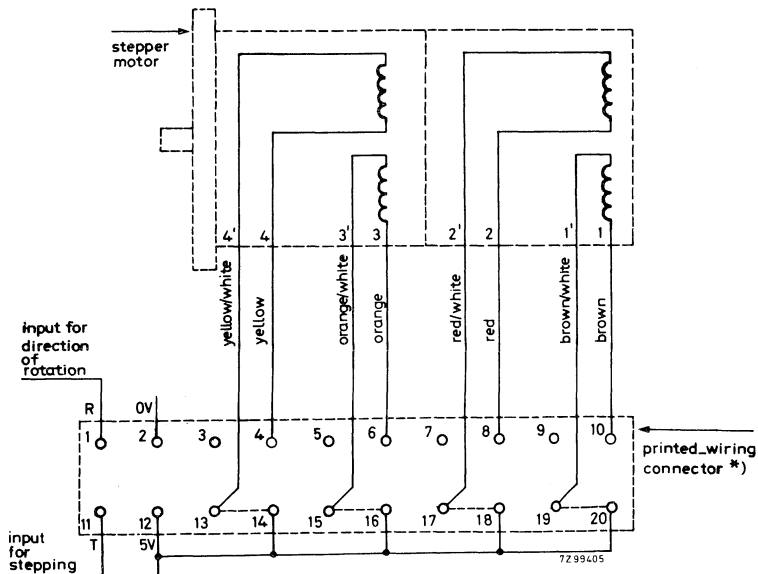

Fig. 2a. Diagram for connecting the motor to the electronic switch via a printed-wiring connector, without compensating network.

*) Figures refer to terminals of electronic switch.

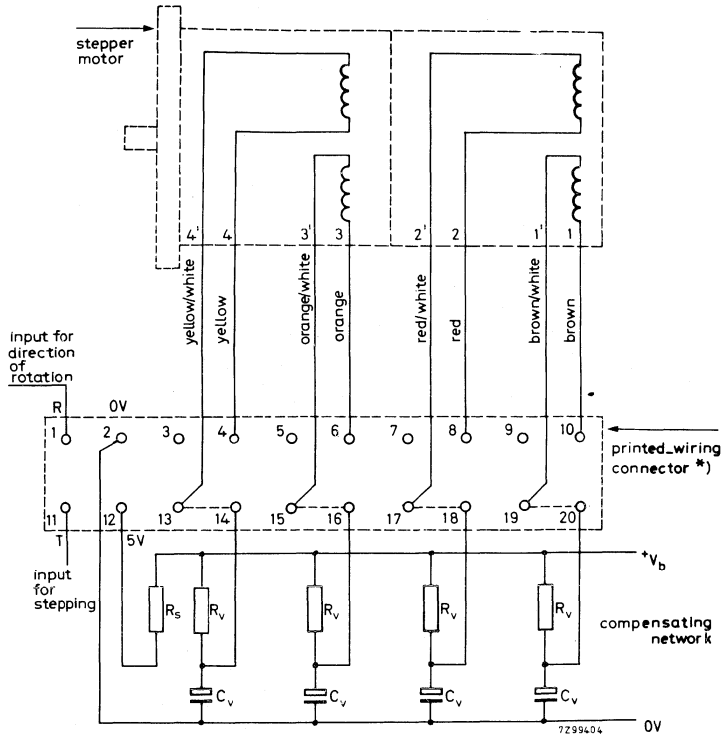

Fig. 2b. Diagram for connecting the motor to the electronic switch via a printed-wiring connector, with compensating network.

$$R_v = 10 \Omega (\pm 5\%), 8 W; C_v = 50 \mu F, 40 V d. c.; V_b = 12 V d. c.;$$

$$R_s = (V_b - 5)/0.230 \Omega$$

*) Figures refer to terminals of electronic switch.

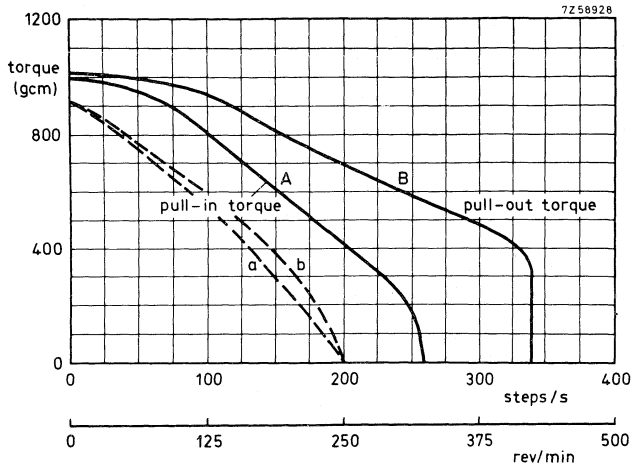

Fig. 3. Torque versus stepping rate, measured at room temperature. (Solid lines obtained with circuit of Fig. 2b, dashed lines obtained with circuit of Fig. 2a). Derating at low and high temperatures.

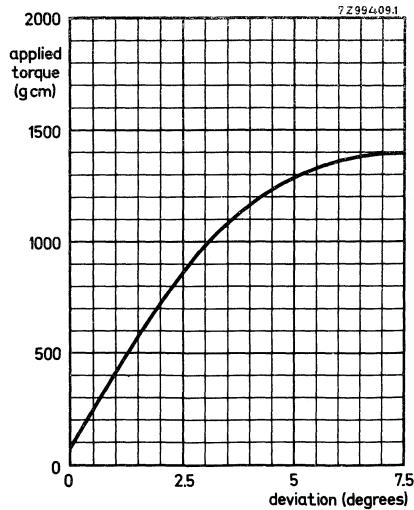
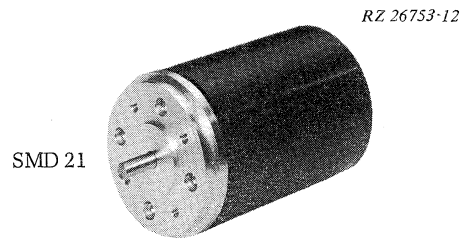
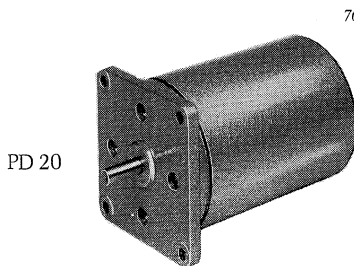

Fig. 4 Applied torque versus deviation

STEPPER MOTORS

QUICK REFERENCE DATA	
Step angle	3° 45'
Maximum torque	1600 gcm*)
Holding torque	1900 gcm*)
Maximum pull-in rate	650 steps/s
Maximum pull-out rate	6000 steps/s



APPLICATION

These stepper motors have been designed for converting electrical digital information, supplied via an electronic switch, into mechanical movement. They can be used as positioners or in variable speed drives.

DESCRIPTION

The stepper motors have an 8-phase stator and a permanent magnet rotor with 24 poles, all enclosed in a robust aluminium housing. The motor coils are adapted to the electronic switch 9904 131 03004 (see relevant data sheet) for optimum performance.

The PD20 has a square mounting flange while the SMD21 is provided with a so-called servo-flange (size 28) and meets standard servo-mount requirements. The motors are characterized by their robust design and if desired they can be made to satisfy MIL specifications.

*) 1 gcm = 10^{-4} Nm

TECHNICAL DATA

Dimensions

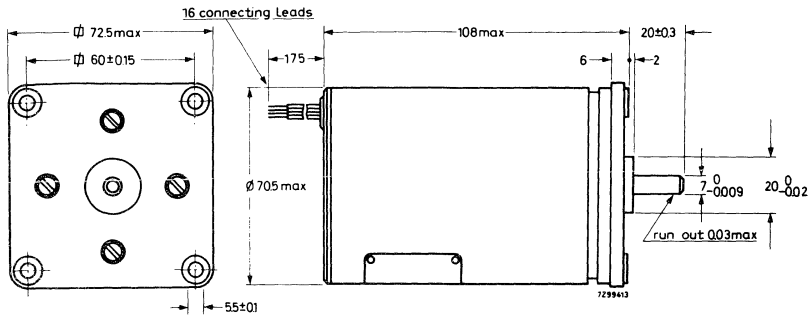

Fig. 1a. PD 20 (in mm)

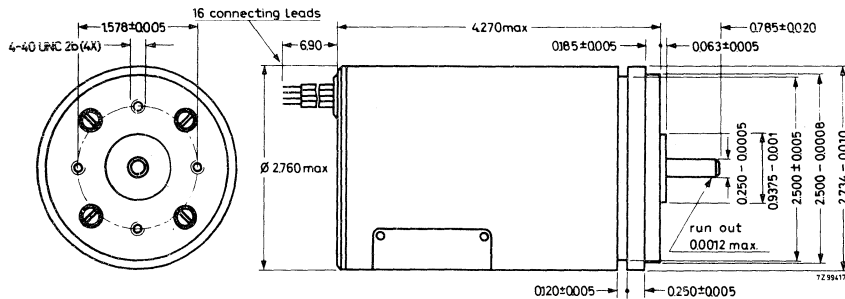

Fig. 1b. SMD 21 (in inches)

Marking

The connecting leads are colour-coded, see Fig. 2.

Maximum pull-in torque	1600 gcm
Holding torque	1900 gcm
Maximum pull-in rate ¹⁾	650 steps/s
Maximum pull-out rate ¹⁾	6000 steps/s
Number of steps per revolution	96
Step angle	3° 45'
Step angle tolerance	± 10' non cumulative
Direction of rotation	electrically reversible
Mass moment of inertia of the rotor	220 gcm ²
Maximum axial play (axial force 150 g)	0.07 mm
Maximum axial force	2000 g
Maximum radial force	5000 g
Bearings	ball
Weight	1400 g
Ambient temperature range	
operating	-54 to + 85 °C
storage	-62 to +110 °C
Maximum permissible motor temperature	125 °C
Number of phases	8
Resistance per coil	9 Ω
Inductance per coil	25 mH
Current per coil	550 mA
Power consumption of the motor	11 W
Insulation resistance at 500 V _{dc}	100 MΩ

¹⁾ measured with 8-phase electronic switch 9904 131 03004 and with the coils connected according to Fig. 2b.

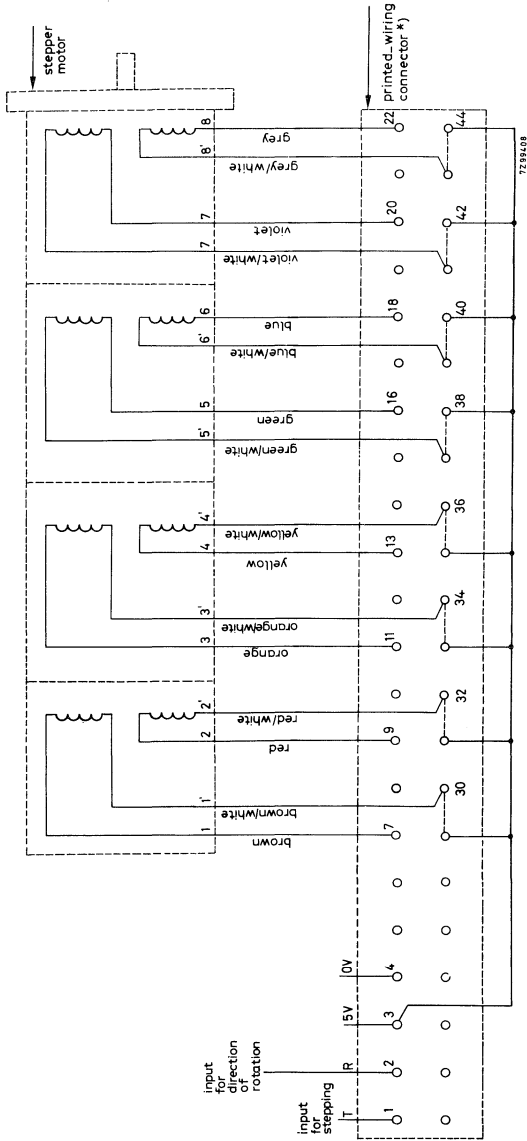

Fig. 2a. Diagram for connecting the motor to the electronic switch via a printed-wiring connector, without compensating network.

*) Figures refer to terminals of electronic switch.

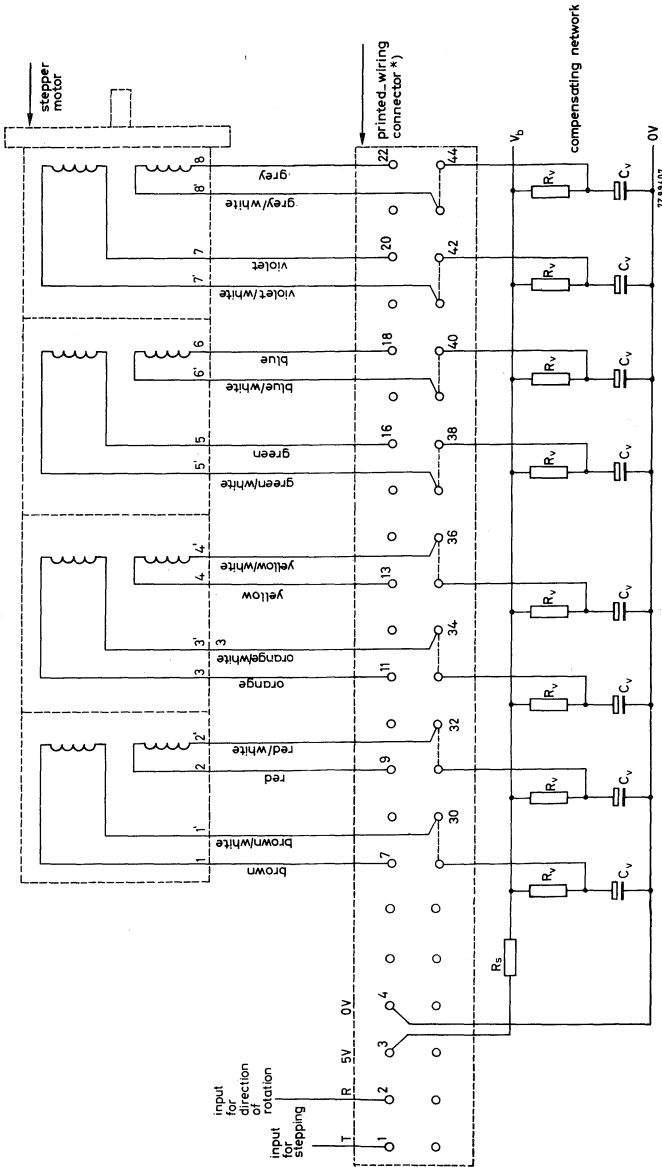

Fig.2b. Diagram for connecting the motor to the electronic switch via a printed-wiring connector, with compensating network.

$R_v = 30 \Omega$ ($\pm 5\%$), $16 W$; $C_v = 100 \mu F$, $64 V$ d.c.; $V_b = 20 V$ d.c.; $R_s = (V_b - 5)/0.440 \Omega$

*) Figures refer to terminals of electronic switch.



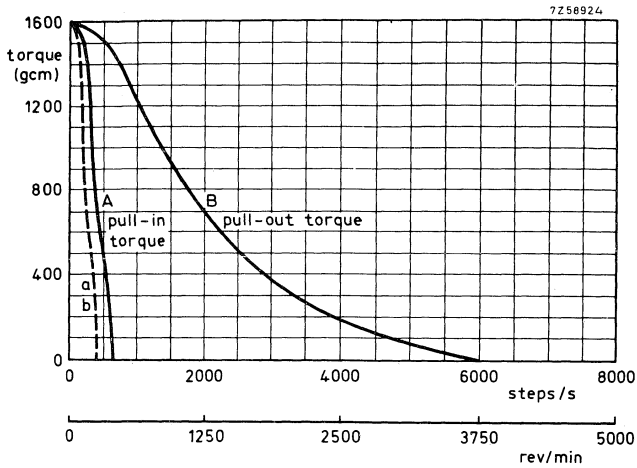

Fig. 3. Torque versus stepping rate, measured at room temperature. (Solid lines obtained with circuit of Fig. 2b, dashed lines obtained with circuit of Fig. 2a). Derating at low and high temperatures.

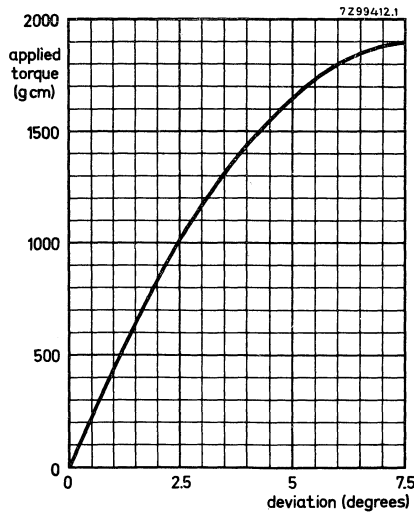

Fig. 4. Applied torque versus deviation.

STEPPER MOTORS

QUICK REFERENCE DATA	
Step angle	15°
Maximum torque	600 gcm*)
Holding torque	800 gcm*)
Maximum pull-in rate	140 steps/s
Maximum pull-out rate	460 steps/s

70-657H4

RZ 26753 - 15

PD 22

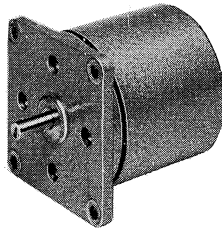

SMD 23

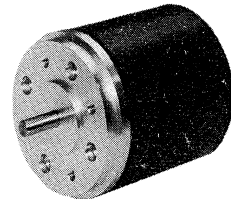

APPLICATION

These stepper motors have been designed for converting electrical digital information, supplied via an electronic switch, into mechanical movement. They can be used as positioners or in variable speed drives.

DESCRIPTION

The stepper motors have a 4-phase stator and a permanent magnet rotor with 12 poles, all enclosed in a robust aluminium housing. The motor coils are adapted to the electronic switch 9904 131 03003 (see relevant data sheet) for optimum performance.

The PD22 has a square mounting flange while the SMD23 is provided with a so-called servo-flange (size 28) and meets standard servo-mount requirements. The motors are characterized by their robust design and if desired they can be made to satisfy MIL specifications.

*) 1 gcm = 10^{-4} Nm

TECHNICAL DATA

Dimensions

Fig. 1a.
PD 22
(in mm)

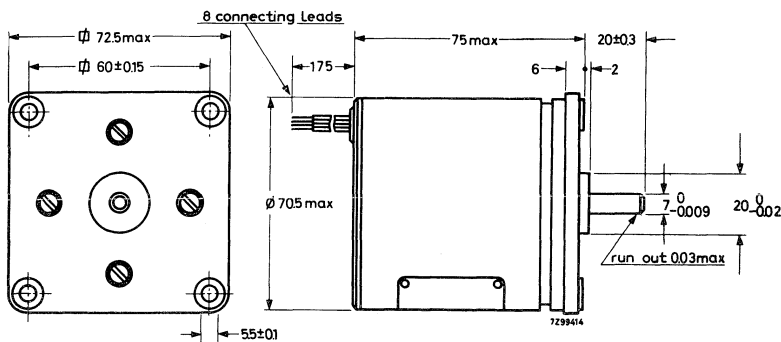
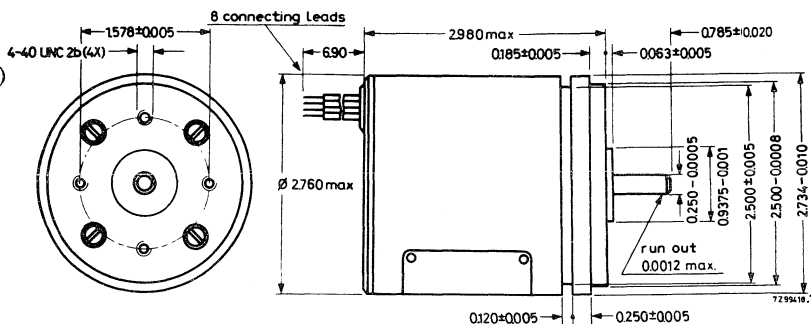

Fig. 1b.
SMD 23
(in inches)



Marking

The connecting leads are colour-coded, see Fig.2.

Maximum pull-out torque	600 gcm
Holding torque	800 gcm
Maximum pull-in rate ¹⁾	140 steps/s
Maximum pull-out rate ¹⁾	460 steps/s
Number of steps per revolution	24
Step angle	15°
Step angle tolerance	$\pm 15'$ non cumulative
Direction of rotation	electrically reversible
Mass moment of inertia of the rotor	110 gcm^2

¹⁾ measured with 4-phase electronic switch 9904 131 03003 and with the coils connected according to Fig.2b.

Maximum axial play (axial force 150 g)	0.07 mm
Maximum axial force	2000 g
Maximum radial force	5000 g
Bearings	ball
Weight	800 g
Ambient temperature range	
operating	-54 to + 85 °C
storage	-62 to +110 °C
Maximum permissible motor temperature	125 °C
Number of phases	4
Resistance per coil	9 Ω
Inductance per coil	20 mH
Current per coil	600 mA
Power consumption of the motor	6.5 W
Insulation resistance at 500 V _{dc}	100 MΩ

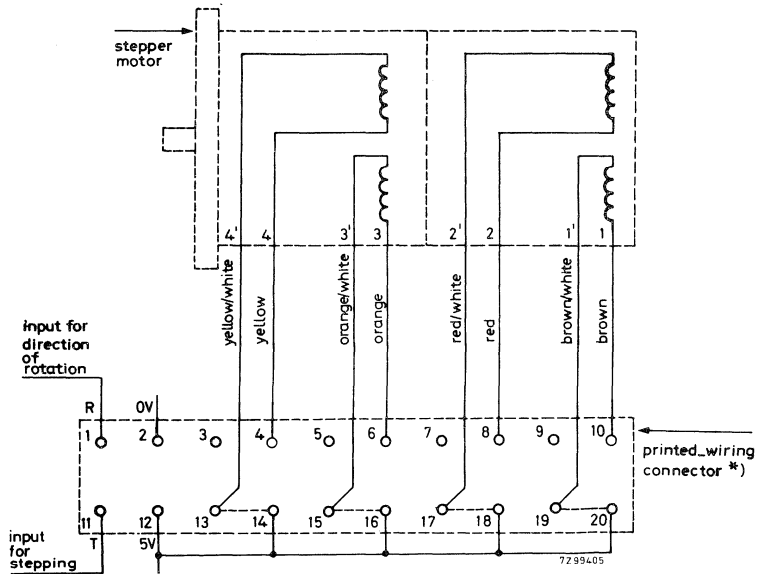

Fig. 2a. Diagram for connecting the motor to the electronic switch via a printed-wiring connector, without compensating network.

*) Figures refer to terminals of electronic switch.

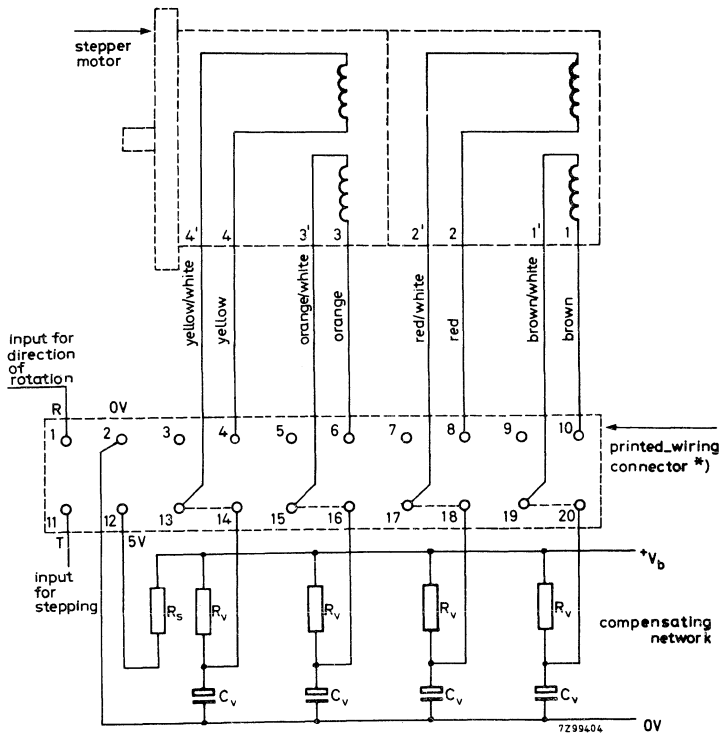

Fig. 2b. Diagram for connecting the motor to the electronic switch via a printed-wiring connector, with compensating network.

$$R_v = 10 \Omega (\pm 5\%), 8 \text{ W}; C_v = 50 \mu\text{F}, 40 \text{ V d.c.}; V_b = 12 \text{ V d.c.};$$

$$R_s = (V_b - 5)/0.230 \Omega$$

*) Figures refer to terminals of electronic switch.

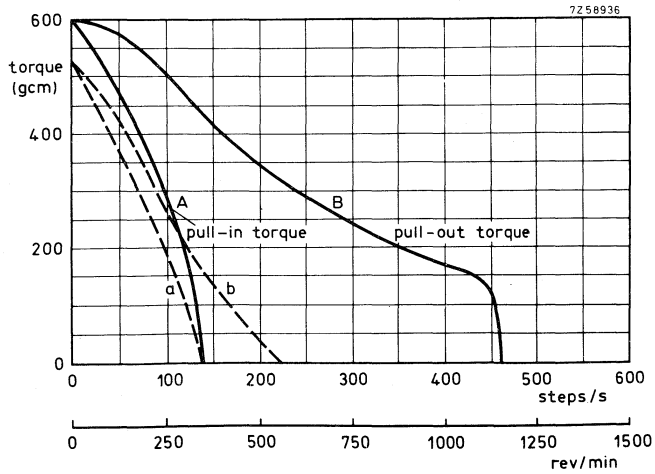

Fig. 3. Torque versus stepping rate, measured at room temperature. (Solid lines obtained with circuit of Fig. 2b, dashed lines obtained with circuit of Fig. 2a). Derating at low and high temperatures.

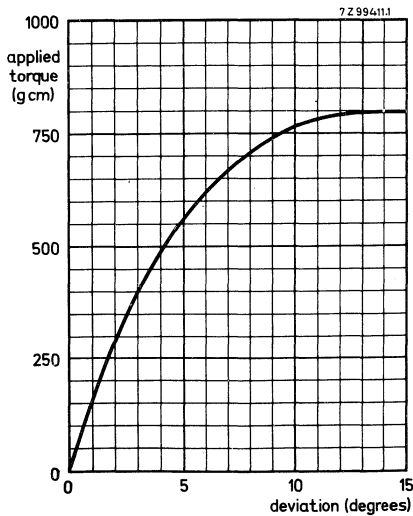

Fig. 4. Applied torque versus deviation.

STEPPER MOTORS

QUICK REFERENCE DATA	
Step angle	7° 30'
Maximum torque	900 gcm *)
Holding torque	1100 gcm *)
Maximum pull-in rate	350 steps/s
Maximum pull-out rate	3500 steps/s

70-657H1

RZ 26753 - 12

PD 24

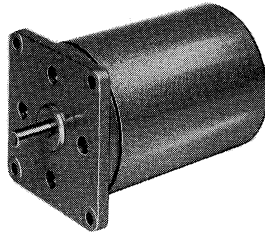

SMD 25

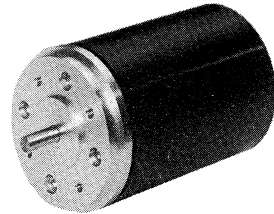

APPLICATION

These stepper motors have been designed for converting electrical digital information, supplied via an electronic switch, into mechanical movement. They can be used as positioners or in variable speed drives.

DESCRIPTION

The stepper motors have an 8-phase stator and a permanent magnet rotor with 12 poles, all enclosed in a robust aluminium housing. The motor coils are adapted to the electronic switch 9904 131 03004 (see relevant data-sheet) for optimum performance. The PD24 has a square mounting flange while the SMD25 is provided with a so-called servo-flange (size 28) and meets standard servo-mount requirements. The motors are characterized by their robust design and if desired they can be made to satisfy MIL specifications.

*) 1 gcm = 10⁻⁴ Nm

TECHNICAL DATA

Dimensions

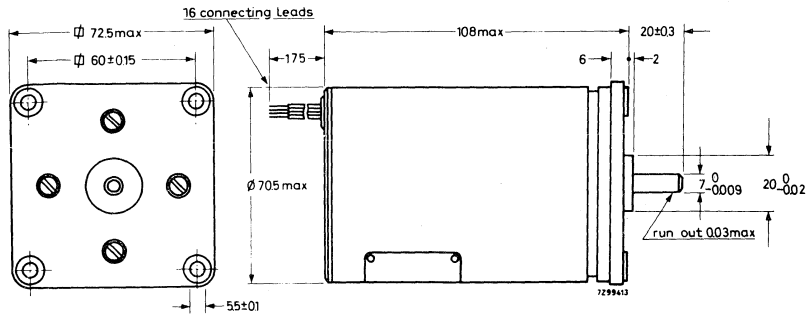

Fig. 1a. PD 24 (in mm)

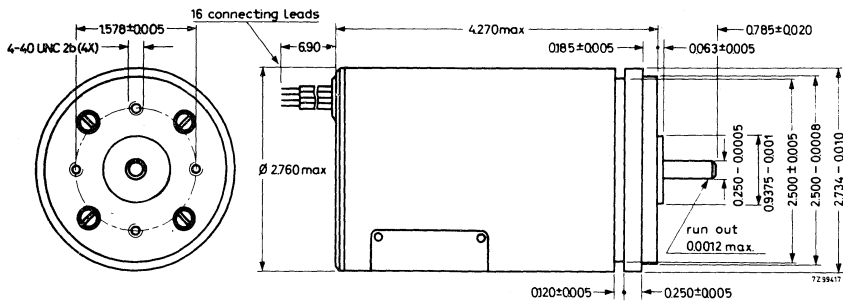

Fig. 1b. SMD 25 (in inches)

Marking

The connecting leads are colour-coded, see Fig. 2.

Maximum pull-in torque	900 gcm
Holding torque	1100 gcm
Maximum pull-in rate ¹⁾	350 steps/s
Maximum pull-out rate ¹⁾	3500 steps/s
Number of steps per revolution	48
Step angle	7° 30'
Step angle tolerance	±15' non cumulative
Direction of rotation	electrically reversible
Mass moment of inertia of the rotor	220 gcm ²
Maximum axial play (axial force 150 g)	0.07 mm
Maximum axial force	2000 g
Maximum radial force	5000 g
Bearings	ball
Weight	1400 g
Ambient temperature range	
operating	-54 to +85 °C
storage	-62 to +110 °C
Maximum permissible motor temperature	125 °C
Number of phases	8
Resistance per coil	9 Ω
Inductance per coil	20 mH
Current per coil	550 mA
Power consumption of the motor	11 W
Insulation resistance at 500 V _{dc}	100 MΩ

¹⁾ measured with 8-phase electronic switch 9904 131 03004 and with the coils connected according to Fig.2b.

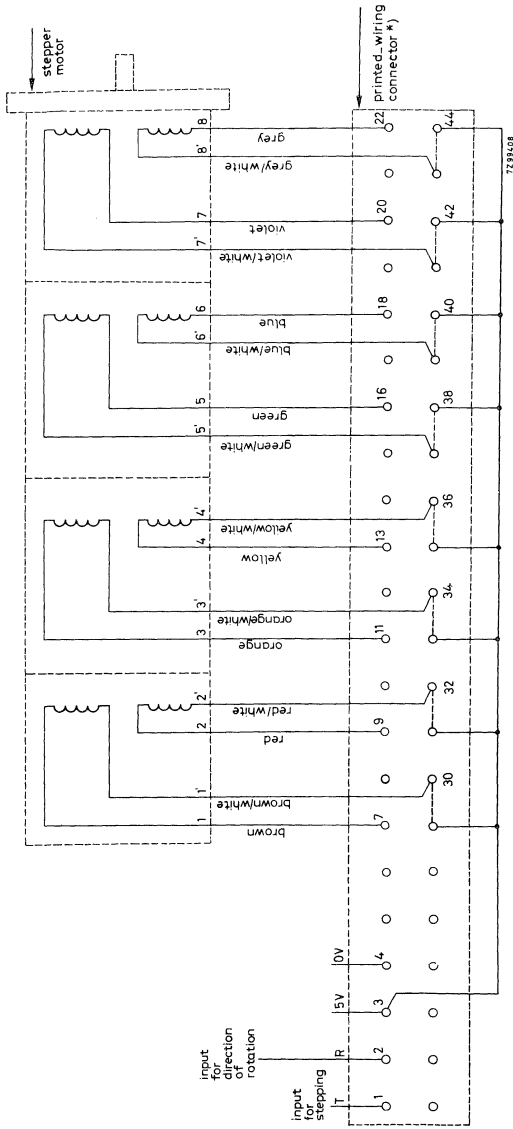

Fig. 2a. Diagram for connecting the motor to the electronic switch via a printed-wiring connector, without compensating network.

*) Figures refer to terminals of electronic switch.

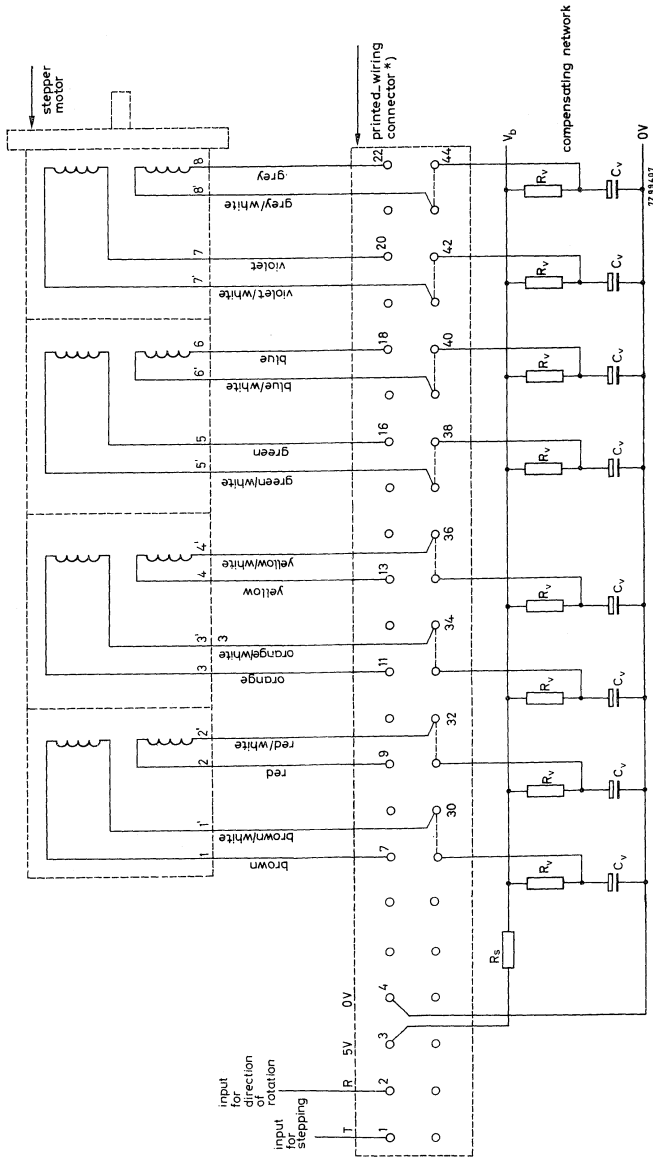

Fig. 2b. Diagram for connecting the motor to the electronic switch via a printed-wiring connector, with compensating network.

$R_v = 30 \Omega$ ($\pm 5\%$), $16 W$; $C_v = 100 \mu F$, $64 V$ d.c.; $V_b = 20 V$ d.c.; $R_s = (V_b - 5)/0.440 \Omega$.

*) Figures refer to terminals of electronic switch.



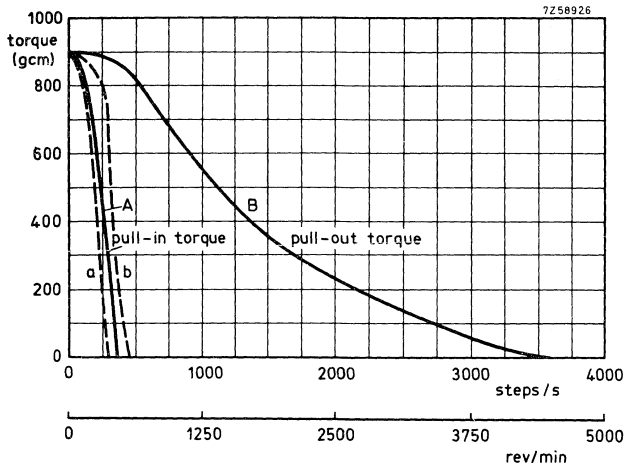

Fig. 3. Torque versus stepping rate, measured at room temperature. (Solid lines obtained with circuit of Fig. 2b, dashed lines obtained with circuit of Fig. 2a). Derating at low and high temperatures.

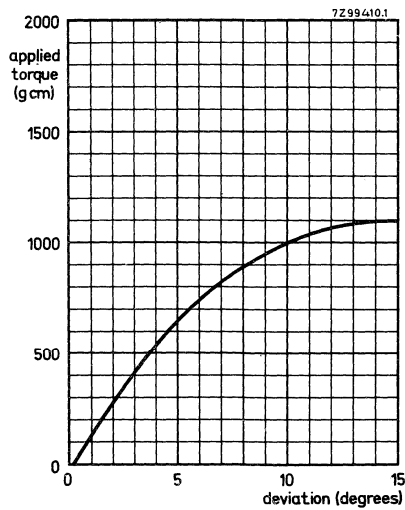
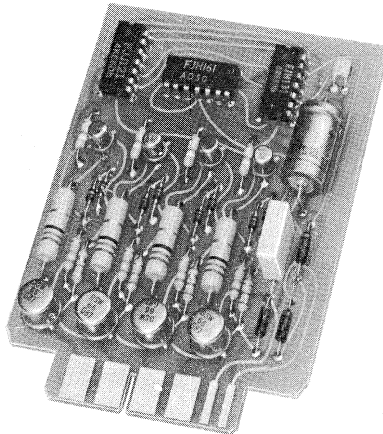

Fig. 4 Applied torque versus deviation.

ELECTRONIC SWITCH for 4-phase stepper motors



RZ 26753-1

APPLICATION

The electronic switch changes a train of input pulses into a sequential pulse output which provides the required pulse pattern for driving 4-phase stepper motors.

DESCRIPTION

The electronic switch is essentially a reversible ring counter, each of its 4 outputs being followed by an output stage. The ring counter is built up with I.C.'s of the FJ series which need a supply voltage of 5 V. For this reason the whole unit has been designed for this voltage. The unit has two inputs: the first one receives the order for the rotor to perform the step, the second one determines the direction of rotation by means of a d.c. level. The output stages are equipped with silicon transistors developed for switching inductive loads. All components are mounted on a double-sided printed-wiring board mating a printed-wiring connector with two rows of 10 contacts and a contact pitch of 0.156 inch.

TECHNICAL DATA

Dimensions (in mm and in inches) and terminal location

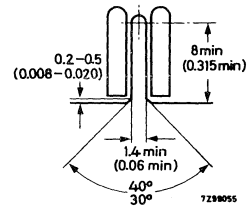
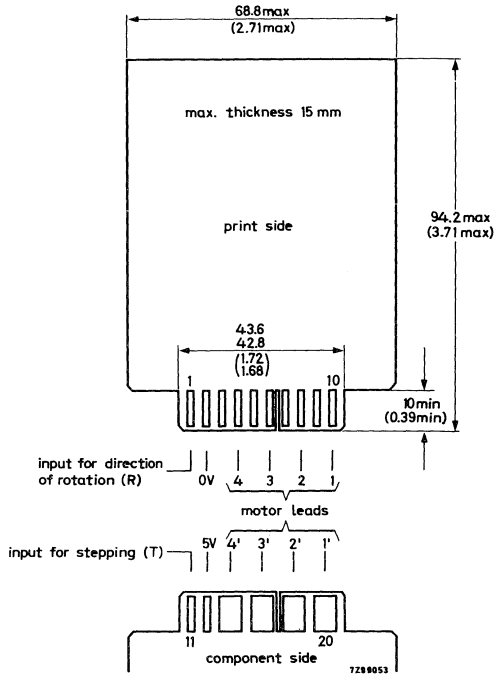

Detailed view of the slot

Weight 40 g

Ambient temperature range

operating 0 to +70 °C
storage -40 to +70 °C

Power supply

voltage (V_b) +5 V ± 5%
current (at V_b = 5 V) 230 mA ± 10%

Input dataDirection of rotation

V_R in "1" state (high level)	$\geq 2.0 \text{ V}, \leq 5 \text{ V}$	} see Note below
V_R in "0" state (low level)	$\leq 0.8 \text{ V}, \geq 0 \text{ V}$	
I_R (V_R in "1" state)	$< 120 \mu\text{A}$	
$-I_R$ (V_R in "0" state)	$< 4.8 \text{ mA}$	
Maximum V_R	5.5 V	
$-I_R$, limiting value	20 mA	

Stepping

V_T in "1" state (high level)	$\geq 2.0 \text{ V}, \leq 5 \text{ V}$
V_T in "0" state (low level)	$\leq 0.8 \text{ V}, \geq 0 \text{ V}$
I_T (V_T in "1" state)	$< 250 \mu\text{A}$
$-I_T$ (V_T in "0" state)	$< 6.4 \text{ mA}$
Maximum V_T	5.5 V
$-I_T$, limiting value	20 mA
Pulse width (V_T in "1" state)	$> 100 \text{ ns}$
Frequency	$< 25 \text{ kHz}$

Output data

Permissible voltage (at each output)	$< 100 \text{ V}$
Permissible current (per output)	$< 600 \text{ mA}$
Saturation voltage (V_{CE})	$< 500 \text{ mV}$

Note: The level may change state only when the input pulse for stepping is in the "0" state (low level).

Circuit diagram

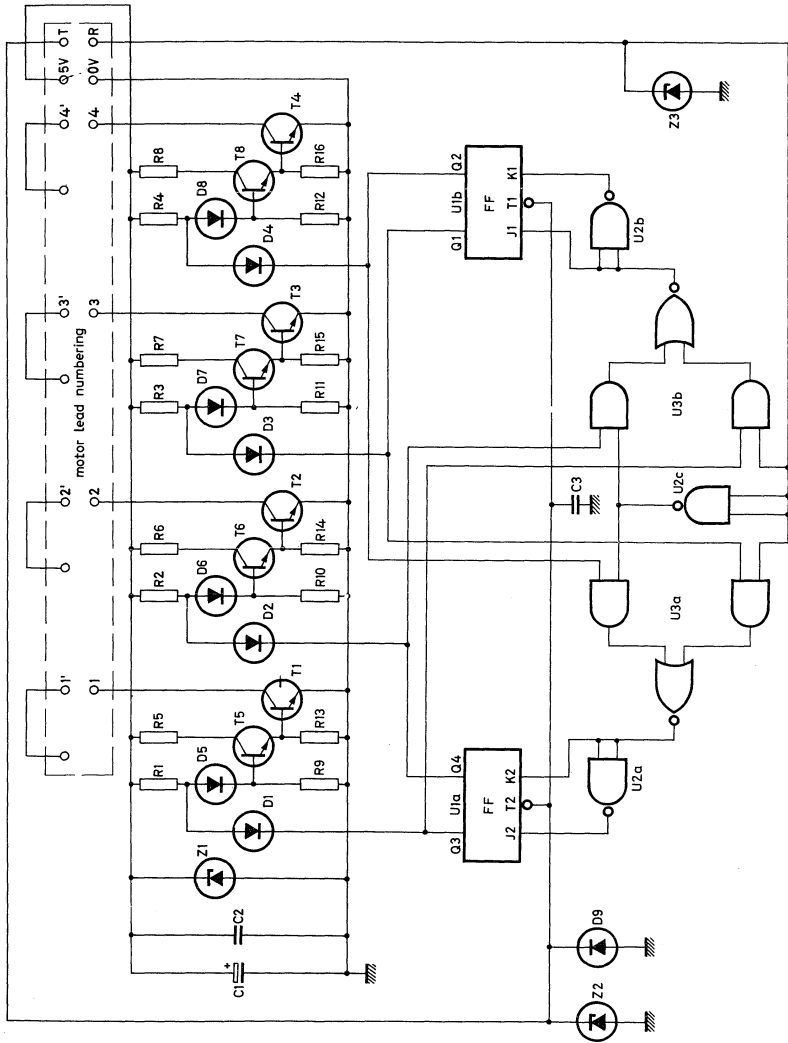

Parts list

component	description	value	tolerance
C1	electrolytic capacitor	125 μ F, 10 V	-10/+50%
C2	capacitor	0.1 μ F	10%
C3	capacitor	1 nF	10%
D1 -D8	diode	BAX13	
D9	diode	AAZ18	
U1	integrated circuit	FJJ121	
U2	integrated circuit	FJH131	
U3	integrated circuit	FJH161	
R1 -R4	carbon resistor	390 Ω , 0.2 W	5%
R5 -R8	carbon resistor	51 Ω , 0.7 W	5%
R9 -R12	carbon resistor	6.8 k Ω , 0.2 W	5%
R13-R16	carbon resistor	180 Ω , 0.2 W	5%
T1 -T4	transistor	BSW66	
T5 -T8	transistor	BC107	
Z1	zener diode	BZY88/C5V6	
Z2 -Z3	zener diode	BZY88/C5V1	

ELECTRONIC SWITCH for 8-phase stepper motors

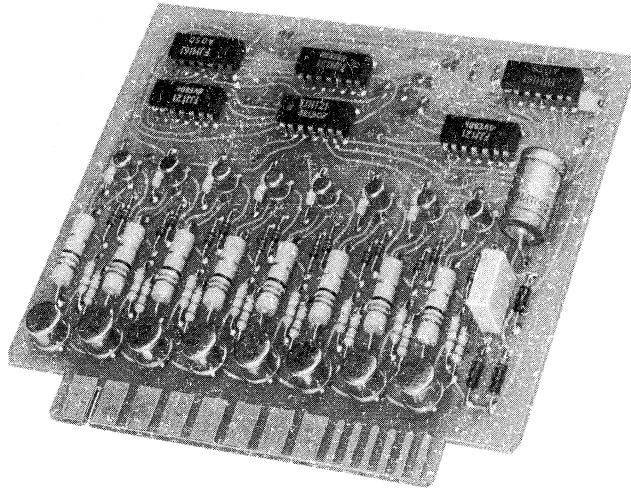

RZ 26753-2

APPLICATION

The electronic switch changes a train of input pulses into a sequential pulse output which provides the required pulse pattern for driving 8-phase stepper motors.

DESCRIPTION

The electronic switch is essentially a reversible ring counter, each of its 8 outputs being followed by an output stage. The ring counter is built up with I.C.'s of the FJ series which need a supply voltage of 5 V. For this reason the whole unit has been designed for this voltage. The unit has two inputs: the first one receives the order for the rotor to perform the step, the second one determines the direction of rotation by means of a d. c. level. The output stages are equipped with silicon transistors developed for switching inductive loads. All components are mounted on a double-sided printed-wiring board mating a printed-wiring connector with two rows of 22 contacts and a contact pitch of 0.156 inch.

TECHNICAL DATA

Dimensions (in mm and in inches) and terminal location

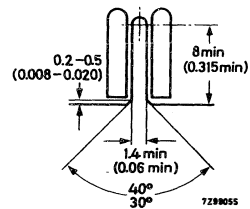
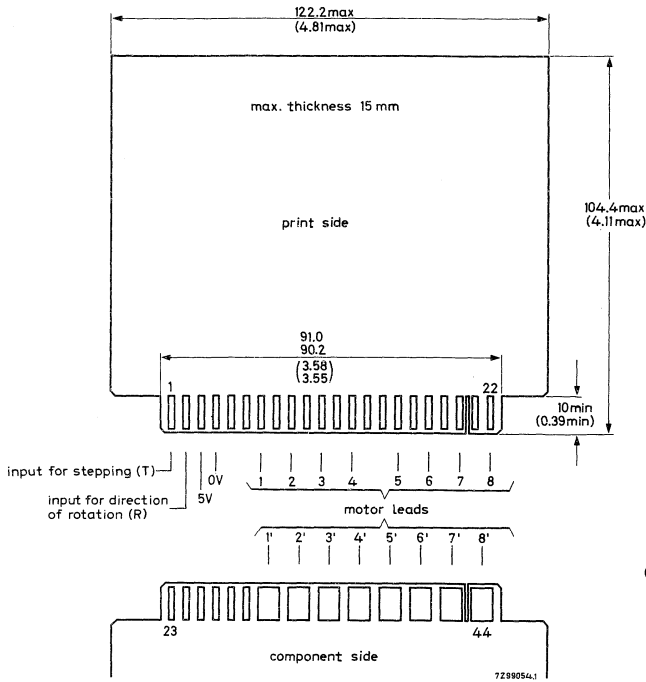

Detailed view of the slot

Weight 80 g

Ambient temperature range

operating 0 to +70 °C

storage -40 to +70 °C

Power supply

voltage (V_b) +5 V \pm 5%

current (at $V_b = 5$ V) 440 mA \pm 10%

Input dataDirection of rotation

V_R in "1" state (high level)	$\geq 2.0 \text{ V}, \leq 5 \text{ V}$	} see Note below
V_R in "0" state (low level)	$\leq 0.8 \text{ V}, \geq 0 \text{ V}$	
I_R (V_R in "1" state)	$< 200 \mu\text{A}$	
$-I_R$ (V_R in "0" state)	$< 8 \text{ mA}$	
Maximum V_R	5.5 V	
$-I_R$, limiting value	20 mA	

Stepping

V_T in "1" state (high level)	$\geq 2.0 \text{ V}, \leq 5 \text{ V}$
V_T in "0" state (low level)	$\leq 0.8 \text{ V}, \geq 0 \text{ V}$
I_T (V_T in "1" state)	$< 400 \mu\text{A}$
$-I_T$ (V_T in "0" state)	$< 12.8 \text{ mA}$
Maximum V_T	5.5 V
$-I_T$, limiting value	20 mA
Pulse width (V_T in "1" state)	$> 100 \text{ ns}$
Frequency	$< 25 \text{ kHz}$

Output data

Permissible voltage (at each output)	$< 100 \text{ V}$
Permissible current (per output)	$< 600 \text{ mA}$
Saturation voltage (V_{CE})	$< 500 \text{ mV}$

Note: The level may change state only when the input pulse for stepping is in the "0" state (low level).

Circuit diagram

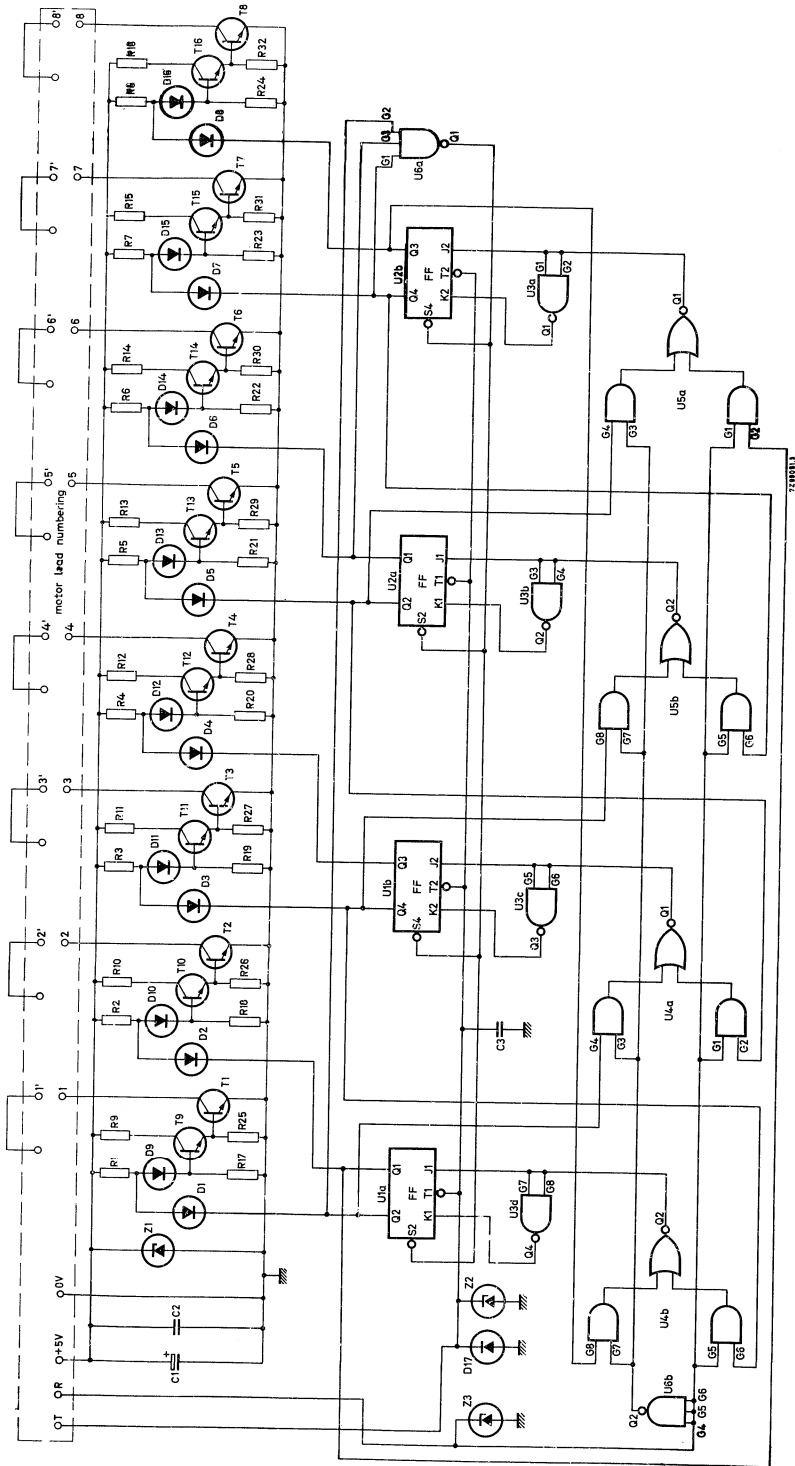

Parts list

component	description	value	tolerance
C1	electrolytic capacitor	125 μ F, 10 V	-10/+50%
C2	capacitor	0.1 μ F	10%
C3	capacitor	1 nF	10%
D1 -D16	diode	BAX13	
D17	diode	AAZ18	
U1	integrated circuit	FJJ121	
U2	integrated circuit	FJJ121	
U3	integrated circuit	FJH131	
U4	integrated circuit	FJH161	
U5	integrated circuit	FJH161	
U6	integrated circuit	FJH121	
R1 -R8	carbon resistor	390 Ω , 0.2 W	5%
R9 -R16	carbon resistor	51 Ω , 0.7 W	5%
R17-R24	carbon resistor	6.8 k Ω , 0.2 W	5%
R25-R32	carbon resistor	180 Ω , 0.2 W	5%
T1 -T8	transistor	BSW66	
T9 -T16	transistor	BC107	
Z1	zener diode	BZY88/C5V6	
Z2 -Z3	zener diode	BZY88/C5V1	

Small d.c. motors



Governed d.c. motors page C3

Ungoverned d.c. motors page C27

APPLICATIONS

The governed d.c. motors have been developed for use with an electronic speed control unit to keep the speed of the motor within narrow limits under variations in load, supply and temperature. Sample electronic control units or circuit diagrams are available on request.

The motors can be used in a wide range of applications.

Recording instruments:

- cassette recorders
- portable tape recorders
- record players and changers
- chart and pen-driving units in recording instruments

Optical industry:

- film cameras (film drive and zoom lens drive)
- slide projectors

Measurement and control equipment:

- small battery timers
- domestic clocks

Instruments for automation

DIRECT CURRENT MOTOR in deep drawn metal housing

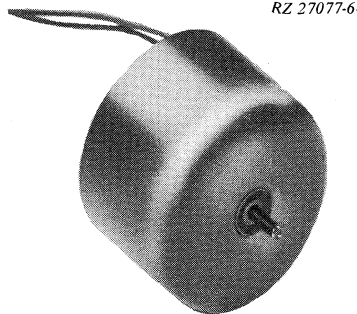

RZ 27077-6

QUICK REFERENCE DATA

Nominal voltage	4.5 V _{dc}
Speed	2000 rev/min
Input power	max. 0.6 W
Torque	min. 11 gcm *)

APPLICATION

This small d. c. motor has been designed for applications which require a high quality.

Examples:

- small tape recorders (cassette recorders)
- record players
- record changers
- film cameras
- car cassette radios

DESCRIPTION

The motor has been provided with a permanent magnet system, consisting of a ring magnet with which a very low holding torque has been obtained. It has a nickel-plated deep drawn steel housing. The built-in spark suppressor (V.D.R.) increases the collector life considerably.

The motor is suitable for operation in tropical environments.

*) 1 gcm = 10^{-4} Nm

TECHNICAL DATA

Dimensions in mm

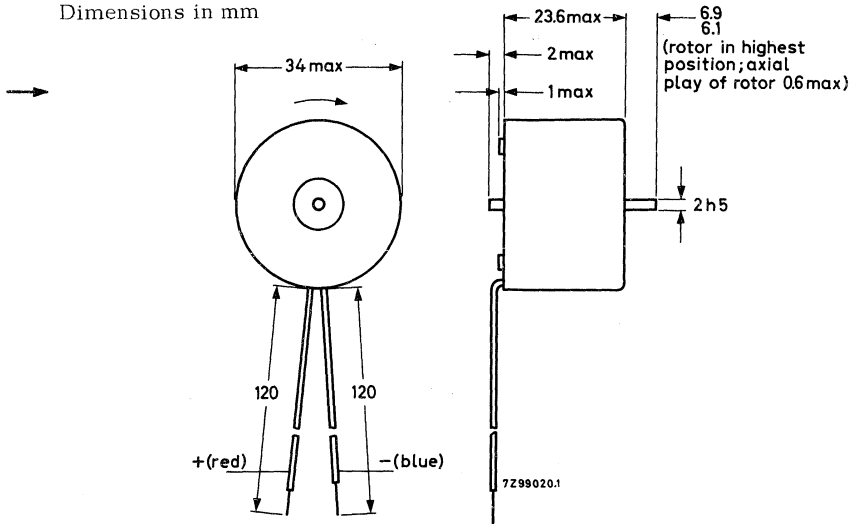

Weight

100 g

The values given below apply to an ambient temperature of 22 ± 5 °C, an atmospheric pressure of 860-1060 mbar and a relative humidity of 45-75%.

Nominal values

Voltage	4.5 V _{dc}
Torque	min. 11 gcm *)
Speed	
at nominal load	2000 rev/min
at no load	2650 ± 250 rev/min
Current	
at nominal load	max. 0.110 A
at no load	max. 0.035 A
Starting torque	min. 50 gcm *)
Input power	max. 0.6 W
Induced voltage at 3000 rev/min	4.4-5.1 V
Rotor resistance measured statically with brushes	$10 \pm 0.7 \Omega$
Direction of rotation	clockwise, see dimensional drawing
Ambient temperature range	-10 to +50 °C
Bearings	slide-bearings
Maximum radial force on the bearings	100 g *)

$$*) 1 \text{ gcm} = 10^{-4} \text{ Nm}$$

$$1 \text{ g} = 10^{-2} \text{ N}$$

Maximum axial force	10 g *)
Maximum axial play	0.6 mm
Rotor inertia	$10.2 \times 10^{-3} \text{ gcms}^2$ *)
Housing, material	steel, deep drawn
finish	nickel-plated

Limiting conditions

The following maximum values should never be exceeded.

Maximum voltage	6 V _{dc}
Maximum permissible load	18 gcm *)
Maximum permissible input current	0.15 A
Maximum speed	3000 rev/min
Maximum output	0.5 W

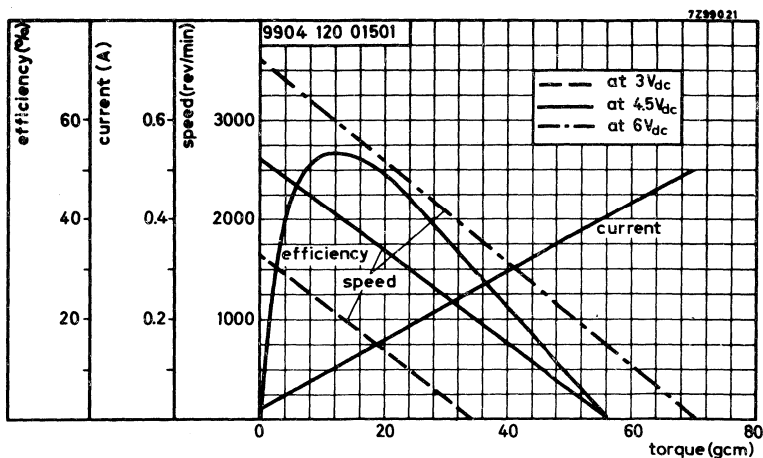

The curves are measured on an arbitrary motor.

REMARK

The motor can be used with the electronic speed control unit 9904 132 01006; see the relevant data sheet.

*) 1 gcm = 10^{-4} Nm
1 g = 10^{-2} N

DIRECT CURRENT MOTOR with interference-suppression filter

RZ 27077-21

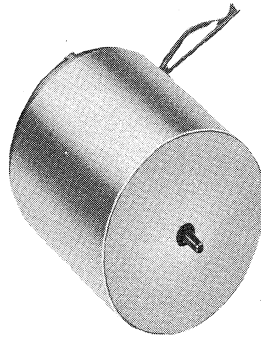

QUICK REFERENCE DATA

Nominal voltage		4.5 V _{dc}
Speed		2000 rev/min
Input power	max.	0.6 W
Torque	min.	11 gcm *)

APPLICATION

This small d.c. motor has been designed for applications which require a high quality, e.g. musical equipment.

DESCRIPTION

The motor has been provided with a permanent magnet system, consisting of a ring magnet with which a very low holding torque has been obtained. It has a housing of extruded aluminium. The built-in spark suppressor (V.D.R.) increases the collector life considerably. An interference-suppression filter has been incorporated in the housing so that there can be no objection to building in this type of motor close to equipment that is sensitive to electrical interference.

The motor is suitable for operation in tropical environments.

*) 1 gcm = 10^{-4} Nm

TECHNICAL DATA

Dimensions in mm

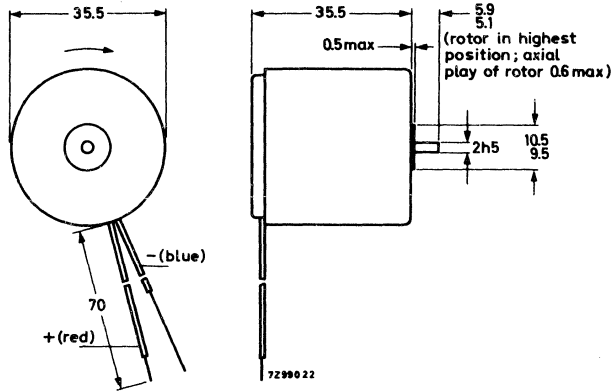

Weight

100 g

The values given below apply to an ambient temperature of 22 ± 5 °C, an atmospheric pressure of 860-1060 mbar and a relative humidity of 45-75%.

Nominal values

Voltage

4.5 V_{dc}

Torque

min. 11 gcm *)

Speed

at nominal load

2000 rev/min

at no load

2650 \pm 250 rev/min

Current

at nominal load

max. 0.110 A

at no load

max. 0.035 A

Starting torque

min. 50 gcm *)

Input power

max. 0.6 W

Induced voltage at 3000 rev/min

4.4 - 5.1 V

Rotor resistance measured statically

with brushes

$10 \pm 0.7 \Omega$

Direction of rotation

clockwise, see dimensional drawing

Ambient temperature range

-10 to +50 °C

Bearings

slide bearings

Maximum radial force on the bearings

100 g *)

Maximum axial force

10 g *)

Maximum axial play

0.6 mm

Rotor inertia

$10.2 \times 10^{-3} \text{ gcm}^2$ *)

Housing, material

aluminium; extruded

*) 1 gcm = 10^{-4} Nm
1 g = 10^{-2} N

Limiting conditions

The following maximum values should never be exceeded.

Maximum voltage	6 V _{dc}
Maximum permissible load	18 gcm *)
Maximum permissible input current	0.15 A
Maximum speed	3000 rev/min
Maximum output	0.5 W

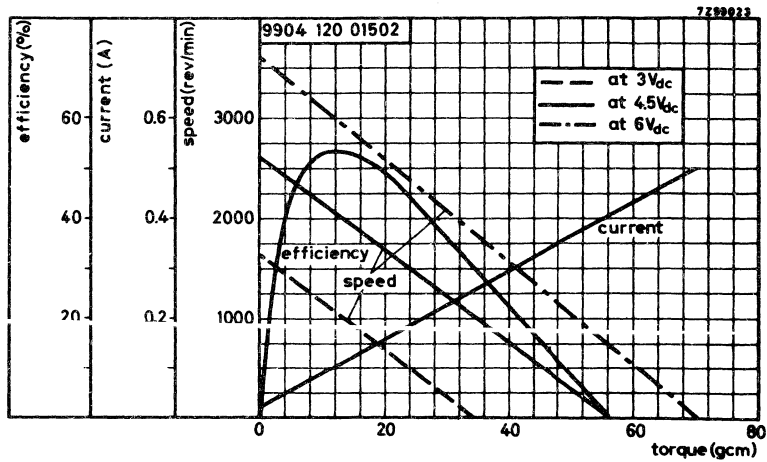

The curves are measured on an arbitrary motor.

REMARK

The motor can be used with the electronic speed control unit 9904 132 01006; see the relevant data sheet.

*) 1 gcm = 10^{-4} Nm

DIRECT CURRENT MOTOR

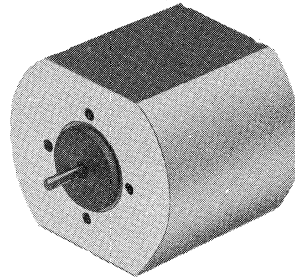

QUICK REFERENCE DATA

Nominal voltage	3.2	V _{dc}
Speed	2000	rev/min
Input power	max. 0.85	W
Torque	min. 18	gcm [*])

APPLICATION

This small d.c. motor has been mainly designed for servo purposes in a wide range of professional and industrial applications. ←

Examples:

- film cameras (film drive and zoom lens drive)
- slide projectors
- portable recording instruments (chart drive and pen drive)
- instruments for automation.

DESCRIPTION

The motor has been provided with a housing of sintered iron.

A special construction of a flat collector, a light brush construction and a built-in spark suppressor (V.D.R.) guarantee a smooth running.

The motor is suitable for tropical environments.

^{*}) 1 gcm = 10⁻⁴ Nm

TECHNICAL DATA

Dimensions in mm

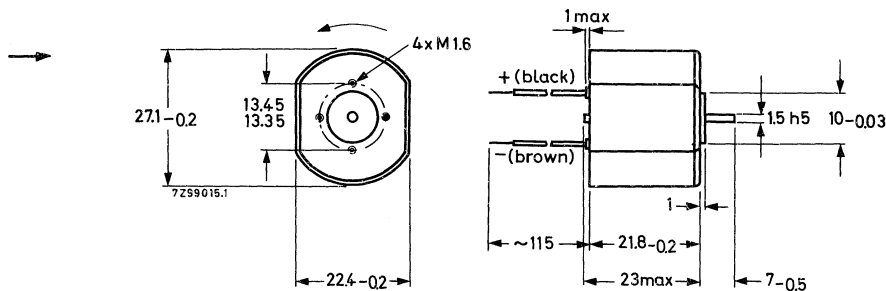

Weight

approx. 45 g

The values given below apply to an ambient temperature of 22 ± 5 °C, an atmospheric pressure of 860-1060 mbar and a relative humidity of 45-75%.

Nominal values

Voltage	3.2 V _{dc}
Torque	min. 18 gcm *)
Speed	
at nominal load	2000 rev/min
at no load	3000-3500 rev/min
Current	
at nominal load	max. 0.265 A
at no load	max. 0.05 A
Starting voltage at no load	max. 0.6 V _{dc}
Starting torque	min. 45 gcm *)
Input power	max. 0.85 W
Induced voltage at 3000 rev/min	2.6-3.1 V
Rotor resistance measured statically with brushes	4.5 Ω ± 10%
Direction of rotation	counterclockwise, see dimensional drawing
Ambient temperature range	-10 to +50 °C
Bearings	slide bearings; self-lubricating
Maximum radial force on the bearings	100 g *)
Maximum axial force	10 g *)
Maximum axial play	0.4 mm
Rotor inertia	4.10 ⁻³ gcms ² *)
Housing, material	sintered iron
finish	blackened

*) 1 gcm = 10⁻⁴ Nm1 g = 10⁻² N

Limiting conditions

The following maximum values should never be exceeded.

Maximum voltage	5 V _{dc}
Maximum permissible load	25 gcm *)
Maximum permissible input current	0.35 A
Maximum speed	3500 rev/min
Maximum output	0.8 W

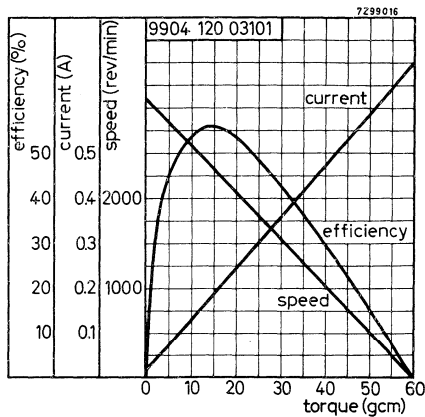

The curves are measured on an arbitrary motor.

REMARKS

- A circuit diagram of an electronic speed control, suitable for this motor, can be supplied on request.
- Special long-life versions for use in e. g. small recorders are available on request.

*) 1 gcm = 10^{-4} Nm

DIRECT CURRENT MOTORS with reduction

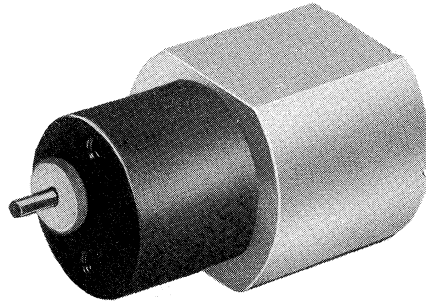

QUICK REFERENCE DATA

catalogue number	nominal voltage (V _{dc})	reduction ratio	speed (rev/min)	input power (W)	torque (gcm *)
9904 120 53101	3	27 : 1	96	0.45	150
9904 120 53102	3	15.8 : 1	162	0.45	90
9904 120 53103	3	10 : 1	258	0.45	55
9904 120 53104	3	1.6 : 1	1600	0.45	11

APPLICATION

These small d.c. motors with reduction have been mainly designed for servo purposes in professional and industrial applications, which require high reliability and smooth running.

Examples:

- film cameras (film drive and zoom lens drive)
- slide projectors
- portable recording instruments (chart drive and pen drive)
- instruments for automation.

*) 1 gcm $\approx 10^{-4}$ Nm

DESCRIPTION

The motors have been provided with a housing of sintered iron. A reduction of the motor speed has been obtained by means of a high-precision reduction gear, mounted in a steel housing, which is fitted to the motor. A special construction of a flat collector, a light brush construction and a built-in spark suppressor (V.D.R.) guarantee a smooth running. The motors are suitable for use with an electronic remote control unit. They can be used in tropical environments.

TECHNICAL DATA

Dimensions in mm

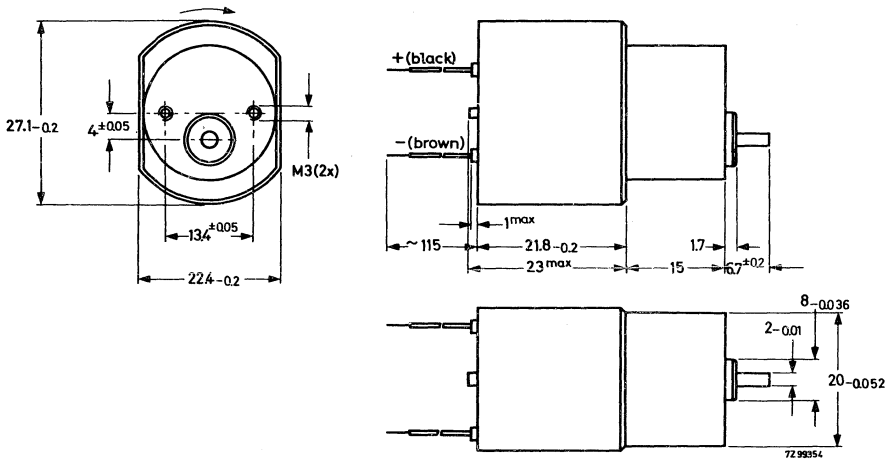

The direction of rotation is given in connection with the polarity.

Weight approx. 65 g

The values given below apply to an ambient temperature of $22 \pm 5^\circ\text{C}$, an atmospheric pressure of 860 - 1060 mbar and a relative humidity of 45 - 75%.

Nominal values

Catalogue number 9904 120	53101	53102	53103	53104	
Reduction ratio	27 : 1	15.8 : 1	10 : 1	1.6 : 1	
Voltage	3	3	3	3	V_{dc}
Torque	150	90	55	11	gcm *)
Speed at nominal load	96 ± 12	162 ± 20	258 ± 31	1600 ± 180	rev/min
at no load	110 ± 12	190 ± 20	298 ± 31	1870 ± 200	rev/min
Current at nominal load	≤ 0.15	≤ 0.15	≤ 0.15	≤ 0.15	A
at no load	≤ 0.05	≤ 0.05	≤ 0.05	≤ 0.05	A
Starting voltage at no load	< 1	< 1	< 1	< 1	V_{dc}
Starting torque	≥ 750	≥ 450	≥ 285	≥ 55	gcm *)
Input power	≤ 0.45	≤ 0.45	≤ 0.45	≤ 0.45	W
Maximum radial force on the bearings	200	200	200	100	g *)

Induced voltage at 3000 rev/min (rotor speed)	between 2.6 and 3.1 V
Rotor resistance measured statically with brushes	$4.5 \Omega \pm 10\%$
Direction of rotation	clockwise, see dimensional drawing
Ambient temperature range	-10 to $+50^\circ\text{C}$
Maximum axial force	100 g *)
Maximum axial play	0.2 mm
Rotor inertia	$4 \cdot 10^{-3} \text{ gcm}^2$
Housing, material of motor	sintered iron
material of gearbox	steel

*) $1 \text{ gcm} \approx 10^{-4} \text{ Nm}$
 $1 \text{ g} \approx 10^{-2} \text{ N}$

Limiting conditions

The following maximum values should never be exceeded.

Catalogue number 9904 120	53101	53102	53103	53104	
Maximum voltage	5	5	5	5	V _{dc}
Maximum permissible load	470	280	175	35	gcm *)
Maximum permissible input current	0.35	0.35	0.35	0.35	A
Maximum speed	130	220	350	2200	rev/min
Maximum output	0.6	0.6	0.6	0.7	W

Note- The gears of the gearbox can easily withstand a load of 1000 gcm *) on the outgoing spindle.

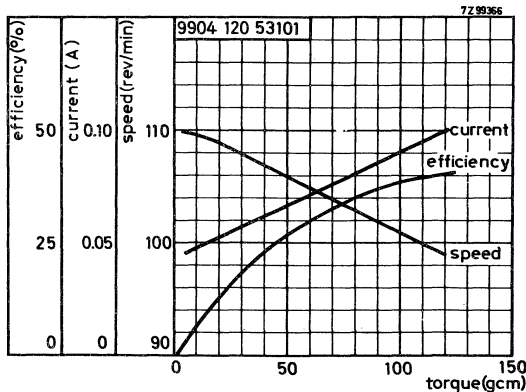
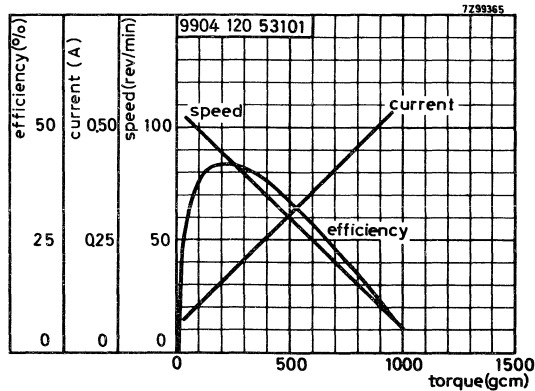

*) 1 gcm = 10⁻⁴ Nm

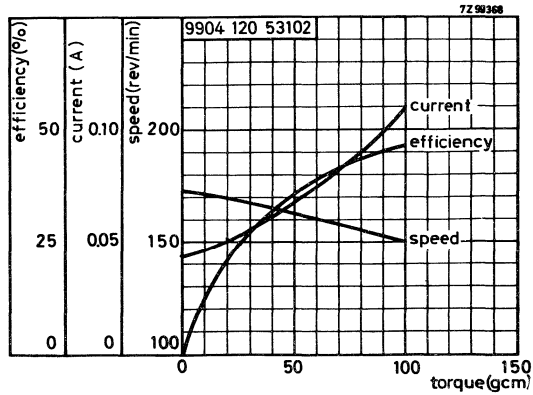
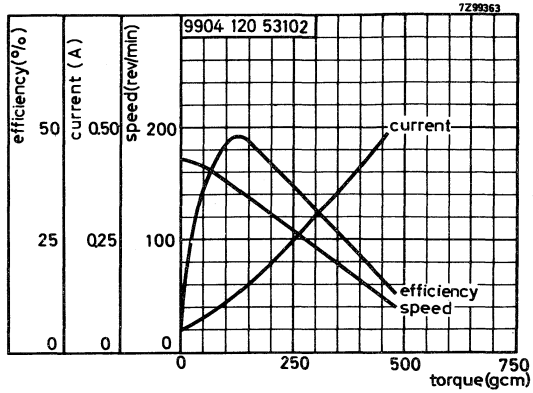

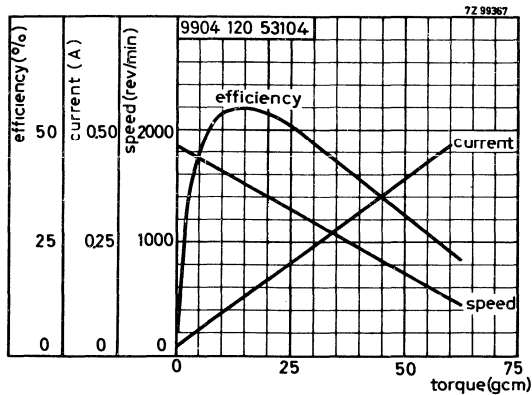
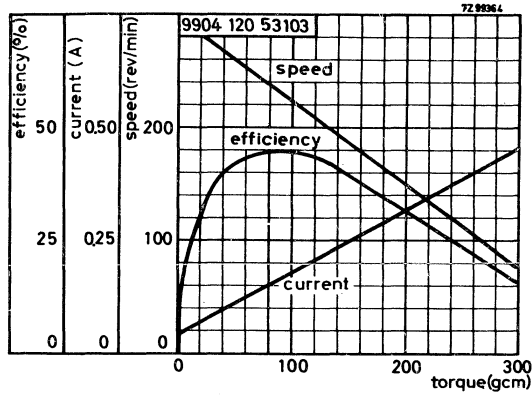

MOUNTING

The motors can be fixed by means of two screws M3 in the mounting holes of the gearbox.

The bearing of the outcoming spindle can also be used as a centring piece.

REMARKS

Versions for other supply voltages and with different speeds can be supplied on request.

In the future motors with other reduction ratios will be available.

→ A circuit diagram of an electronic 4-speed control unit can be supplied on request.

ELECTRONIC SPEED CONTROL UNIT
for direct current motors
9904 120 01501 and 9904 120 01502

RZ 27077-3

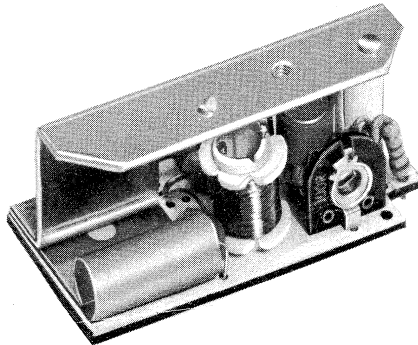

QUICK REFERENCE DATA	
Voltage range	5 to 9 V _{dc}
Speed	2000 rev/min
Torque	≥ 6 gcm*)

GENERAL

With this electronic speed control unit the speed of the motor 9904 120 01501 or 9904 120 01502 is kept within narrow limits under variations in load, supply voltage and temperature.

The combination of motor and speed control unit is very suitable for use in e.g. tape recorders, record players and record changers.

The unit can be used in tropical environments.

*) 1 gcm = 10⁻⁴ Nm

TECHNICAL DATA (See also the data sheets of the motor used with the speed control unit)

Dimensions in mm

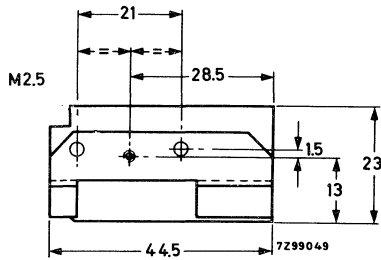
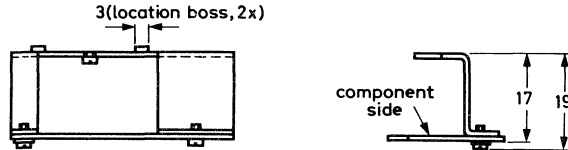

Connecting diagram

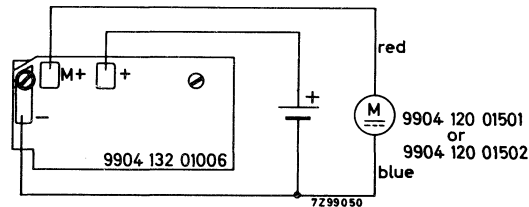

The data given below are valid for the combination of the electronic speed control unit and motor 9904 120 01501 or 9904 120 01502.

Voltage range	5 to 9 V _{dc}
Torque at 5 V _{dc}	≥ 6 gcm*)
Speed at nominal load	2000 rev/min
Current at no load	≤ 35 mA (motor) + 8 mA (control unit)
Starting torque at 5 V _{dc}	≥ 30 gcm*)
at 9 V _{dc}	≥ 60 gcm*)
Speed control range for variations of: supply voltage between 5 and 9 V _{dc} and load between 3 and 6 gcm*) and tem- perature between 0 and 45 °C	2000 rev/min + or -3%
Ambient temperature range	-10 to +50 °C

*) 1 gcm = 10⁻⁴ Nm

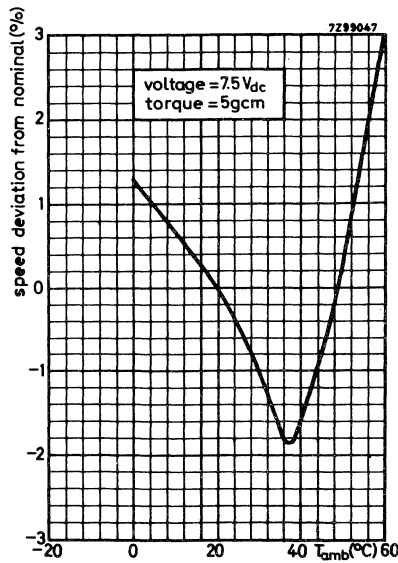
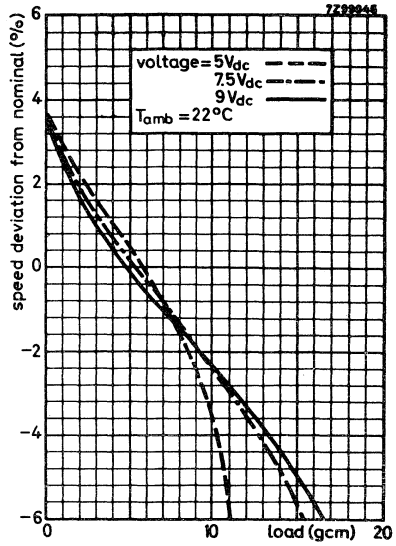
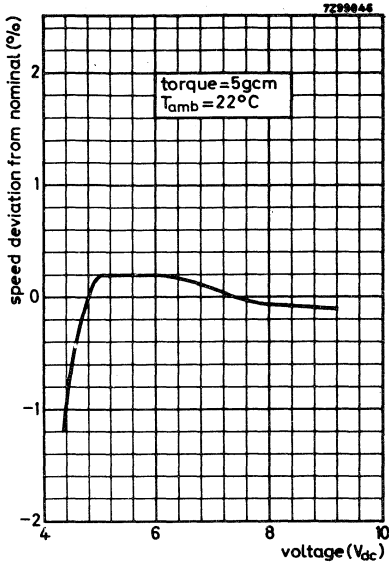

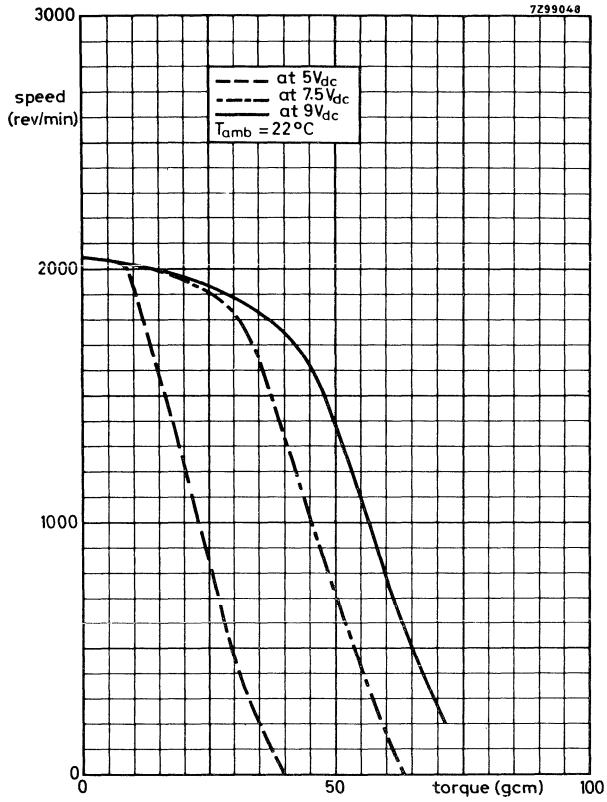

The curves are measured on an arbitrary motor.

MOUNTING

The electronic speed control unit should be mounted on a suitable heatsink.
 The unit can be fixed with a screw M 2.5.

APPLICATIONS

The uncontrolled d. c. motors can be used in a wide range of applications:

Small household appliances:

- hair dryers
- clothes and shoe brushes
- tooth brushes
- manicure sets
- fans
- scissors
- knives
- mixers
- deodorizing systems

Motor car industry:

- demister systems
- actuator systems
- radio-tuning devices
- windscreen washer pump

Toy industry:

- high quality toys
- remotely controlled toys e.g. cars, trains, boats, dolls
- building kits



DIRECT CURRENT MOTORS

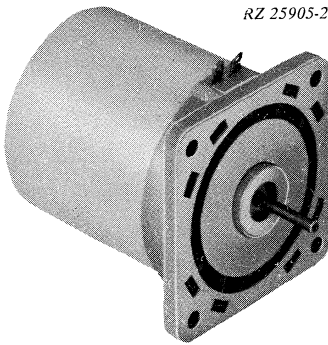

RZ 25905-2

9904 120 07401
9904 120 07601

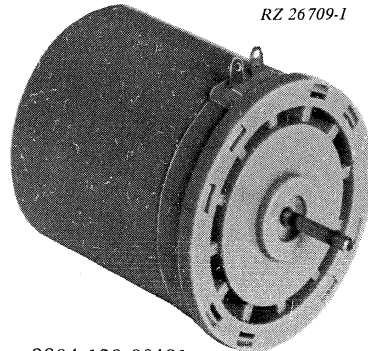

RZ 26709-1

9904 120 08401
9904 120 08601

QUICK REFERENCE DATA

Nominal voltage	6 V _{dc}
motors 9904 120 07401 and 9904 120 08401	12 V _{dc}
motors 9904 120 07601 and 9904 120 08601	
Speed	3900 rev/min
Input power	2 W
Torque	30 gcm *)

APPLICATION

These small d.c. motors have been designed for applications which require high quality and long life.

Examples:

- motor car industry: fans, demister systems, actuator systems,
- small-household-appliance industry: electrical cloth and shoe brushes, deodorised systems, hair dryers,
- toy industry: high quality toys and building kits.

*) 1 gcm $\approx 10^{-4}$ Nm

DESCRIPTION

The motor has been provided with a permanent-magnet system. It has a grey, injection - moulded housing of polyacetal resin, which offers an excellent resistance to chemicals and corrosion. A special advanced construction of a flat commutator, brass-graphite brushes, and a built-in spark suppressor (V.D.R.) guarantee a good performance during its whole life.

TECHNICAL DATA

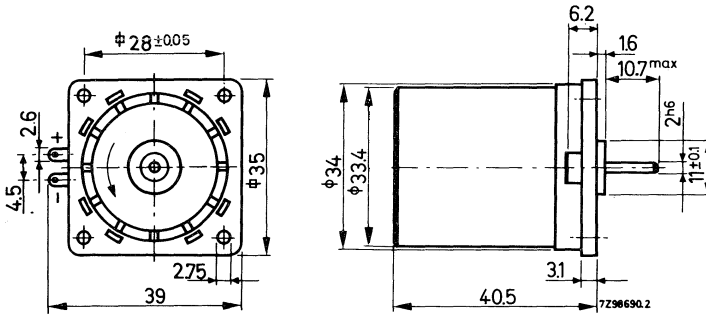

D.C. motors 9904 120 07401 and 9904 120 07601. The direction of rotation is given in connection with the polarity.

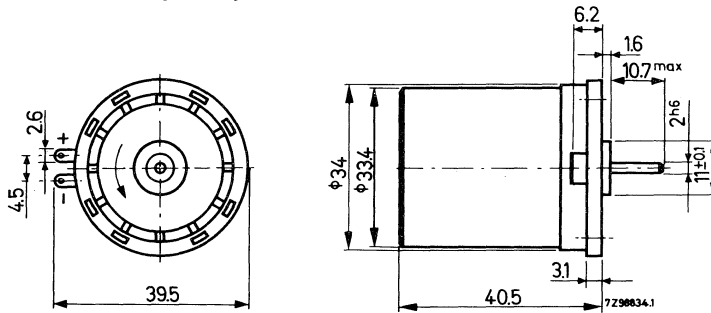

D.C. motors 9904 120 08401 and 9904 120 08601. The direction of rotation is given in connection with the polarity.

Weight

approx. 90 g

The values given below apply to an ambient temperature of $22 \pm 5^\circ\text{C}$, an atmospheric pressure of 860 - 1060 mbar and a relative humidity of 45 - 75%.

Nominal values

	motors 9904 120 07401 and 9904 120 08401	motors 9904 120 07601 and 9904 120 08601
Voltage	6 V _{dc}	12 V _{dc}
Torque	30 gcm*)	
Speed at nominal load	3900 rev/min	
at no load	4900 rev/min	
Current at nominal load	0.375 A	0.190 A
at no load	0.095 A	0.055 A
Starting torque	min. 120 gcm*)	
Input power	2 W	
Direction of rotation	reversible, see dimensional drawing	
Ambient temperature range	-20 to +60 °C	
Bearings	sintered bronze; self-lubricating	
Maximum radial force on the bearings	250 g*)	
Maximum axial force	200 g*)	
Housing, material	polyacetal resin	
colour	grey	

Limiting conditions

The following maximum values should never be exceeded.

	motors 9904 120 07401 and 9904 120 08401	motors 9904 120 07601 and 9904 120 08601
Maximum voltage	12 V _{dc}	24 V _{dc}
Maximum permissible load at 6 V _{dc}	60 gcm*)	60 gcm *)
at 12 V _{dc}	30 gcm*)	30 gcm *)
at 24 V _{dc}		

*) 1 gcm $\approx 10^{-4}$ Nm

1 g $\approx 10^{-2}$ N

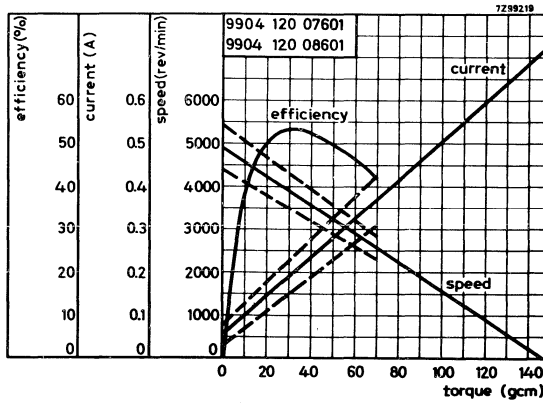
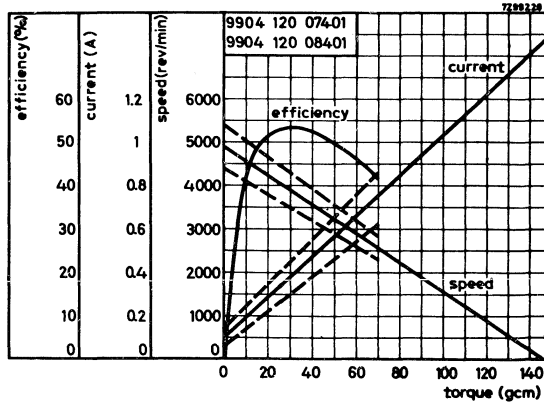

The curves in full lines are representative for our motors; these in dotted lines will give an information about the possible spread in the performances.

MOUNTING

The motors with a square flange with mounting holes (catalogue numbers 9904 120 07401 and 9904 120 07601) can be fixed by means of four screws (M 2.6) and nuts.

REMARKS

Versions for other supply voltages and with different speeds can be delivered on request.

A series of small d.c. motors with gearbox and with a square flange, offering a wide range of gear ratios, can be delivered under catalogue numbers 9904 120 51401 to 9904 120 51411 for a supply voltage of 6 V_{dc} and 9904 120 51601 to 9904 120 51611 for a supply voltage of 12 V_{dc}.

DIRECT CURRENT MOTORS with reduction

56988

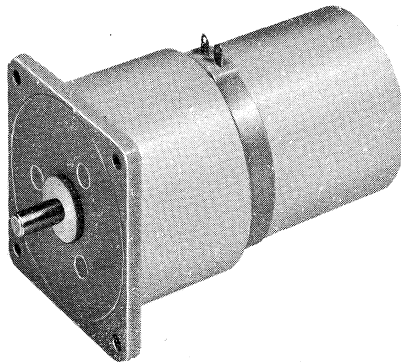

QUICK REFERENCE DATA					
catalogue numbers		reduction	speed	input	torque
nominal voltage 6 V _{dc}	nominal voltage 12 V _{dc}	ratio	(rev/min)	power (W)	(gcm *)
9904 120 51401	9904 120 51601	5.57 : 1	690	2.1	100
9904 120 51402	9904 120 51602	9 : 1	435	2.0	150
9904 120 51403	9904 120 51603	16.7 : 1	235	2.0	300
9904 120 51404	9904 120 51604	27 : 1	143	2.1	500
9904 120 51405	9904 120 51605	50 : 1	83	2.0	750
9904 120 51406	9904 120 51606	81 : 1	49	2.2	1500
9904 120 51407	9904 120 51607	150.4 : 1	28	1.5	1500
9904 120 51408	9904 120 51608	243 : 1	18	1.2	1500
9904 120 51409	9904 120 51609	451.25 : 1	9.8	1.0	1500
9904 120 51411	9904 120 51611	729 : 1	6.3	0.8	1500

*) 1gcm $\approx 10^{-4}$ Nm

APPLICATION

These small d.c. motors with integrated gearboxes have been designed for applications which require a driving motor of good quality and a long life.

Examples:

- automation systems
- chart and pen-driving units for portable recorders
- rotating antenna systems
- rotating warning lights
- positioning of searchlights e.g. on cars
- electric cloth-brushes and shoe-brushes
- high-quality toys and building kits.

DESCRIPTION

This motor has been provided with a permanent magnet system. A reduction gear box has been built in with gearwheels made of polyacetal resin; various reductions are available.

A voltage dependent resistor is built in and acts as a spark suppressor. This and the fact that the commutator is flat make for a good interference suppression so that the motor can also be remotely controlled.

The grey injection-moulded housing of polyacetal resin is highly resistant to chemicals and corrosion.

Mounting the motor is easy since it is provided with a flange having four holes.

MOUNTING

The motor can be fixed by means of four screws M2.6 and washers. (See dimensional drawing.)

TECHNICAL DATA

Dimensions in mm

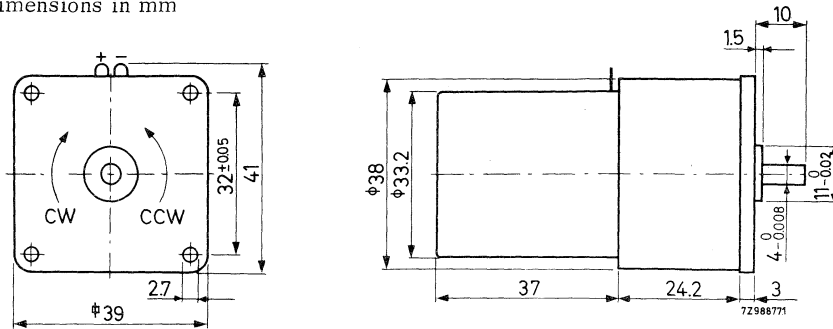

The direction of rotation is given in connection with the polarity.

The values given in the tables on pages 4 and 5 apply to an ambient temperature of $22 \pm 5^\circ\text{C}$, an atmospheric pressure of 860 - 1060 mbar and a relative humidity of 45 - 75%

Ambient temperature range	-20 to +60 °C
Bearings	bronze, self lubricating
Maximum axial play	0.5 mm
Housing, material	polyacetal resin
colour	medium grey
Gears, material	polyacetal resin
Weight	approx. 110 g



Catalogue number 9904 120 51...	401	601	402	602	403	603	404	604	405	605
Reduction ratio	5.57 : 1		9 : 1		16.7 : 1		27 : 1		50 : 1	
<u>Nominal values</u>										
Voltage	6	12	6	12	6	12	6	12	6	12
Torque	100		150		300		500		750	
Speed at nominal load	690		435		235		143		83	
at no load	845		520		280		175		94	
Current at nominal load	340	170	325	155	335	165	340	170	315	150
at no load	100	55	100	55	100	55	100	55	100	55
Input power	2.1		2.0		2.0		2.1		2.0	
Direction of rotation, see dimensional drawing	CCW		CCW		CW		CW		CCW	
Maximum radial force on the bearings	200		200		400		400		600	
Maximum axial force	200		200		400		400		600	
<u>Limiting conditions**)</u>										
Maximum voltage	12	24	12	24	12	24	12	24	12	24
Maximum permissible load	150		200		350		600		1000	
	V _{dc}		V _{dc}		V _{dc}		V _{dc}		V _{dc}	
	gcm*)		gcm*)		gcm*)		gcm*)		gcm*)	

*) 1 gcm ≈ 10⁻⁴ Nm
1 g ≈ 10⁻² N

**) These maximum values should never be exceeded.

DIRECT CURRENT MOTORS
with reduction

9904 120 514..
9904 120 516..

Catalogue number 9904 120 51...	406	606	407	607	408	608	409	609	411	611
Reduction ratio	81 : 1		150.4 : 1		243 : 1		451.25 : 1		729 : 1	
Nominal values										
Voltage	6	12	6	12	6	12	6	12	6	12
Torque	1500		1500		1500		1500		1500	
Speed at nominal load	49	28	28	31	18	19.5	9.8	10.5	6.3	6.5
at no load	58		31		19.5		10.5		6.5	
Current at nominal load	370	175	240	120	190	90	165	70	140	60
at no load	100	55	100	55	100	55	100	55	100	55
Input power	2.2		1.5		1.2		1.0		0.8	
Direction of rotation, see dimensional drawing	CCW		CW		CW		CCW		CCW	
Maximum radial force on the bearings	600		800		800		1000		1000	
Maximum axial force	600		800		800		1000		1000	
Limiting conditions **)										
Maximum voltage	12	24	12	24	12	24	12	24	12	24
Maximum permissible load	1500		1500		1500		1500		1500	
	V _{dc}		gcm [*])		rev/min		mA		W	

*) 1 gcm $\approx 10^{-4}$ Nm
1 g $\approx 10^{-2}$ N

**) These maximum values should never be exceeded.



The solid curves are typical, the dotted ones indicate the spread in the performances.

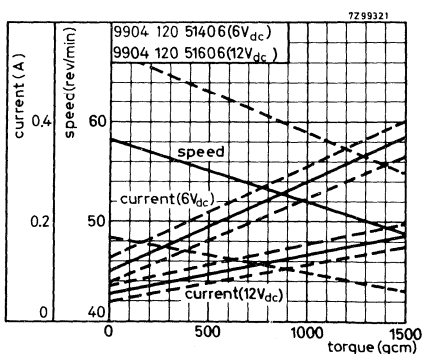
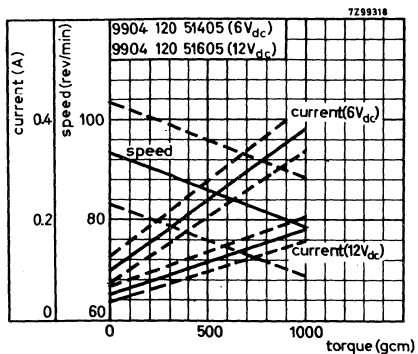
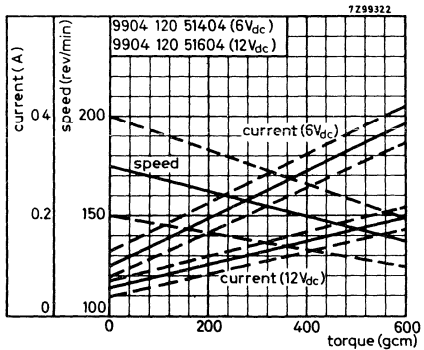
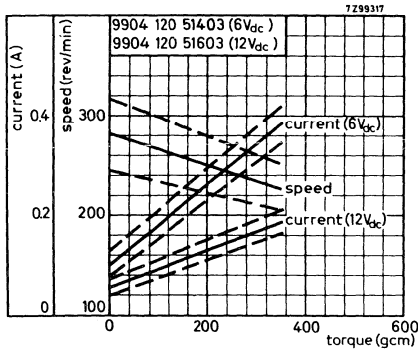
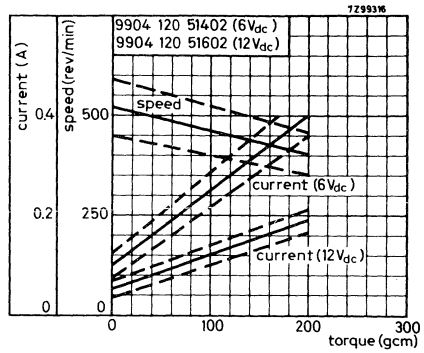
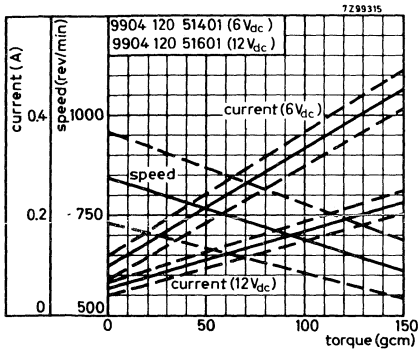

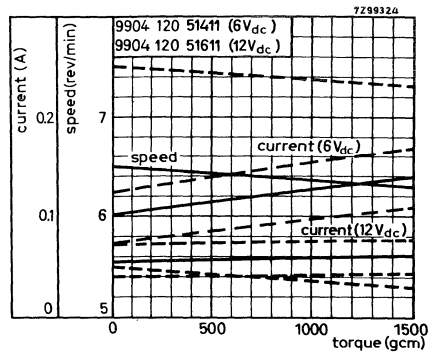
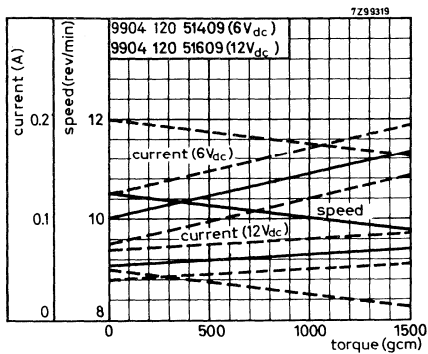
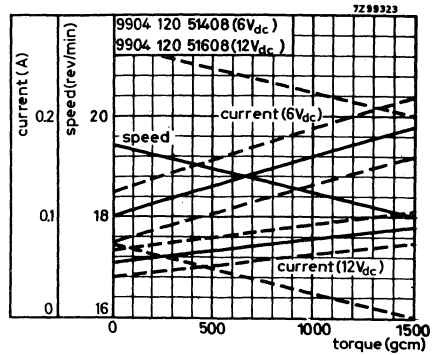
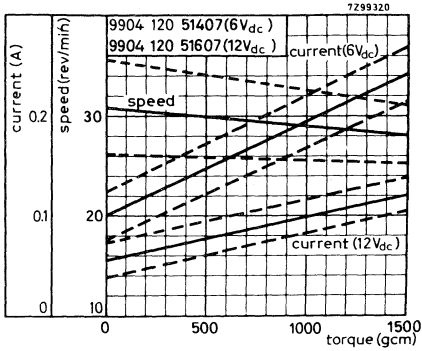

REMARKS

Versions for other supply voltages can be supplied on request.

Motors with metal gearwheels are available for higher output torques.

DIRECT CURRENT MOTOR DRIVE UNIT with integrated gearbox

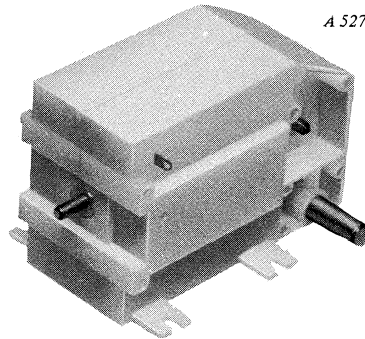

A 52731-1

QUICK REFERENCE DATA

Nominal voltage	4.5	V _{dc}
Speed	225	rev/min
Input power	1.7	W
Torque	200	gcm *)

APPLICATION

This small d.c. motor drive unit with integrated gearbox has been especially designed for the toy industry (making toy cars, trains, sewing machines, dolls, etc.). It has a high-speed and a low-speed spindle so that it is highly suited for a combined function, e.g. in model helicopters or airplanes, where the low-speed spindle drives the wheels and the high-speed spindle the propellers.

Furthermore it can be used in small household appliances, such as electrical cloth and shoe brushes. For use in e.g. electric shavers and motorised boats, the motor can be supplied without gears.

DESCRIPTION

This motor drive unit consists of a d.c. motor and an integrated reduction gear, gear ratio 20.44 : 1. The complete assembly is encapsulated in a housing of polyacetal resin. A high-torque low-speed output is provided by the two ends of the spindle of the reduction gear. This spindle is perpendicular to the motor armature spindle, which provides a high-speed output.

Electrical connection to the motor is made by two solder tags. The motor has been provided with four mounting ears.

If interference suppression is required, e.g. for remote control purposes, the motor can be supplied with a built-in spark suppressor (V.D.R.), which does the job properly thanks to the special flat-shaped long-life commutator.

*) 1 gcm $\approx 10^{-4}$ Nm

TECHNICAL DATA
Dimensions in mm

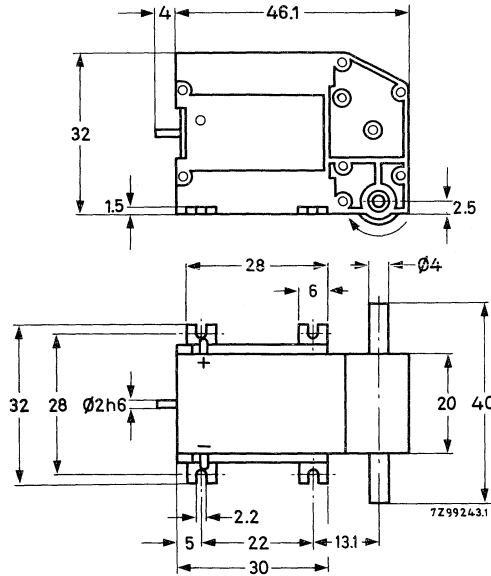

The direction of rotation is given in connection with the polarity,

Weight approx. 50 g

The values given below apply to an ambient temperature of $22 \pm 5 \text{ }^\circ\text{C}$, an atmospheric pressure of 860 - 1060 mbar and a relative humidity of 45 - 75%.

Nominal values

Voltage	4.5 V _{dc}
Torque	200 gcm [*])
Speed at nominal load	225 rev/min
at no load	280 rev/min
Current at nominal load	0.36 A
at no load	0.135 A
Starting torque	$\geq 750 \text{ gcm } ^*)$
Input power	1.7 W
Direction of rotation	reversible; see dimensional drawing
Ambient temperature range	-10 to +50 °C
Maximum radial force on the bearings	1000 g [*])
Maximum axial force	500 g [*])
Housing, material	polyacetal resin
colour	white

^{*}) 1 gcm $\approx 10^{-4}$ Nm
1 g $\approx 10^{-2}$ N

Limiting conditions

The following maximum values should never be exceeded.

Maximum voltage 6 V_{dc}

Maximum permissible load 300 gcm *)

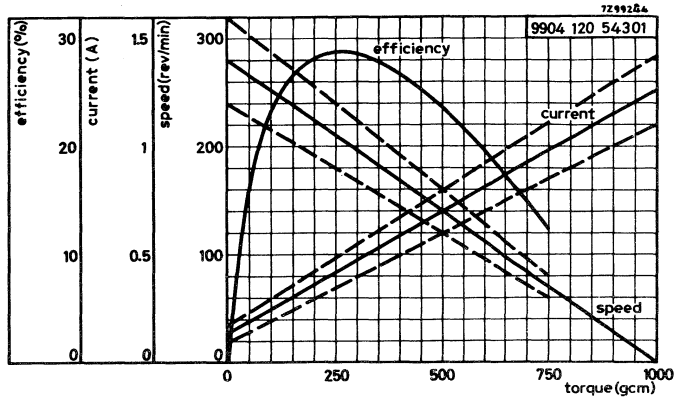

The curves in full lines are representative for our motors; these in dotted lines will give an information about the possible spread in the performances.

MOUNTING

The motor can be fixed by means of four screws.

REMARKS

Versions are available on request:

- for other supply voltages and with other speeds
- with a reduction gear spindle with other lengths (maximum 120 mm)
- with the reduction gear spindle shifted to left or to right.

*) 1 gcm $\approx 10^{-4}$ Nm

Tachogenerators and servomotors



Servomotor page D3
D.C. tachogenerators page D9

SERVOMOTOR

symmetric asynchronous type with a.c. tacho-generator

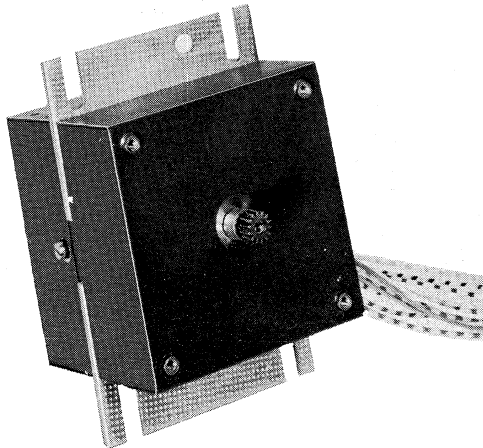

RZ 27077-10

QUICK REFERENCE DATA

Nominal voltage, reference coil	110, 220 V, 50 Hz
control coil	9, 18 V, 50 Hz
Speed at no load	≥ 2400 rev/min
Input at no load, reference coil	≤ 3 W
control coil	≤ 3 W
Maximum torque	≥ 135 gcm *)

APPLICATION

This asynchronous motor with incorporated tacho-generator has been specially designed for closed loop compensating circuits, requiring accurate setting, as used in:

- recording measuring instruments
- electronic weighing equipment
- process control equipment.

No maintenance is required. It is suitable for tropical environments.

*) $1 \text{ gcm} \approx 10^{-4} \text{ Nm}$

DESCRIPTION

The motor is equipped with 4 coils, 2 of which being mains fed (motor reference coils), whereas the other 2 (control coils) are to be connected to an amplifier.

The input of this amplifier is driven by the difference in voltage between the recording element and the potentiometer with indicator driven by the motor. If this difference is zero, the amplifier receives no input signal and supplies no output voltage to the control coils, so that the motor stops.

As soon as there is a voltage difference, the motor will begin to rotate so that the potentiometer is moved until the difference disappears again.

Owing to the momentum of motor and system, the indicator will overshoot the zero position, thus giving rise to another voltage difference which starts the motor anew. The result is that the motor will oscillate round the zero point. The built-in tachometer-generator suppresses the oscillation by generating a voltage which opposes the abovementioned voltage difference. As the indicator approaches the correct position, the voltage difference is very low and equals the e. m. f. of the generator. As a result the input voltage of the amplifier is zero before the indicator arrives at the correct point. The indicator travels to the correct point driven by the momentum of motor and system. Finally the voltage difference and the e. m. f. of the generator become zero, and the whole system is in neutral position.

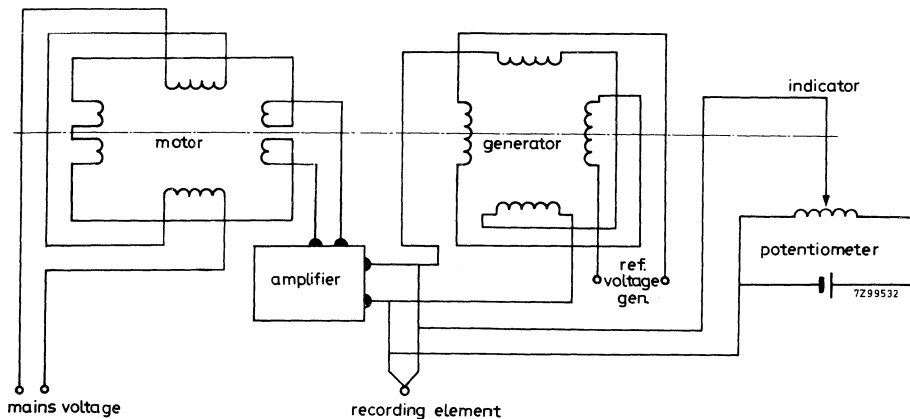

SERVOMOTOR
 symmetric asynchronous type
 with a.c. tacho-generator

9904 121 00011

TECHNICAL DATA

Dimensions in mm

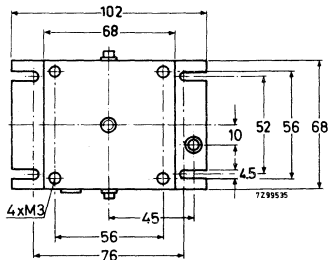
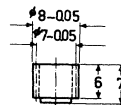
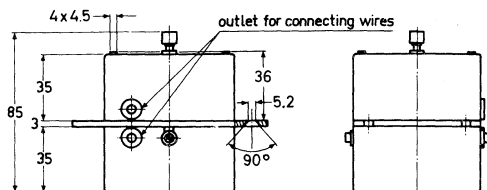

Module : 0.5

Number of teeth: 14

Height of teeth: 1.1

Connecting diagram

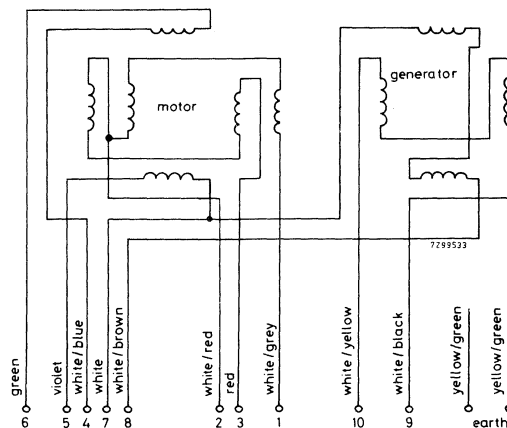

Reference coils of motor

between 4 and 7: 220 V, 50 Hz and
 5 and 6 interconnected;
 between 4 and 6: 110 V, 50 Hz,
 6 and 7 interconnected and
 4 and 5 interconnected.

Control coils of motor

between 1 and 3: 18 V, 50 Hz;
 between 1 and 2: 9 V, 50 Hz and
 between 2 and 3: 9 V, 50 Hz.

Reference coils of generator

between 7 and 8: 50 V, 50 Hz.

Outgoing coils of generator

between 9 and 10.

Weight

approx. 1000 g

The values given below are measured at 220 V_{ac} reference coil and 18 V_{ac} control coil with phase angle between the two voltages of $90 \pm 5^\circ$.

They apply to an ambient temperature of $22 \pm 5^\circ\text{C}$, an atmospheric pressure of 800-1060 mbar and a relative humidity of 45-75%.

Nominal voltage, motor reference coil	110, 220 V
motor control coil	9, 18 V
Frequency	50 Hz
Starting torque at 150 rev/min	≥ 135 gcm ^{*)}
Maximum torque	≥ 135 gcm ^{*)}
Speed at maximum torque	150 rev/min
at no load	≥ 2400 rev/min
at maximum output power	1400 rev/min
Maximum output power	≥ 1.2 W
Input power at no load, motor reference coil	≤ 3 W
motor control coil	≤ 3 W
Current at no load, motor reference coil	≤ 0.035 A
motor control coil	≤ 0.375 A
Voltage, generator reference coil	50 V, 50 Hz
Current, generator reference coil	≤ 0.02 A
Voltage, generator outgoing coil (open output voltage, 50 Hz, sinusoidal)	≥ 0.1 mV/rev/min
at 2400 rev/min	≥ 250 mV
at 0 rev/min	≤ 1.5 mV
Direction of rotation	reversible
Maximum permissible temperature of the windings	120 °C
of the bearings	80 °C
Insulation according to IEC 65	class E
Insulation test voltage	2500 V
Bearings	ball bearings
Maximum radial force on the bearings	500 g ^{*)}
Maximum axial force	100 g ^{*)}
Rotor inertia (motor and generator)	$54 \cdot 10^{-3}$ gcms ² ^{*)}
Terminals	flying leads

^{*)} 1 gcm $\approx 10^{-4}$ Nm
1 g $\approx 10^{-2}$ N

SERVOMOTOR
symmetric asynchronous type
with a.c. tacho-generator

9904 121 00011

	resistance	inductance
Motor reference coils (2 coils in series)	1350 Ω	18.2 H
Motor control coils (4 coils in series)	7.5 Ω	0.14 H
Generator reference coils (2 coils in series)	2000 Ω	7 H
Generator outgoing coils (2 coils in series)	110 Ω	0.37 H

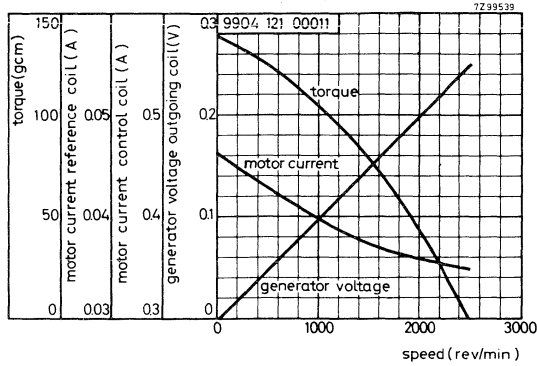

Torque, motor current reference coil, motor current control coil and generator voltage outgoing coil (open output voltage) as a function of rotor speed. The curves are measured at an arbitrary motor.

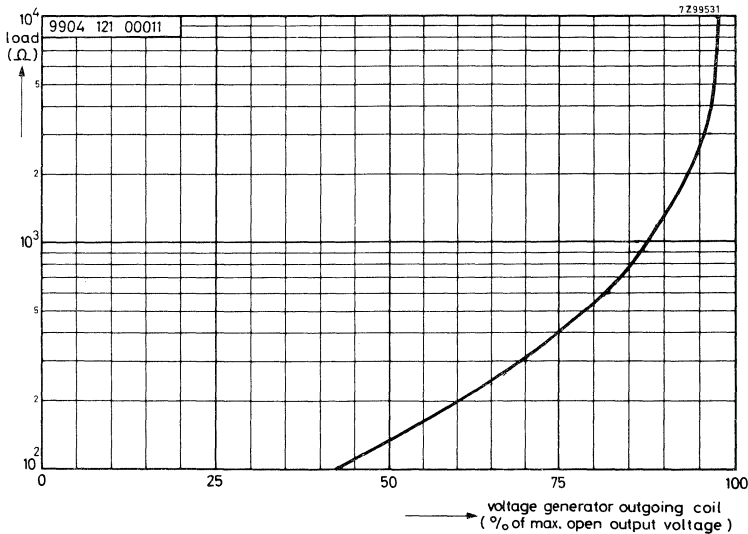

Load as a function of generator voltage outgoing coil at an arbitrary constant rotor speed. The curves are measured at an arbitrary motor.

9904 121 00011

SERVOMOTOR
symmetric asynchronous type
with a. c. tacho-generator

MOUNTING

The motor can be fixed by means of four screws M4 and/or four screws M3.

REMARKS

- Input power, current and torque are measured at an ambient temperature of 20 °C, within the first 15 s after starting the cold motor.
The speed is measured at an ambient temperature of 20 °C, 5 min after starting the cold motor.
- A voltage deviation of -10% from nominal causes the torque to decrease by about 20%.
- Versions for other supply voltages can be supplied on request.



D.C. TACHOGENERATORS

QUICK REFERENCE DATA		
Output voltage	0.06 V/rev/min	0.1 V/rev/min
Maximum permissible speed	10 000 rev/min	6000 rev/min
Maximum permissible output current	0.25 A	0.16 A
Armature resistance at 20 °C	59 Ω	165 Ω
Rotor inertia	8450 gcm ²	8450 gcm ²

A 52801-21

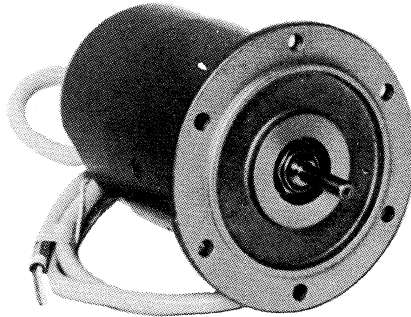

APPLICATION

This range of d. c. permanent magnet tachogenerators has been designed for use in electronic control and measuring systems.

They can be used as a link in servo control systems where d. c. feedback is required proportional to speed such as for programmed control of machine tools, acceleration and deceleration of high speed lifts, and variable speed drives of coil winding machines. For speed synchronization of rotary machines, such as in the printing, paper making and textile industries, these tachogenerators are ideally suited, for not only are the machines of a high quality type but, since they are totally enclosed they are able to operate in particle-laden atmospheres without their performance being affected in any way.

DESCRIPTION

These d. c. permanent magnet tachogenerators generate a d. c. voltage directly proportional to the speed of spindle rotation with a linearity of 0.5%.

They are available in two basic forms having outputs of 60 mV and 100 mV per revolution per minute, respectively. Peak-to-peak ripple has been reduced to less than 1% for speeds from 100 to 4500 rev/min.

Both basic forms of tachogenerators can be supplied in spigot-flange or base-mounting types. A choice of three different spindle diameters is offered.

The range of d. c. tachogenerators comprises 11 different versions; eight make up the preferred range and three others comprise the non-preferred range. Selection of one of the non-preferred versions will usually result in a longer delivery time.

The tachogenerators are of rugged design with dynamically balanced armatures running in double-shielded bearings which require no further lubrication.

TECHNICAL DATA

Dimensions in mm

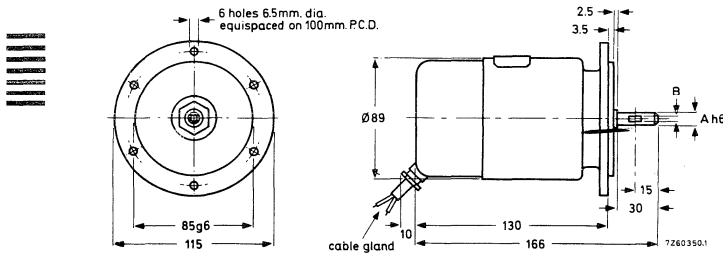

Fig. 1. Spigot-flange types of d. c. tachogenerators.

A	B
7	2.3 x 7
10	3 x 5
11	4 x 5

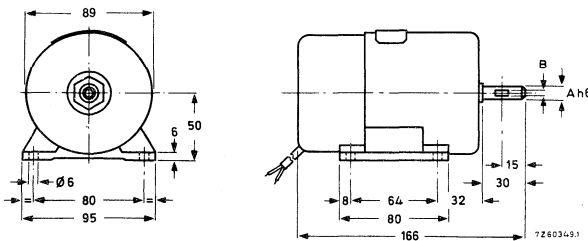

Fig. 2. Base-mounting types of d. c. tachogenerators.

Preferred range

Type	spigot-flange			base-mounting		
	7	10	11	7	10	11
Spindle diameter (mm)						
Catalogue number 9904 121 000..	32 1)	41 1)	31 2)	34 2)	53 1)	51 1)
Output voltage (V/rev/min)	0.06	0.10	0.06	0.06	0.06	0.06
Max. permissible speed (rev/min)	10 000	6000	10 000	10 000	10 000	10 000
Max. permissible output current (A)	0.25	0.16	0.25	0.25	0.25	0.25
Armature resistance at 20 °C (Ω) ± 3%	59	165	59	59	59	59

For general specification see next page.

Non-preferred range

Type	spigot-flange	
	7	11
Spindle diameter (mm)		
Catalogue number 9904 121 000..	33 2)	36 2)
Output voltage (V/rev/min)	0.06	0.06
Max. permissible speed (rev/min)	10 000	10 000
Max. permissible output current (A)	0.25	0.25
Armature resistance at 20 °C (Ω) ± 3%	59	59

Spindle extension with open ended key way

Watertight, dustproof version

Generator equipped with adaptor for over-pressure ventilation. For use in explosive surroundings
Watertight, dustproof version

For general specification see next page.

- 1) Cable, shielded, 1 metre long, wire size 2 x 0.6 mm² (flying leads)
- 2) Cable, shielded, 1 metre long, wire size 2 x 0.6 mm² (with cable gland)



Direction of rotation	reversible 1)
Max. linearity error	0.5%
Max. no load reverse error	
at 1000 rev/min	1%
Max. output voltage at no load	600 V
A. C. content (peak-to-peak) at any speed between 100 and 4500 rev/min	1% of output voltage
Voltage temperature coefficient	0.01%/degC
Max. temperature rise at maximum output current	35 degC
Ambient temperature range	
operational	-15 to +65 °C
storage	-30 to +85 °C
Insulation according IEC 65	class E
Insulation test voltage, 50 Hz, for 30 s	1700 V
Protection according IEC 34-5	ID 34
Rotor inertia	8450 gcm ²
Max. permissible radial force	10 kg
Max. permissible axial force	10 kg
Brushes	silver-graphite
Bearings	double-shielded, self-lubricated
Housing	light alloy, grey painted
Weight	
spigot-flange types	2.48 kg
base-mounting types	2.65 kg

1) For clockwise rotation (seen when looking towards the spindle) the white lead is positive.

No load conditions

A tachogenerator can be represented schematically as shown in Fig. 3, where R_i is the armature resistance and R_l represents the resistance of the external load.

The output voltage measured across the terminals marked xx is shown for no load in Fig. 4 for the 0.06 V/rev/min types and in Fig. 5 for the 0.1 V/rev/min types.

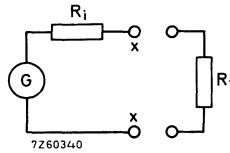

Fig. 3. Equivalent circuit of d. c. tachogenerator.

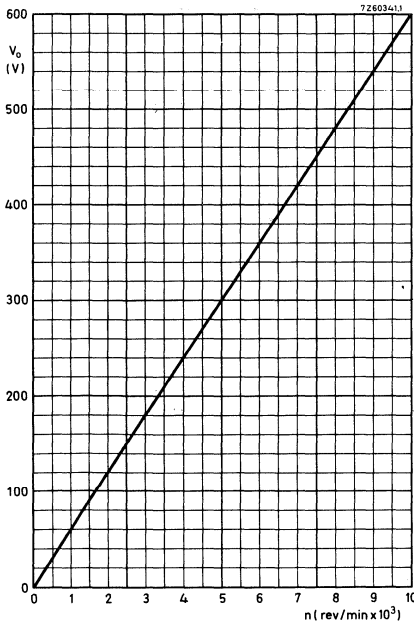

Fig. 4 No load output voltage (V_o) as a function of speed (n) for 0.06 V/rev/min types.

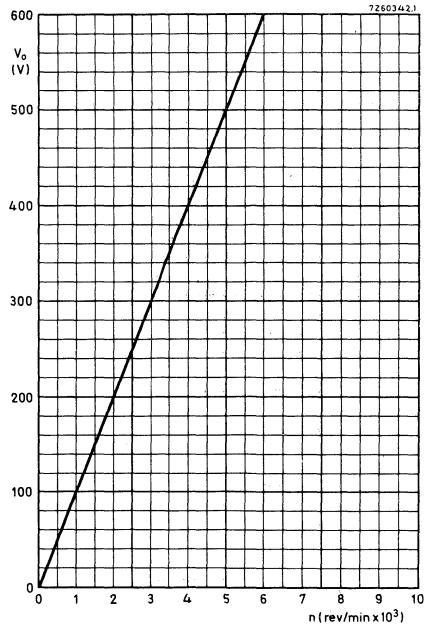

Fig. 5 No load output voltage (V_o) as a function of speed (n) for 0.1 V/rev/min types.

Output current limitations

Since the output current is limited to 250 mA and 160 mA for the 0.06 V/rev/min and the 0.1 V/rev/min types respectively, the minimum permissible load resistance in relation to the rotational speed of the tachogenerator (output voltage) must be taken into consideration.

The minimum value of external load resistance as a function of the speed is given for the 0.06 V/rev/min types in Fig. 6 and for the 0.1 V/rev/min types in Fig. 7.

Example:

The tachogenerator is required to run at 6000 rev/min.

The minimum permissible load resistance if a 0.06 V/rev/min type is used can be found directly from the graph in Fig. 6: 1381 Ω .

Alternatively, this can be calculated as follows:

$$V_o = n \times V/\text{rev}/\text{min}$$

$$R_{\text{total min}} = \frac{V_o}{I_{\text{max}}}$$

whence

$$R_{\ell \text{ min}} = R_{\text{total min}} - R_i$$

where V_o is the output voltage

n is the speed in rev/min

I_{max} is the maximum permissible current

$R_{\ell \text{ min}}$ is the minimum permissible load resistance

R_i is the armature resistance.

In the example quoted, $I_{\text{max}} = 0.25$ A and $R_i = 59$ Ω , therefore:

$$V_o = 6000 \times 0.06 = 360 \text{ V}$$

$$R_{\text{total min}} = \frac{360}{0.250} = 1440 \text{ } \Omega$$

$$R_{\ell \text{ min}} = 1440 - 59 = 1381 \text{ } \Omega$$

Note: This example does not take into account the percentage by which the no load output voltage will fall (4%) as a function of the external load resistance.

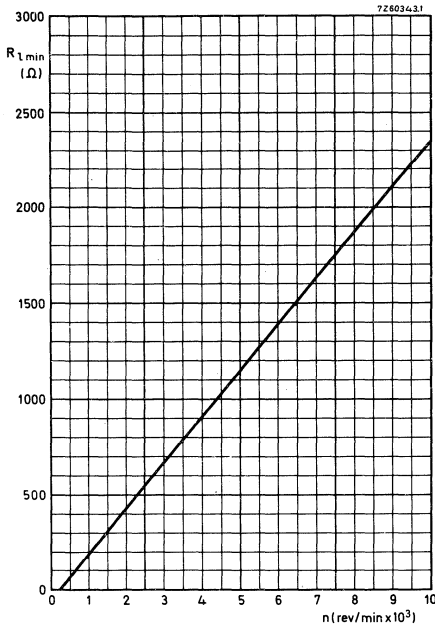

Fig. 6 Minimum permissible load resistance ($R_{l \min}$) as a function of speed (n) for 0.06 V/rev/min types.

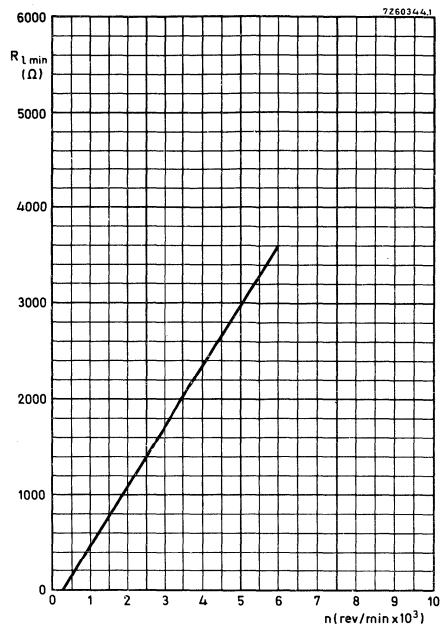

Fig. 7 Minimum permissible load resistance ($R_{l \min}$) as a function of speed (n) for 0.1 V/rev/min types.

Voltage drop as a function of external load

Although the linearity of the output voltage with respect to speed remains constant even at a voltage drop of 30%, the voltage drop must be taken into consideration.

Figs. 8 and 9 show how the voltage drop varies as a percentage of the no load voltage as a function of the external load. These graphs serve two purposes:

- to determine the variation in output voltage when a fluctuating load is applied
- to determine the correct speed for a constant load when a constant output voltage is required.

To maintain a certain voltage for a given load, the rotational speed should be increased by the percentage indicated in the graphs.

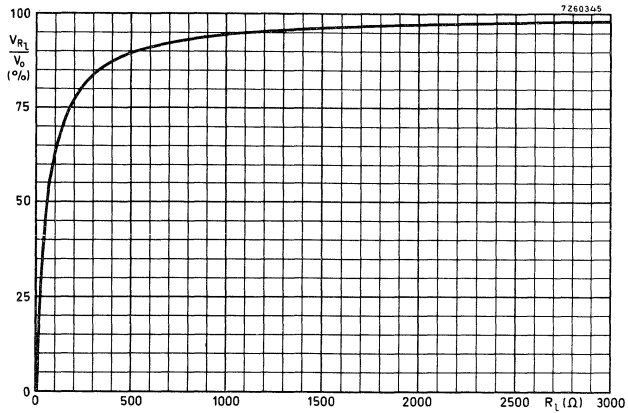

Fig. 8 Percentage drop in output voltage from its no load value as a function of external load (R_l) for 0.06 V/rev/min types.

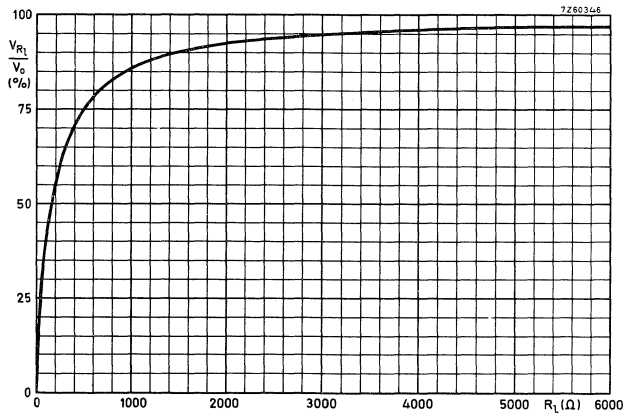

Fig. 9 Percentage drop in output voltage from its no load value as a function of external load (R_l) for 0.1 V/rev/min types.

Output power

When a tachogenerator is used to supply speed data for analogue instruments or indicators, the external load will normally be insignificant and can usually be neglected. Circumstances can arise, however, in which the tachogenerator may be called on to supply power and, taking the minimum value of external load resistance as a function of shaft rotation from Figs. 6 and 7, the output power delivered by the tachogenerator may be plotted as a function of terminal voltage. The limit of the output power which is also determined by the maximum current that may be drawn, is shown in Figs. 10 and 11 as a function of output voltage.

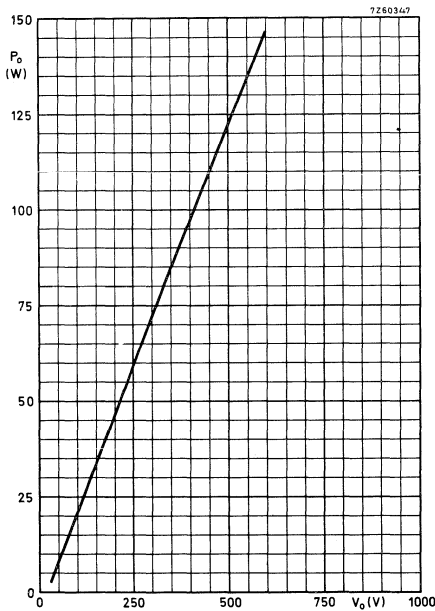

Fig. 10 Output power (P_0) as a function of output voltage (V_0) for 0.06 V/rev/min types.

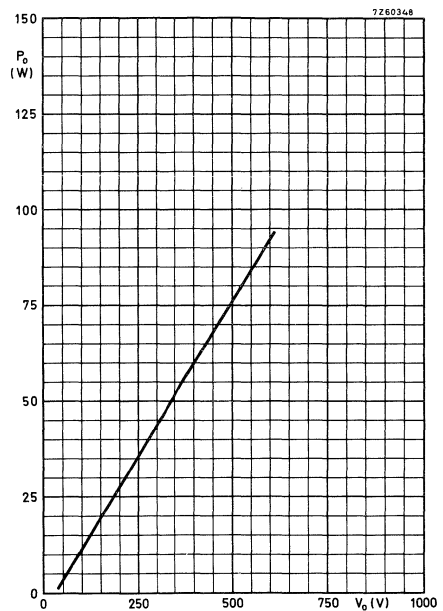

Fig. 11 Output power (P_0) as a function of output voltage (V_0) for 0.1 V/rev/min types.

MOUNTING

For position servo systems where accuracy is essential, the spigot-flange method of mounting is to be preferred. A large number of measures have been taken in the design of the machines to minimize the a. c. component due to armature eccentricity and every care should be taken to ensure accurate spindle alignment, otherwise the a. c. component may be unacceptable.

For speed control systems the base-mounting type may be preferred; the spindle is then fitted with a suitable pulley for belt drive, care being taken that both spindles are parallel to each other. Only continuous belts may be employed.

The base-mounting type is secured in position by four screws or studs.

It is important that users of tachogenerators are aware of the effects produced by incorrect mounting. Whilst every care has been taken in design to reduce the ripple content, the user can easily destroy this quality by allowing mechanical misalignment, or impacting gearing, to interfere with the smooth running of the armature. For correct mounting the following points should be borne in mind:

- the spindle of the tachogenerator should be carefully aligned with the spindle to which it is to be coupled
- eccentricity of mechanical couplings should be a minimum
- gearing should be avoided, but where gearing must be used:
 - anti-backlash gears are essential if a position control servo system is involved
 - all gears should be high quality and the tooth clearance correctly maintained by accurate centre-distances
 - a combination of nylon and resin-bonded fibre gears will give the smoothest operation
- direct coupling is preferred to gearing, but to reduce the tendency to produce ripple through misalignment of spindles, metal bellows couplings should be employed. The first point still applies, since any undue misalignment will inevitably result in destruction of the bellows through work-hardening under stress
- wherever possible, belt drive is preferred to reduce spindle vibrations transmitted through mechanical couplings.

MAINTENANCE

Lubrication is unnecessary, since the tachogenerators are fitted with double-shielded self-lubricating ball bearings with a life of 50 000 hours at 1000 rev/min without maintenance.

After every 2000 hours of running the brushes should be inspected and dust removed. The brushes are of silver-graphite and they should be carefully checked that they slide easily in their holders without them being taken out. The commutator should be cleaned with a cloth lightly soaked in trichlorethylene.

The brushes have a life of at least 10 000 hours at 1000 rev/min. When replacing the brushes it is necessary to bed them in until the contact area exceeds 70% of the brush section.

The silver-graphite brushes measure 3 x 4 x 12.5 mm and four brushes are required for each tachogenerator.

The armature should not be removed as this may affect the characteristics of the tachogenerator.

NOTE

Each tachogenerator is supplied with its own test certificate attached. Maintenance instructions are re-printed on the back of the certificate for handy reference.

Asynchronous motors



Shaded pole motors page E5

Motors with phasing capacitors page E33

INTRODUCTION

The range of asynchronous motors comprises the following types:

- shaded pole types, catalogue number 9904 122
- types with phasing capacitor, catalogue number 9904 123

They can be used in a wide range of applications.

Industrial and medical equipment:

- recording measuring instruments
- professional sound and picture recording instruments
- electronic weighing equipment
- process control equipment
- computer peripherals

Blowing equipment:

- industrial blowers
- projector cooling
- heating convectors
- ventilators

Office machines:

- type writers
- desk calculators

Household appliances:

- fans
- fan heaters
- hair dryers
- humidifiers



ASYNCHRONOUS MOTOR

symmetric shaded pole type, with fan

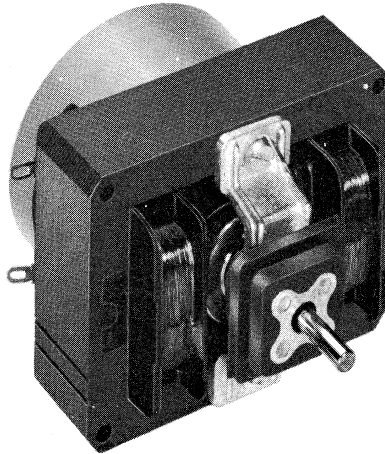

RZ 27077-1

QUICK REFERENCE DATA

Nominal voltage	110, 220	V, 50 Hz
Speed at no load	≥ 2880	rev/min
Input power at no load	≤ 33	W
Maximum torque	≥ 400	gcm ^{*)}

APPLICATION

This asynchronous motor has been designed to be used in a wide range of applications.

Examples:

- tape recorders
- desk calculators
- type writers
- medical equipment
- recording measuring instruments.

DESCRIPTION

This symmetric shaded pole motor has a large laminated section by which low induced losses have been obtained. As a result the electric rumble and the stray field around the motor are limited to a minimum. Mechanical noise has been restricted by special spindle treatment and severe tolerances on the self-adjusting slide bearings. Motor vibrations are absorbed by a rubber suspension block. The motor has been provided with a cooling fan.

It is suitable for tropical environments.

^{*)}1 gcm $\approx 10^{-4}$ Nm

TECHNICAL DATA

Dimensions in mm

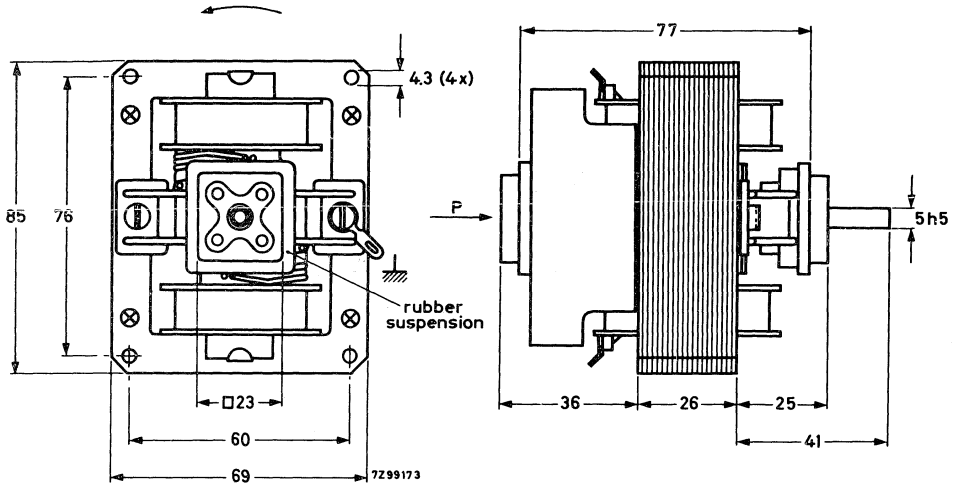

Connecting diagrams (view according to arrow P)

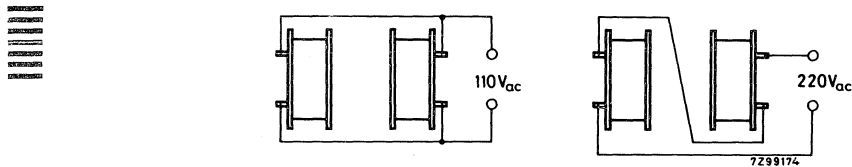

Weight

approx. 1100 g

The values given below are measured at a nominal voltage of 220 Vac; they apply to an ambient temperature of 22 ± 5 °C, an atmospheric pressure of 860-1060 mbar and a relative humidity of 45-75 %. See also "Remarks".

Nominal voltage	110, 220 Vac
Frequency	50 Hz
Starting torque at 150 rev/min	≥ 280 gcm *)
Maximum torque	≥ 400 gcm *)
Speed at maximum torque	1800 rev/min
at no load	≥ 2880 rev/min
at maximum output power	2000 rev/min
Maximum output power	≥ 8 W
Input power at no load	≤ 33 W
Current at no load	≤ 0.23 A

*) 1 gcm $\approx 10^{-4}$ Nm

Direction of rotation	counterclockwise, see dimensional drawing
Maximum permissible temperature	
of the windings	120 °C
of the bearings	80 °C
Minimum ambient temperature	-10 °C
Insulation according to I. E. C. 65	class E
Insulation test voltage	2500 V _{ac}
Bearings	self aligning slide bearings
Maximum radial force on the bearings	600 g *)
Maximum axial force	250 g *)
Maximum axial play	2 mm
Terminals	soldering tags

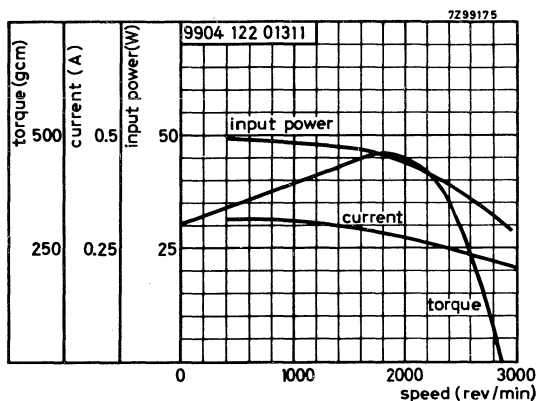

The curves are measured at an arbitrary motor.

MOUNTING

The motor can be fixed by means of four screws M4.

REMARKS

- Input power, current and torque are measured at an ambient temperature of 20 °C, within the first 15 seconds after starting the cold motor. The speed is measured at an ambient temperature of 20 °C, 5 minutes after starting the cold motor.
- A voltage deviation of -10% from nominal causes the torque to decrease by about 20%.
- Versions for other supply voltages and for an other direction of rotation can be delivered on request.

*) 1 gcm $\approx 10^{-4}$ Nm

1 g $\approx 10^{-2}$ N

ASYNCHRONOUS MOTOR symmetric, shaded pole type

RZ 27077-15

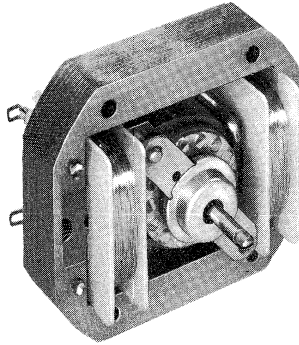

QUICK REFERENCE DATA

Nominal voltage	110, 220 V, 50 Hz
Speed at no load	≥ 2900 rev/min
Input power at no load	≤ 40 W
Maximum torque	≥ 270 gcm*)

APPLICATION

This small asynchronous motor has been designed for domestic applications.

Examples:

- hair dryers
- fans
- humidifiers

A good cooling of the motor (e.g. for use in hair dryers) is necessary.

The motor is suitable for tropical environments.

*) $1 \text{ gcm} \approx 10^{-4} \text{ Nm}$

TECHNICAL DATA

Dimensions in mm

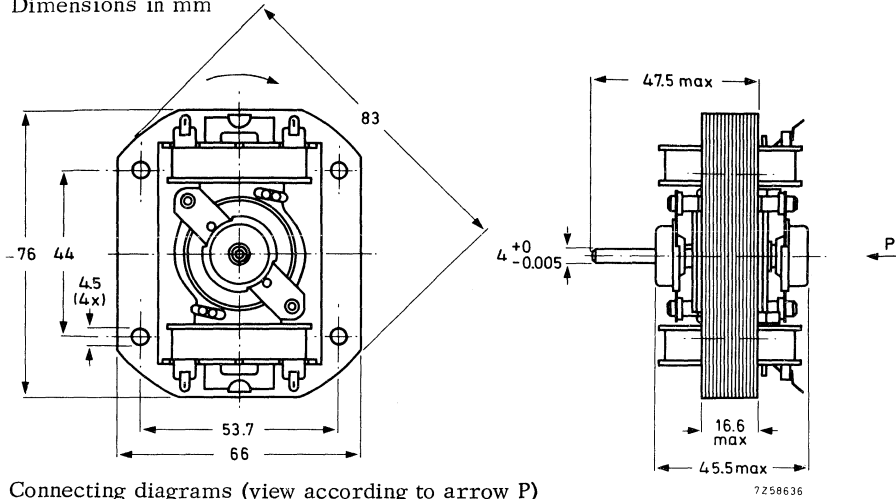

Connecting diagrams (view according to arrow P)

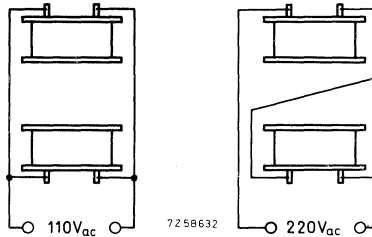

Weight

approx. 600 g

The values given below are measured at a nominal voltage of 220 V_{ac}; they apply to an ambient temperature of 22 ± 5 °C, an atmospheric pressure of 860-1060 mbar and a relative humidity of 45-75%. See also "Remarks".

Nominal voltage	110, 220 V _{ac}
Frequency	50 Hz
Starting torque at 150 rev/min	≥ 100 gcm*)
Maximum torque	≥ 270 gcm*)
Speed at maximum torque	2200 rev/min
at no load	≥ 2900 rev/min
at maximum output power	2300 rev/min
Maximum output power	≥ 6 W
Input power at no load	≤ 40 W
Current at no load	≤ 0.3 A

*) 1 gcm ≈ 10⁻⁴ Nm

Direction of rotation	clockwise, see dimensional drawing
Maximum permissible temperature	
of the windings	120 °C
of the bearings	90 °C
Minimum ambient temperature	-10 °C
Insulation according to IEC 65 and CEE 10	class E
Insulation test voltage	2500 V _{ac}
Bearings	self aligning slide bearings
Maximum radial force on the bearings	250 g [*])
Maximum axial force	350 g [*])
Maximum axial play	0.6 mm
Terminals	soldering tags

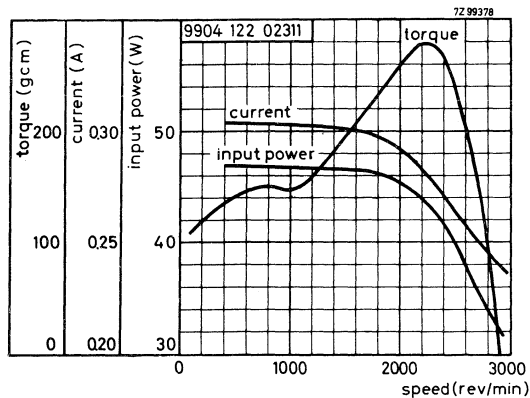

The curves are measured on an arbitrary motor.

MOUNTING

The motor can be fixed by means of four screws M4.

REMARKS

- Input power, current and torque are measured at an ambient temperature of 20 °C, within the first 15 seconds after starting the cold motor. The speed is measured at an ambient temperature of 20 °C, 5 minutes after starting the cold motor.
- A voltage deviation of -10% from nominal causes the torque to decrease by about 20%.
- Versions for other supply voltages and for an other direction of rotation can be supplied on request.

*) 1 g \approx 10⁻² N

ASYNCHRONOUS MOTOR asymmetric, shaded pole type

RZ 27077-17

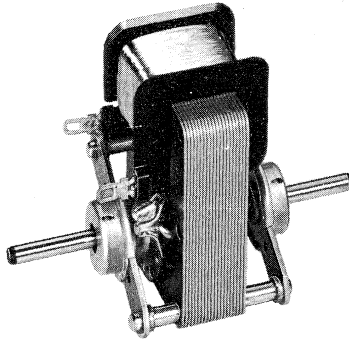

QUICK REFERENCE DATA	
Nominal voltage	220 V, 50 Hz
Speed at no load	≥ 2700 rev/min
Input power at no load	≤ 17 W
Maximum torque	≥ 75 gcm*)

APPLICATION

This asynchronous motor is mainly intended for fans, forced cooling being required.

DESCRIPTION

This small asymmetric shaded pole motor has been provided with two spindle ends. It has self-aligning slide bearings. The motor is suitable for tropical environments.

*) 1 gcm $\approx 10^{-4}$ Nm

TECHNICAL DATA

Dimensions in mm

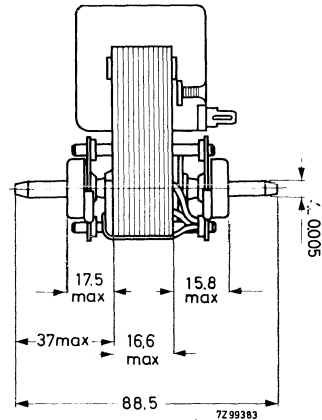
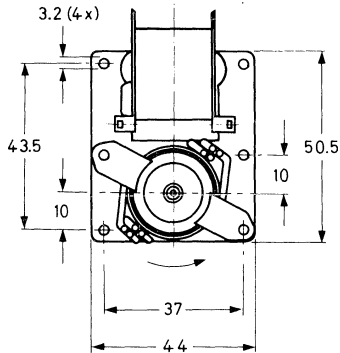

Weight

approx. 325 g

The values given below apply to an ambient temperature of 22 ± 5 °C, an atmospheric pressure of 860-1060 mbar and a relative humidity of 45-75%. See also "Remarks".

Nominal voltage	220 V _{ac}
Frequency	50 Hz
Starting torque at 150 rev/min	≥ 60 gcm*)
Maximum torque	≥ 75 gcm*)
Speed at maximum torque	1700 rev/min
at no load	≥ 2700 rev/min
at maximum output power	1800 rev/min
Maximum output power	≥ 1.35 W
Input power at no load	≤ 17 W
Current at no load	≤ 0.13 A
Direction of rotation	counterclockwise, see dimensional drawing
Maximum permissible temperature	
of the windings	120 °C
of the bearings	80 °C
Minimum ambient temperature	-10 °C
Insulation according to IEC 65 and CEE 10	class E
Insulation test voltage	2500 V _{ac}
Bearings	self aligning slide bearings

*) 1 gcm $\approx 10^{-4}$ Nm

Maximum radial force on the bearings 250 g*)
 Maximum axial force 35 g*)
 Maximum axial play 0.6 mm
 Terminals soldering tags

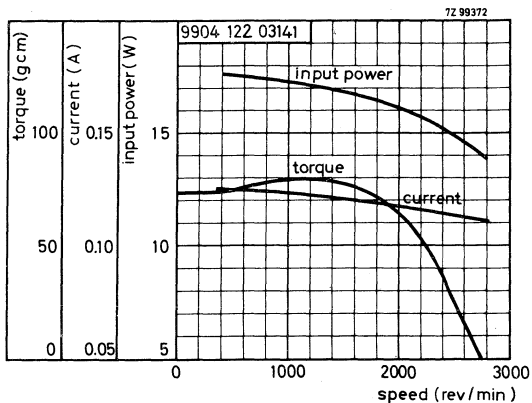

The curves are measured on an arbitrary motor.

MOUNTING

The motor can be fixed by means of four screws M3.

REMARKS

- Input power, current and torque are measured at an ambient temperature of 20 °C, within the first 15 seconds after starting the cold motor.
 The speed is measured at an ambient temperature of 20 °C, 5 minutes after starting the cold motor.
- A voltage deviation of -10% from nominal causes the torque to decrease by about 20%.
- Versions for other supply voltages and for an other direction of rotation can be supplied on request.

*) 1 g $\approx 10^{-2}$ N

ASYNCHRONOUS MOTOR asymmetric, shaded pole type

RZ 27077-20

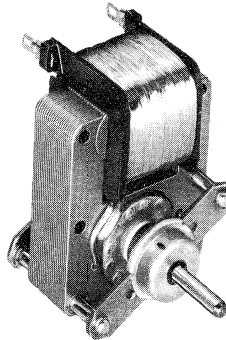

QUICK REFERENCE DATA

Nominal voltage	220 V, 50 Hz
Speed at no load	≥ 2850 rev/min
Input power at no load	≤ 13 W
Maximum torque	≥ 80 gcm *)

APPLICATION

This small asynchronous motor has been designed for use in household appliances, e.g. fans. Furthermore it can be used in office machines, vending machines, etc. The motor is suitable for tropical environments.

*) $1 \text{ gcm} \approx 10^{-4} \text{ Nm}$

TECHNICAL DATA

Dimensions in mm

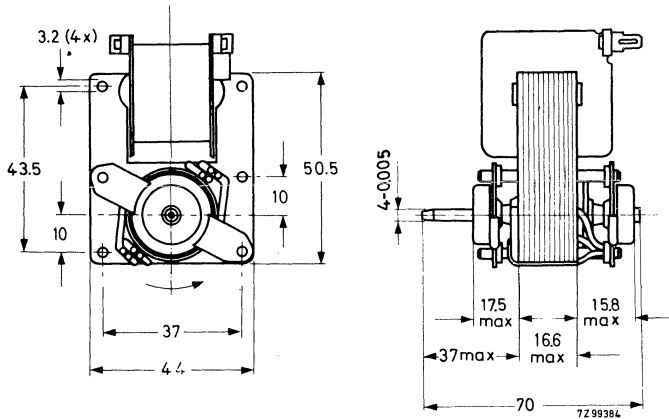

Weight

approx. 330 g

The values given below apply to an ambient temperature of 22 ± 5 °C, an atmospheric pressure of 860 - 1060 mbar and a relative humidity of 45-75%. See also "Remarks".

Nominal voltage	220 V _{ac}
Frequency	50 Hz
Starting torque at 150 rev/min	≥ 53 gcm *)
Maximum torque	≥ 80 gcm *)
Speed at maximum torque	1800 rev/min
at no load	≥ 2850 rev/min
at maximum output power	2000 rev/min
Maximum output power	≥ 1.5 W
Input power at no load	≤ 13 W
Current at no load	≤ 0.11 A
Direction of rotation	counterclockwise, see dimensional drawing
Maximum permissible temperature	
of the windings	120 °C
of the bearings	90 °C
Minimum ambient temperature	-10 °C
Insulation according to IEC 65 and CEE 10	class E
Insulation test voltage	2500 V _{ac}
Bearings	self aligning slide bearings

*) 1 gcm ≈ 10⁻⁴ Nm

Maximum radial force on the bearings	250 g*)
Maximum axial force	35 g*)
Maximum axial play	0.6 mm
Terminals	soldering tags

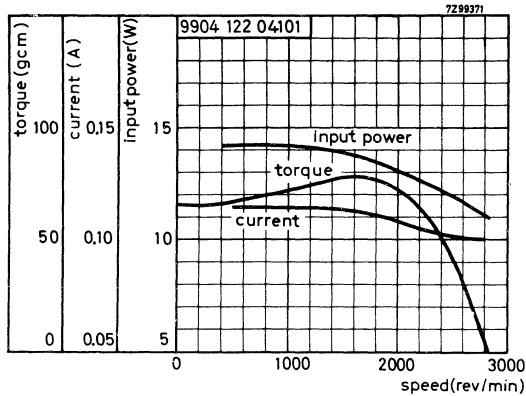

The curves are measured on an arbitrary motor.

MOUNTING

The motor can be fixed by means of four screws M3.

REMARKS

- Input power, current and torque are measured at an ambient temperature of 20 °C, within the first 15 seconds after starting the cold motor. The speed is measured at an ambient temperature of 20 °C, 5 minutes after starting the cold motor.
- A voltage deviation of -10% from nominal causes the torque to decrease by about 20%.
- Versions for other supply voltages and for an other direction of rotation can be supplied on request.

*) 1 g \approx 10⁻² N

ASYNCHRONOUS MOTOR asymmetric shaded pole type

RZ 27077-14

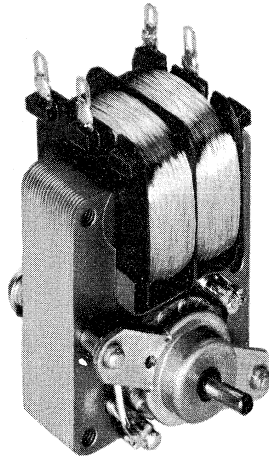

QUICK REFERENCE DATA

Nominal voltage	110, 220 V, 50 Hz
Speed at no load	\geq 2825 rev/min
Input power at no load	\leq 6 W
Maximum torque	\geq 30 gcm *)

APPLICATION

This asynchronous motor has been designed for applications which require a low noise level, e.g. record players, fans, medical equipment.

DESCRIPTION

In this small asymmetric shaded pole motor the electric rumble level is kept very low thanks to the low induced losses and the small torque. Mechanical noise has been restricted by special spindle treatment and severe tolerances on the self-adjusting slide bearings. The motor is suitable for tropical environments.

*) 1 gcm \approx 10^{-4} Nm

TECHNICAL DATA

Dimensions in mm

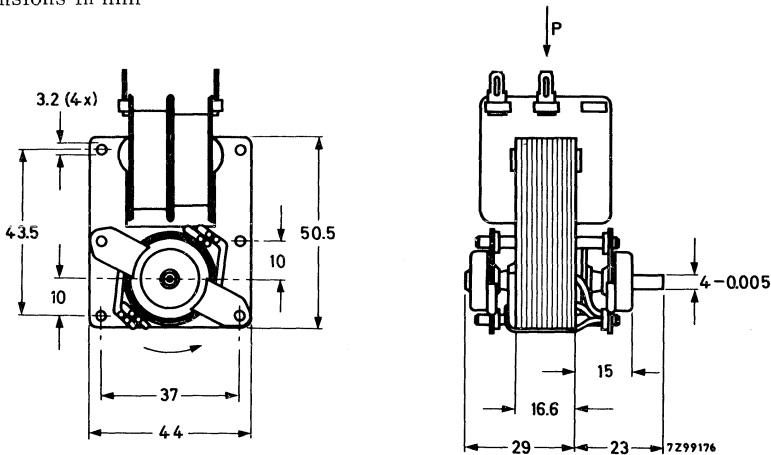

Connecting diagrams (view according to arrow P)

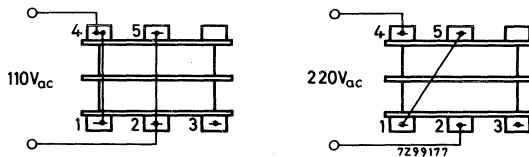

Weight

approx. 350 g

The values given below are measured at a nominal voltage of 220 V_{ac}; they apply to an ambient temperature of 22 ± 5 °C, an atmospheric pressure of 860-1060 mbar and a relative humidity of 45-75 %. See also "Remarks".

Nominal voltage	110, 220 V _{ac}
Frequency	50 Hz
Starting torque at 150 rev/min	≥ 20 gcm *)
Maximum torque	≥ 30 gcm *)
Speed at maximum torque	2000 rev/min
at no load	≥ 2825 rev/min
at maximum output power	2200 rev/min
Maximum output power	≥ 0.6 W
Input power at no load	≤ 6 W
Current at no load	≤ 0.045 A
Direction of rotation	counterclockwise, see dimensional drawing

*) 1 gcm ≈ 10⁻⁴ Nm

Maximum permissible temperature	
of the windings	120 °C
of the bearings	80 °C
Minimum ambient temperature	-10 °C
Insulation according to I. E. C. 65	class E
Insulation test voltage	2500 V _{ac}
Bearings	self aligning slide bearings
Maximum radial force on the bearings	250 g *)
Maximum axial force	35 g *)
Maximum axial play	2.7 mm
Terminals	soldering tags

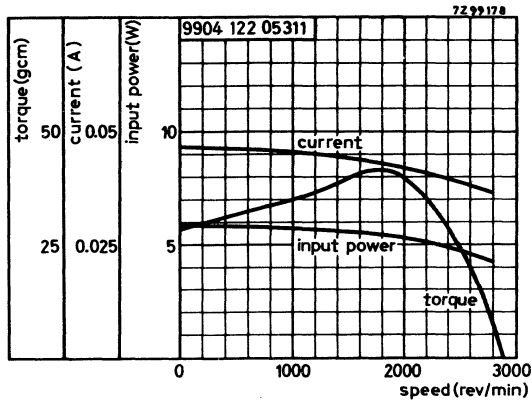

The curves are measured at an arbitrary motor.

MOUNTING

The motor can be fixed by means of four screws M3.

REMARKS

- Input power, current and torque are measured at an ambient temperature of 20 °C, within the first 15 seconds after starting the cold motor.
The speed is measured at an ambient temperature of 20 °C, 5 minutes after starting the cold motor.
- A voltage deviation of -10% from nominal causes the torque to decrease by about 20%.
- Versions for other supply voltages and for an other direction of rotation can be delivered on request.

*) 1 gcm $\approx 10^{-4}$ Nm
1 g $\approx 10^{-2}$ N

ASYNCHRONOUS MOTOR

symmetric, shaded pole type

RZ 27077-19

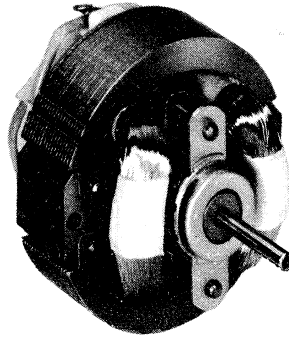

QUICK REFERENCE DATA

Nominal voltage	110, 220 V, 50 Hz
Speed at no load	\geq 2700 rev/min
Input power at no load	\leq 13 W
Maximum torque	\geq 50 gcm*)

APPLICATION

This small asynchronous motor has been designed for use in household appliances, e.g. fans. Furthermore it can be used in office machines, vending machines, etc. The motor is suitable for tropical environments.

*) 1 gcm \approx 10^{-4} Nm

TECHNICAL DATA

Dimensions in mm

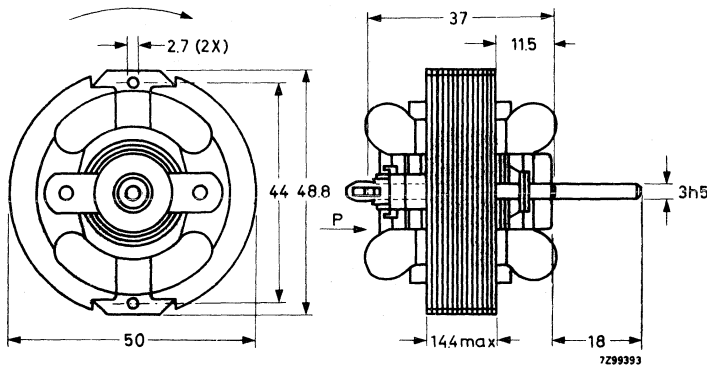

Connecting diagrams (view according to arrow P)

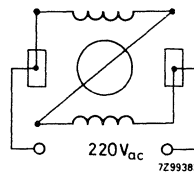
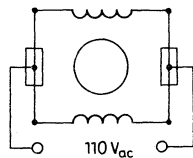

Weight

approx. 250 g

The values given below are measured at a nominal voltage of 220 V_{ac}; they apply to an ambient temperature of 22 ± 5 °C, an atmospheric pressure of 860 - 1060 mbar and a relative humidity of 45-75%. See also "Remarks".

Nominal voltage	110, 220 V _{ac}
Frequency	50 Hz
Starting torque at 150 rev/min	≥ 26 gcm [*])
Maximum torque	≥ 50 gcm [*])
Speed at maximum torque	1900 rev/min
at no load	≥ 2700 rev/min
at maximum output power	2000 rev/min
Maximum output power	≥ 1 W
Input power at no load	≤ 13 W
Current at no load	≤ 0.085 A

^{*}) 1 gcm ≈ 10⁻⁴ Nm

Direction of rotation	clockwise, see dimensional drawing
Maximum permissible temperature	
of the windings	120 °C
of the bearings	90 °C
Minimum ambient temperature	-10 °C
Insulation according to CEE 10	classe E
Insulation test voltage	2500 V _{ac}
Bearings	self aligning slide bearings
Maximum radial force on the bearings	300 g [*])
Maximum axial force	250 g [*])
Maximum axial play	0.7 mm
Terminals	soldering tags

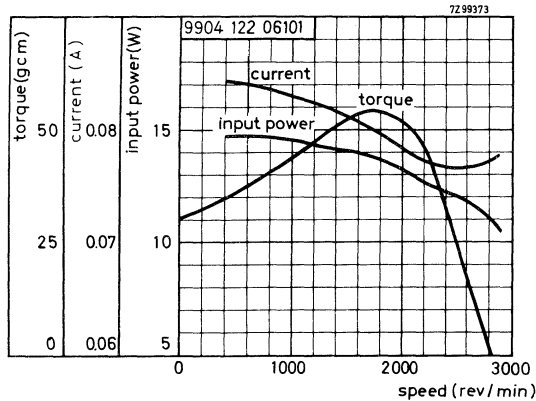

The curves are measured on an arbitrary motor.

MOUNTING

The motor can be fixed by means of two screws M2.6.

REMARKS

- Input power, current and torque are measured at an ambient temperature of 20 °C, within the first 15 seconds after starting the cold motor. The speed is measured at an ambient temperature of 20 °C, 5 minutes after starting the cold motor.
- A voltage deviation of -10% from nominal causes the torque to decrease by about 20%.
- Versions for other supply voltages and for an other direction of rotation can be supplied on request.

*) 1 g \approx 10⁻² N

ASYNCHRONOUS MOTOR

symmetric, shaded pole type, with fan

RZ 27077-18

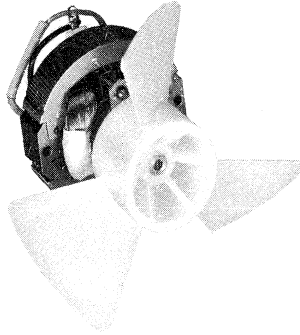

QUICK REFERENCE DATA

Nominal voltage	110, 220 V, 50 Hz
Speed at no load	≥ 2700 rev/min
Input power at no load	≤ 13 W
Maximum torque	≤ 50 gcm ^{*)}

APPLICATION

This small asynchronous motor with fan is mainly intended for use as cooling unit in industrial appliances where a low noise level is required.

The motor is suitable for tropical environments.

^{*)} 1 gcm ≈ 10⁻⁴Nm

TECHNICAL DATA

Dimensions in mm

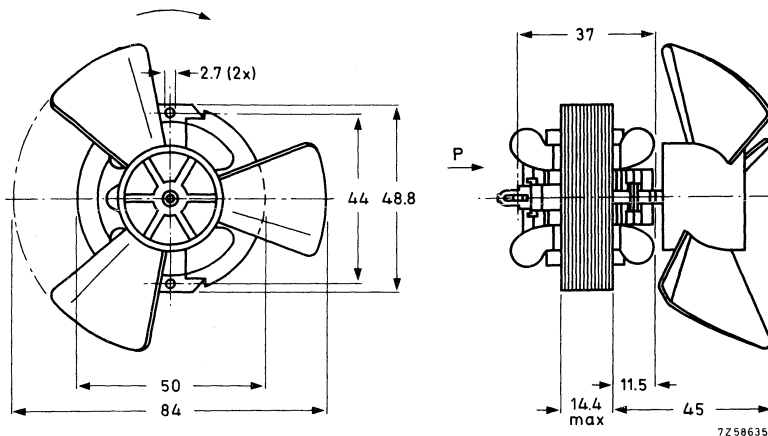

Connecting diagrams (view according to arrow P)

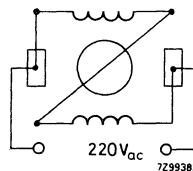
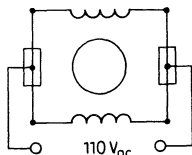

Weight

approx. 250 g

The values given below are measured at a nominal voltage of 220 V_{ac}; they apply to an ambient temperature of 22 ± 5 °C, an atmospheric pressure of 860 - 1060 mbar and a relative humidity of 45-75%. See also "Remarks".

Nominal voltage	110, 220 V _{ac}
Frequency	50 Hz
Starting torque at 150 rev/min	≥ 26 gcm *)
Maximum torque	≥ 50 gcm *)
Speed at maximum torque	1900 rev/min
at no load	≥ 2700 rev/min
at maximum output power	2000 rev/min
Maximum output power	≥ 1 W
Input power at no load	≤ 13 W
Current at no load	≤ 0.085 A

*) 1 gcm ≈ 10⁻⁴ Nm

Direction of rotation	clockwise, see dimensional drawing
Maximum permissible temperature	
of the windings	120 °C
of the bearings	90 °C
Minimum ambient temperature	-10 °C
Insulation according to CEE 10	class E
Insulation test voltage	2500 V _{ac}
Bearings	self aligning slide bearings
Maximum radial force on the bearings	300 g *)
Maximum axial force	250 g *)
Maximum axial play	0.7 mm
Terminals	soldering tags
Air displacement at an	
air pressure of 1 mm WG **)	30 m ³ /h

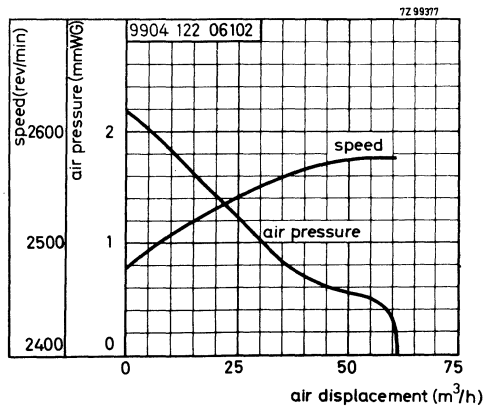
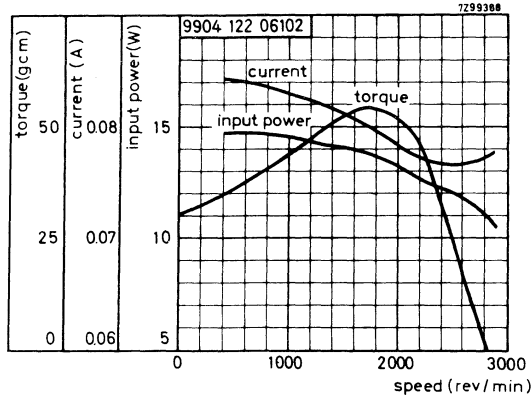

The curves are measured on an arbitrary motor.

*) 1 g $\approx 10^{-2}$ N

**) 1 mm WG ≈ 1 kg/m²

MOUNTING

The motor can be fixed by means of two screws M2.6.

REMARKS

- Input power, current and torque are measured at an ambient temperature of 20 °C, within the first 15 seconds after starting the cold motor. The speed is measured at an ambient temperature of 20 °C, 5 minutes after starting the cold motor.
- A voltage deviation of -10% from nominal causes the torque to decrease by about 20%.
- Versions for other supply voltages and for an other direction of rotation can be supplied on request.



ASYNCHRONOUS MOTOR with phasing capacitor

RZ 27077-16

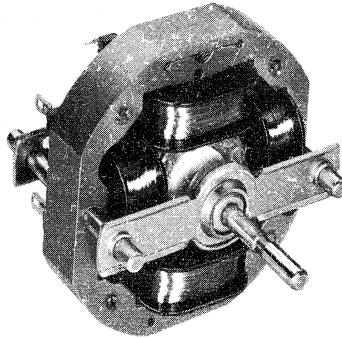

QUICK REFERENCE DATA

Nominal voltage	110, 220 V, 50 Hz
Speed at no load	~ 2500 rev/min
Input power at no load	~ 14 W
Maximum torque	~ 155 gcm*)

APPLICATION

This small asynchronous motor with high starting torque is intended for applications where a high speed is not allowed because of noise restrictions.

Examples:

- musical equipment
- vending machines
- office machines
- fans.

The motor is suitable for tropical environments.

*) 1 gcm $\approx 10^{-4}$ Nm

TECHNICAL DATA

Dimensions in mm

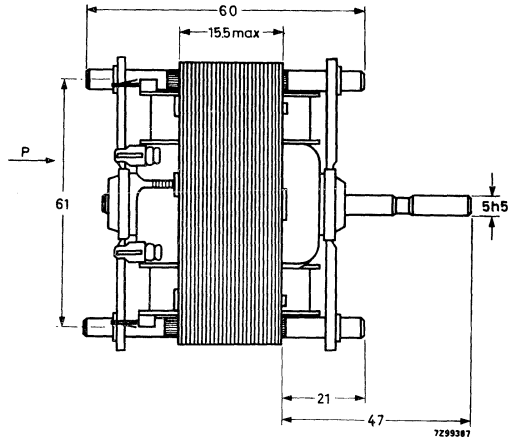
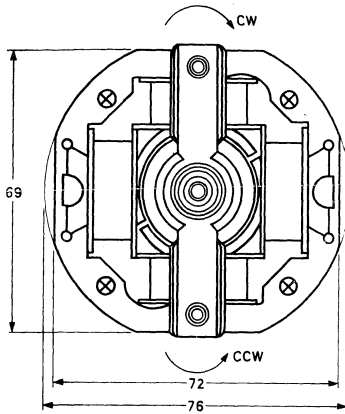

Connecting diagrams (view according to arrow P)

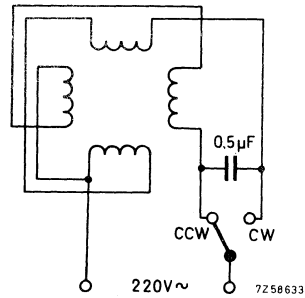
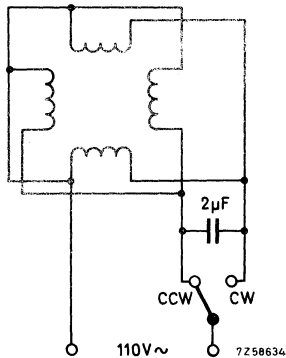

Weight

approx. 500 g

The values given below are measured at a nominal voltage of 220 V_{ac}; they apply to an ambient temperature of 22 ± 5 °C, an atmospheric pressure of 86-1060 mbar and a relative humidity of 45-75%. See also "Remarks".

Nominal voltage	110, 220 V _{ac}
Frequency	50 Hz
Starting torque at 150 rev/min	≥ 155 gcm*)
Maximum torque	≥ 155 gcm*)

*) 1 gcm ≈ 10⁻⁴ Nm

ASYNCHRONOUS MOTOR
with phasing capacitor

9904 123 01101

Speed at maximum torque	150 rev/min
at no load	≥ 2500 rev/min
at maximum output power	1800 rev/min
Maximum output power	≥ 2 W
Input power at no load	≤ 14 W
Current at no load	≤ 0.06 A
Direction of rotation	reversible, see dimensional drawing
Maximum permissible temperature	
of the windings	120 °C
of the bearings	90 °C
Minimum ambient temperature	-10 °C
Insulation according to IEC 65 and CEE 10	class E
Insulation test voltage	2500 V _{ac}
Bearings	self aligning slide bearings
Maximum radial force on the bearings	300 g*)
Maximum axial force	350 g*)
Maximum axial play	1.6 mm
Terminals	soldering tags
Required phasing capacitor	0.5 μF

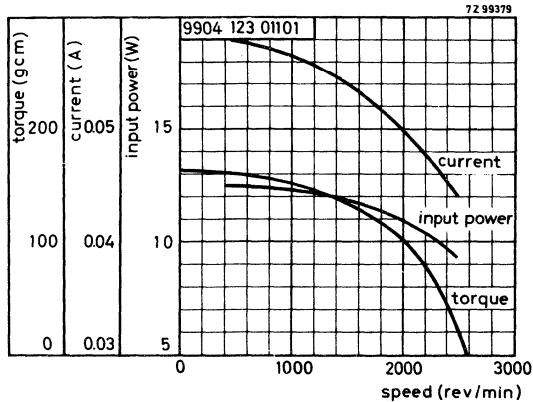

The curves are measured on an arbitrary motor.

*) 1 g ≈ 10⁻² N

REMARKS

- Input power, current and torque are measured at an ambient temperature of 20 °C, within the first 15 seconds after starting the cold motor. The speed is measured at an ambient temperature of 20 °C, 5 minutes after starting the cold motor.
- A voltage deviation of -10% from nominal causes the torque to decrease by about 20%.
- A capacitance deviation of the phasing capacitor of + or -10% from nominal causes the torque and the output power to increase or decrease respectively by about 10%.
- Versions for other supply voltages can be supplied on request.



ASYNCHRONOUS MOTOR with phasing capacitor

RZ 27077-9

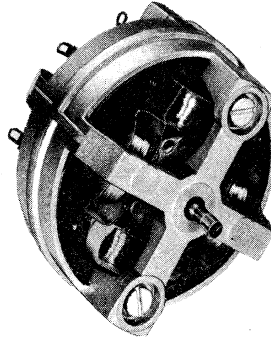

QUICK REFERENCE DATA

Nominal voltage	110, 220 V _{ac} , 50 Hz
Speed at no load	≥ 2800 rev/min
Input power at no load	≤ 45 W
Maximum torque	≥ 800 gcm *)

APPLICATION

- Industrial blowers and fans
- Office machines
- Vending machines

DESCRIPTION

This motor has a housing of die-cast aluminium. It has been provided with ball bearings.

*) 1 gcm ≈ 10⁻⁴ Nm

TECHNICAL DATA

Dimensions in mm

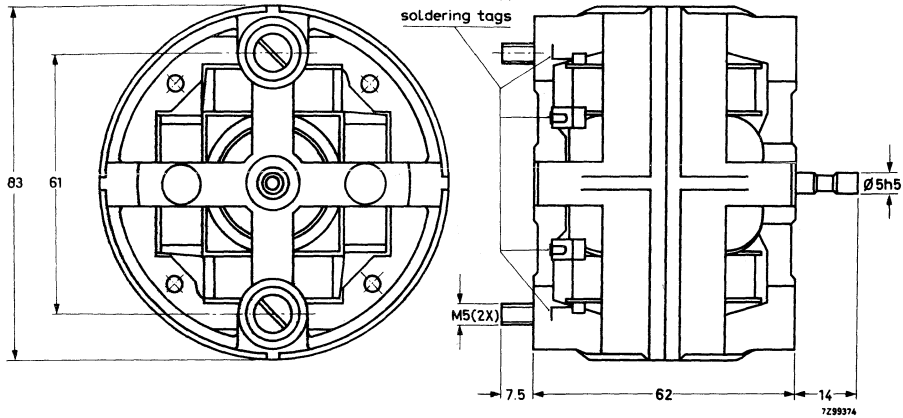

Connecting diagrams

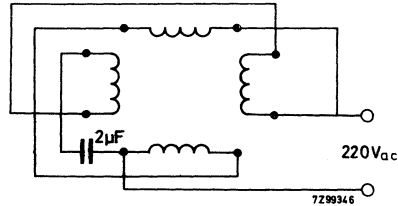
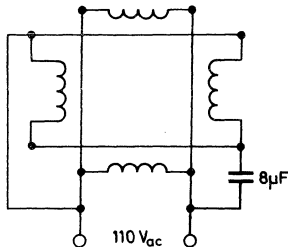

Weight

approx. 900 g

The values given below are measured at a nominal voltage of 220 V_{ac}; they apply to an ambient temperature of 22 ± 5 °C, an atmospheric pressure of 860 - 1060 mbar and a relative humidity of 45 - 75 %. See also "Remarks".

Nominal voltage

110, 220 V_{ac}

Frequency

50 Hz

Starting torque at 150 rev/min

≥ 550 gcm *)

Maximum torque

≥ 800 gcm *)

*) 1 gcm $\approx 10^{-4}$ Nm

Speed at maximum torque	2000 rev/min
at no load	≥ 2800 rev/min
at maximum output power	2200 rev/min
Maximum output power	≥ 17 W
Input power at no load	≤ 45 W
Current at no load	≤ 0.225 A
Direction of rotation	reversible
Maximum permissible temperature of the windings	120 °C
of the bearings	80 °C
Minimum ambient temperature	-10 °C
Insulation according to IEC 65	class E
Insulation test voltage	2500 V _{ac}
Bearings	ball bearings
Maximum radial force on the bearings	500 g *)
Maximum axial force	200 g *)
Maximum axial play	0.1 mm
Terminals	soldering tags
Required phasing capacitor	2 μF

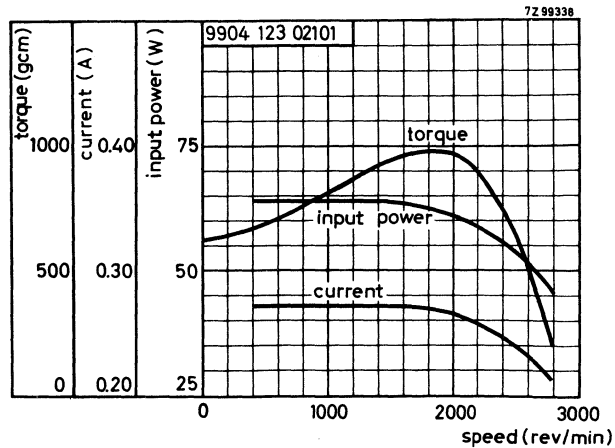

*) 1 g ≈ 10⁻² N

MOUNTING

The motor can be fixed by two screws M5.

REMARKS

- Input power, current and torque are measured at an ambient temperature of 20 °C, within the first 15 s after starting the cold motor.
The speed is measured at an ambient temperature of 20 °C, 5 min after starting the cold motor.
- A voltage deviation of -10% from nominal causes the torque to decrease by about 20%.
- A capacitance deviation of the phasing capacitor of + or -10% from nominal causes the torque and the output power to increase or decrease respectively by about 10%.
- Versions for other supply voltages can be supplied on request.



INDUSTRIAL CENTRIFUGAL BLOWER with asynchronous motor with phasing capacitor

RZ 27077-5

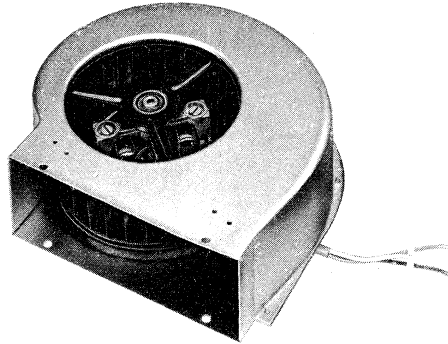

QUICK REFERENCE DATA

Nominal voltage	220 V, 50 Hz
Speed at maximum output power	2200 rev/min
Air displacement at an air pressure of 13 mm wg *)	130 m ³ /h

APPLICATION

For use in cooling systems requiring high static pressures to overcome airflow resistance such as in

- projector cooling
- heating convectors
- electronic equipment with high component density.

*) 1 mm wg = 1 kg/m²

DESCRIPTION

The industrial blower comprises a symmetrical asynchronous motor, catalogue number 9904 123 02101 with a enamelled steel vane wheel in a bright steel housing. A thermal safety switch has been provided.

TECHNICAL DATA

Dimensions in mm

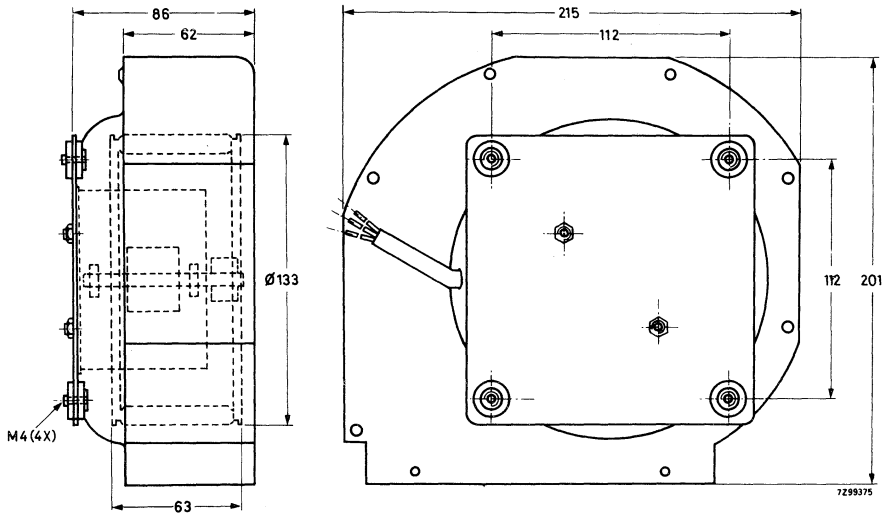

Connecting diagram

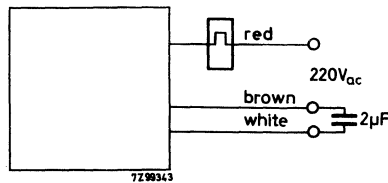

Weight	approx. 900 g
Nominal voltage	220 Vac
Frequency	50 Hz
Speed at maximum output power	2200 rev/min

Air displacement at an air pressure
of 13 mm wg *)

130 m³/h

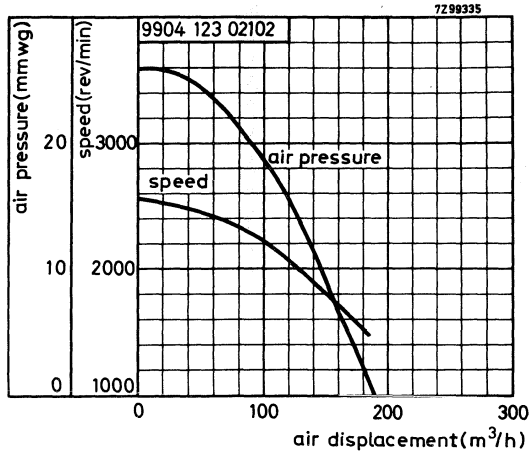

For full data of the motor see data sheets of the asynchronous motor 9904 123 02101.



*) 1 mm wg = 1 kg/m²

ASYNCHRONOUS MOTOR with phasing capacitor

RZ 27077-12

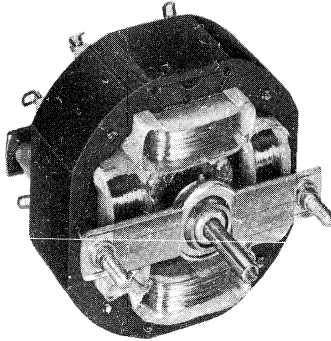

QUICK REFERENCE DATA

Nominal voltage	110, 220	V _{ac} , 50 Hz
Speed at no load	≥ 2650	rev/min
Input power at no load	≤ 27	W
Maximum torque	≥ 330	gcm *)

APPLICATION

- Office machines
- Vending machines
- Ventilators
- Domestic appliances

DESCRIPTION

This asynchronous motor has been provided with two spindle ends. It has two threaded ends for mounting. The motor is suitable for tropical environments.

*) 1 gcm $\approx 10^{-4}$ Nm

TECHNICAL DATA

Dimensions in mm

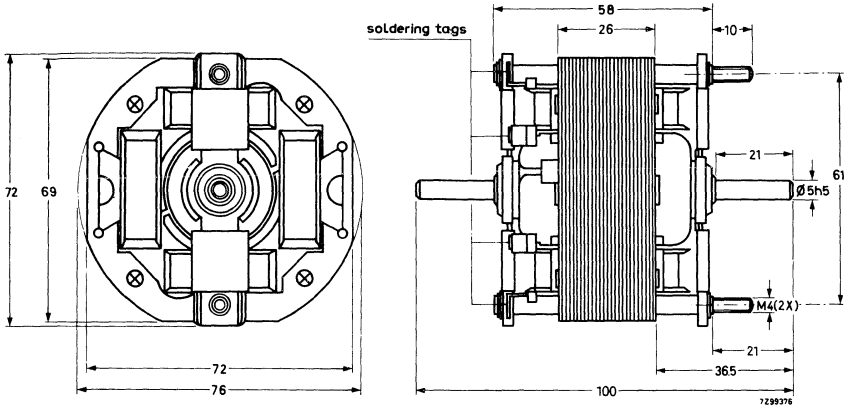

Connecting diagrams

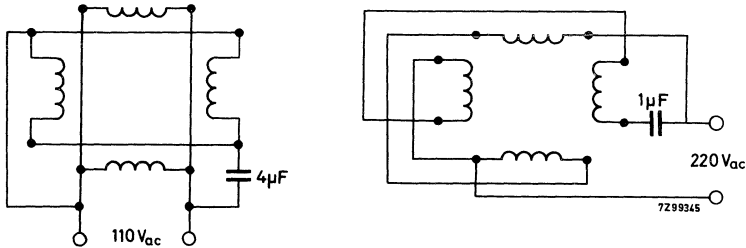

Weight

approx. 780 g

The values given below are measured at a nominal voltage of 220 V_{ac}; they apply to an ambient temperature of 22 ± 5 °C, an atmospheric pressure of 860 - 1060 mbar and a relative humidity of 45 - 75%. See also "Remarks".

Nominal voltage	110, 220 V _{ac}
Frequency	50 Hz
Starting torque at 150 rev/min	≥ 280 gcm ^{*)}
Maximum torque	≥ 330 gcm ^{*)}

*)1 gcm ≈ 10⁻⁴Nm

MOUNTING

The motor can be fixed by means of two screws M4.

REMARKS

- Input power, current and torque are measured at an ambient temperature of 20 °C, within the first 15 s after starting the cold motor.
The speed is measured at an ambient temperature of 20 °C, 5 min after starting the cold motor.
- A voltage deviation of -10% from nominal causes the torque to decrease by about 20%.
- A capacitance deviation of the phasing capacitor of + or - 10% from nominal causes the torque and the output power to increase or decrease respectively by about 10%.
- Versions for other supply voltages can be supplied on request.



ASYNCHRONOUS MOTOR with phasing capacitor

RZ 27077-2

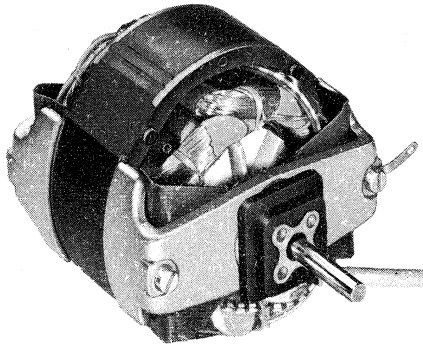

QUICK REFERENCE DATA

Nominal voltage	110, 220 V, 50 Hz
Speed at no load	≥ 2900 rev/min
Input power at no load	≤ 40 W
Maximum torque	≥ 1150 gcm *)

APPLICATION

The motor is intended for use in

- professional sound and picture recording instruments
- medical equipment
- computer peripherals.

DESCRIPTION

This reversible asynchronous motor with phasing capacitor has a high output power and a high efficiency. Mechanical noise has been restricted by special spindle treatment and severe tolerances on the self-adjusting slide bearings. Motor vibrations are absorbed by rubber suspension blocks. It is suitable for tropical environments.

*) 1 gcm $\approx 10^{-4}$ Nm

TECHNICAL DATA

Dimensions in mm

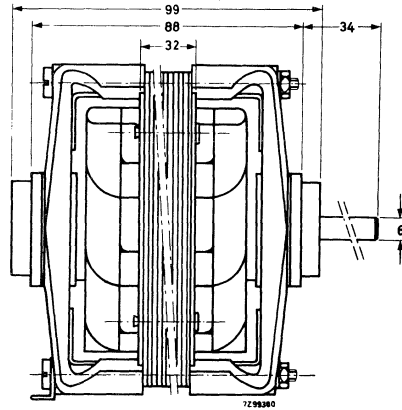
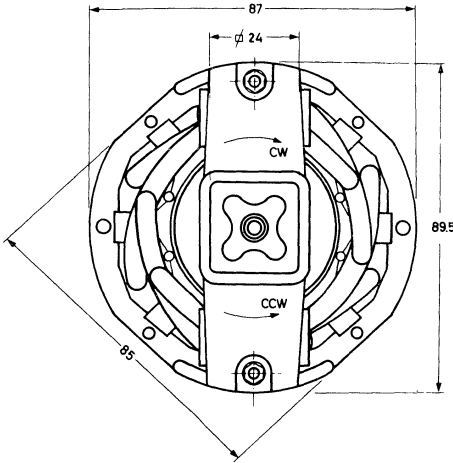

Connecting diagrams

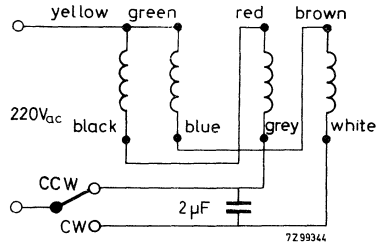
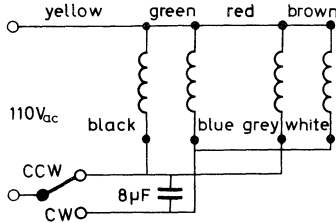

Weight

approx. 1650 g

The values given below are measured at a nominal voltage of 220 Vac; they apply to an ambient temperature of 22 ± 5 °C, an atmospheric pressure of 860-1060 mbar and a relative humidity of 45 - 75%. See also "Remarks".

Nominal voltage

110, 220 Vac

Frequency

50 Hz

Starting torque at 150 rev/min

≥ 450 gcm *)

Maximum torque

≥ 1150 gcm *)

*) 1 gcm $\approx 10^{-4}$ Nm

MOUNTING

The motor can be fixed by means of the rubber suspension blocks.

REMARKS

- 1) Input power, current and torque are measured at an ambient temperature of 20 °C, within the first 15 s after starting the cold motor.
The speed is measured at an ambient temperature of 20 °C, 5 min after starting the cold motor.
- 2) A voltage deviation of -10% from nominal causes the torque to decrease by about 20%.
- 3) Versions for other supply voltages can be supplied on request.
- 4) A capacitance deviation of the phasing capacitor of +or -10% from nominal causes the torque and the output power to increase or decrease respectively by about 10%.



II TIMING AND CONTROL DEVICES

(A.W. HAYDON)

Indicators for built-in test equipment (bite)

General	page F3
Rectangular BITE indicators	page F9
Round BITE indicators	page F15
Ball BITE indicators	page F19



INTRODUCTION

Our range of microminiature BITE indicators enables performance monitoring to be achieved with ease. Functionally, these units monitor the performance of a system and/or its components and provide an automatic visual warning whenever equipment operation falls outside of the design parameters, and will continue to indicate the fault condition even after loss of power. Microminiature BITE indicators may be employed at system, sub-system, module and printed circuit board levels.

Of course, indicators need not only be fitted into the various parts of a system. Signals or functions to be monitored can also be parallel-wired to indicators grouped on a conveniently placed panel where they will come under the routine inspection of an alert equipment operator. Such a fault isolation system (FIS) further increases fault detection speed and equipment efficiency.

Polymotor -A. W. Haydon offer three basic types of BITE indicators - ball, round, and rectangular. It is envisaged that the ball type will find the majority of its applications in industry, whilst the round and rectangular types will be more suited to military uses.

In addition to the three basic BITE indicator types, Polymotor -A. W. Haydon can provide test and driver circuits for applications where customer's circuitry does not provide the characteristics needed to operate the indicator in the desired manner. Examples of this are where the fault signal is in the millivolt range or in a pulse form lasting only microseconds, or where a time delay is required before the indicator operates. In most cases these circuits can be included as part of the indicator package and are often incorporated into the basic indicator assembly without increasing its size. Consultation with our engineers, early in the equipment design stage, will realize the maximum benefits in performance and design simplification, and in size, weight and cost reduction.

MAIN APPLICATIONS

FAULT DETECTION

Ball type

The microminiature size of the ball BITE indicator permits direct mounting onto printed circuit boards as well as surface or panel mounting in such equipment as:

recorders; indicators; amplifiers; annunciators; auxiliary devices.

Simplified design and functional utilization make these units ideal for use with automatic control and systems in the process industry.

Round and rectangular types

Military applications utilizing the round and rectangular types include many avionic systems where rapid in-flight fault detection is of the utmost importance, and where in-flight history is required by ground maintenance crews. Some avionic applications are given below.

- In-flight monitoring of the voltage and frequency output of 400 Hz alternators is done by sensors which send signals to the BITE indicators. The indicators' magnetic latching properties enable ground maintenance crews to tell at a glance whether the alternators functioned properly during the flight, and to take any necessary corrective action.
- Servo loop in an aircraft control system. In this application the indicator has a built-in time delay. When a control signal is applied to the system, the indicator detects any failure to respond within 10 ms, after which time the delay triggers the BITE indicator to signal an actual or potential failure.
- Ground-support computer equipment. The indicator monitors the complement of the output code continuously and signals if an erroneous code is generated.
- Aircraft fire warning system. Each of a number of indicators in the pilots' compartment represents a different section of the aircraft and, in the event of fire, the pilot can determine its location immediately. It is extremely important that a fault indicator continues to register upon the loss of power, therefore indicating lights can not even be considered for such a use.
- Automatic Landing System (ALS) in one of the major commercial aircraft. In each system 24 indicators are used to monitor various components. Immediately prior to landing, a complete check of the aircraft's landing system is made automatically, three times, and everything must be in a "go" condition before an actual landing is made.

FAULT ISOLATION

The fault isolation system (FIS) grew from the necessity for one-location performance monitoring of large-scale electronic and avionic concepts. No matter how complex or sophisticated the equipment under scrutiny, a well-designed FIS will give an at-a-glance performance statement - BITE indicators are the heart of any FIS - they make the performance statement.

Any out-of-tolerance parameter capable of being converted into a fault signal voltage level can be monitored, be it continuous, pulse, or transient in nature. Commercial and military application for FIS are many and varied (the FIS meets all military specifications, particularly MIL-E-5400 and MIL-STD-810). Among the many applications, a few of the more obvious are:

- commercial and military aircraft;
- computer systems;
- industrial and process control;
- qualification and verification testing.

A complete FIS consists of an annunciator panel containing any number of electrically-actuated BITE indicators, signal conditioning and control/comparator network circuitry. A self-test capability can also be incorporated to verify BITE indication and circuit operation. K21500, K21600 and K21700 series BITE indicators have been specifically designed to interface with the FIS signal conditioning circuitry (low voltage d.c. signal operation).

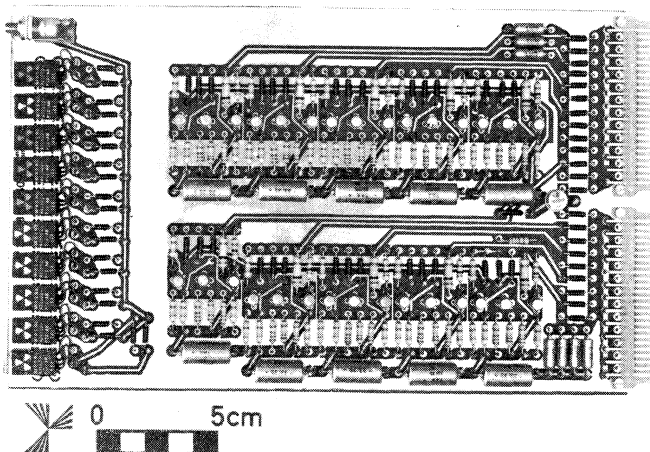

FIS can be small too. The photograph shows a fault isolation concept applied to a printed circuit board used in telecommunication equipment. Ten rectangular BITE indicators are mounted on the left of the board.

(Photograph by courtesy of Standard Elektrik Lorenz, Stuttgart, West Germany).

A FIS is as individual as the customer's requirement and Polymotor-A. W. Haydon have experienced engineers on hand to assist in realizing specific requirements (also those relating to military and standard ARINC specifications).

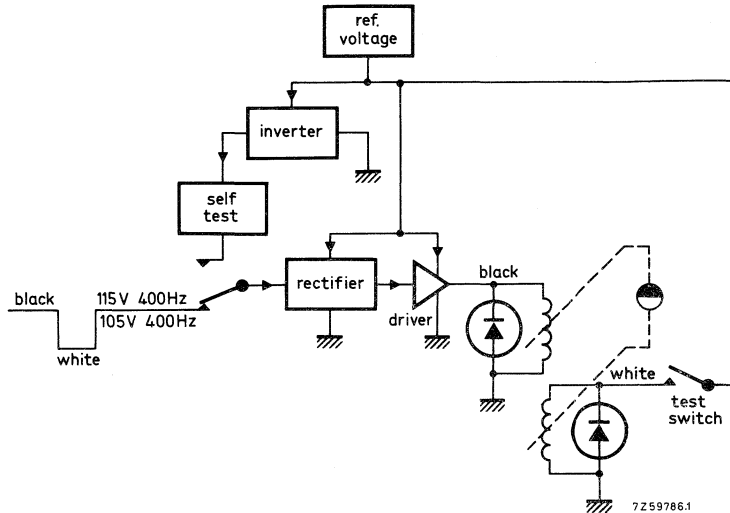

Typical FIS circuitry required to actuate a BITE indicator when the input signal is a.c.

RECTANGULAR BITE INDICATORS

RZ 29167-5

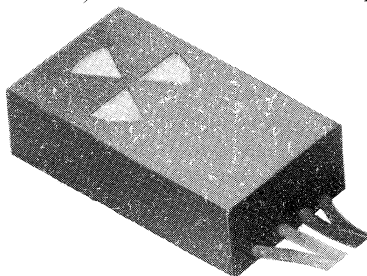

DESCRIPTION

Fault indication is made visually through windows on the front and/or side of the unit.

MECHANICAL DATA

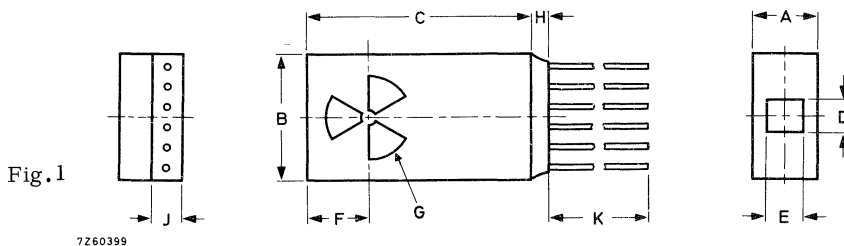

dim.	mm	in
A	5.08	0.200
B	10.16	0.400
C	17.78	0.700
D	2.59 min.	0.102 min.
E	2.84 min.	0.112 min.
F	4.76	3/16
G	7.14 diam.	9/32 diam.
H	1.58 max.	1/16 max.
J	2.54 max.	0.100 max.
K	203.2 min.	8.0 min.

Readout	front, normal - black; fault - white
Enclosure	side, normal - black; fault - white cloverleaf
Finish	sealed plastic housing
Leads	black acrylic paint
	30 AWG stranded and insulated (1 to 5 leads);
	32 AWG stranded and insulated (6 leads)
Weight	6 nom.

ELECTRICAL DATA

Operating voltage	28 V d. c.
Coil resistance	min. 1400 Ω at 25 °C
Duty rating	intermittent
Duty cycle	20 % over voltage and temperature range
Cycle rate	max. 10 Hz
Input signal duration	min. 15 ms; max. 1 s (non-switched coils)

Diagrams and connections

The following five versions are available:

Version - P13

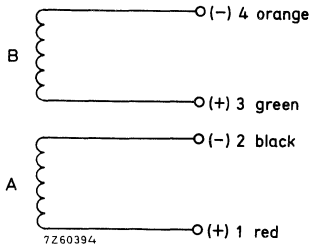

Non-switched unit; requires pulse input. When coil A is energized with the polarity indicated, the device will transfer from black to a white cloverleaf and latch in this condition. When coil B is energized the readout will transfer from white cloverleaf to black and latch.

Fig. 2
(a)

Version - P23

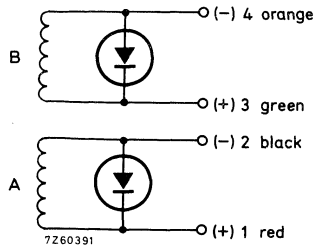

Non-switched unit with internal diode suppression of inductive load; requires pulse input. Operates in same manner as P13.

(b)

Version - P33

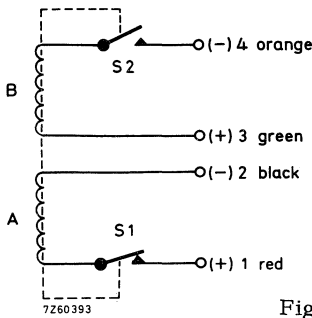
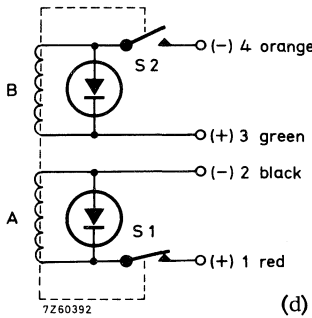

Fig. 2
(c)

Self-switched unit; uses power during transition only. When coil A is energized with the polarity indicated, the device will transfer from black to a white cloverleaf; close S₂ to make ready condition for coil B operation; open S₁ removing power from coil A, and latch in this condition. When coil B is energized the readout will transfer from white cloverleaf to black and latch, with the reverse switching sequence.

Version - P43



(d)

Self-switched unit with internal contact protection; uses power during transition only. Operates in same manner as P33.

Version - P63

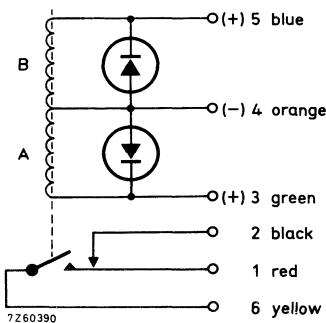

(e)

Relay unit with internal diode suppression of inductive load; requires pulse input when not self-switched. (Switch: Form D - make occurs approx. 6 ms before break - rated 20 mA resistive at 28 V d.c.)

When coil A is energized with the polarity indicated, the device will transfer from black to a white cloverleaf; make the circuit between terminals 1 and 6; break the circuit between terminals 2 and 1, and latch in this condition. When coil B is energized, the readout will transfer from white cloverleaf to black and latch, with the reverse switching sequence.



MILITARY TESTS

The indicators withstand the following tests:

tests	MIL -E -5400H paragraph 1)	comments
high temperature	3. 2. 21. 1	105 °C operating and non-operating
low temperature	3. 2. 21. 1	-54 °C operating and non-operating
temperature shock	3. 2. 21. 1. 1	non-operating
altitude	3. 2. 21. 2	9140 m
humidity	3. 2. 21. 4	
vibration	3. 2. 21. 5	curves I and III 15 g to 500 Hz
shock	3. 2. 21. 6	30 g for 11 ms
sand and dust	3. 2. 21. 7	
fungus	3. 2. 21. 8	
salt spray	3. 2. 21. 9	48 h
explosive conditions	3. 2. 21. 10	
transient voltage	N/A	80 V d. c. max.

1) Class 1 A equipment

MOUNTING

The indicators can be supplied mounted on the bracket of Fig. 3 in four different positions as shown in Fig. 4 a, b, c, d, distinguished by mounting numbers. When an indicator is supplied without a bracket (or with the bracket separate), a 100% epoxy adhesive should be used to fasten the indicator to the chassis (or to the bracket). Adhesives containing diluents or volatiles are to be avoided as indicator damage may result.

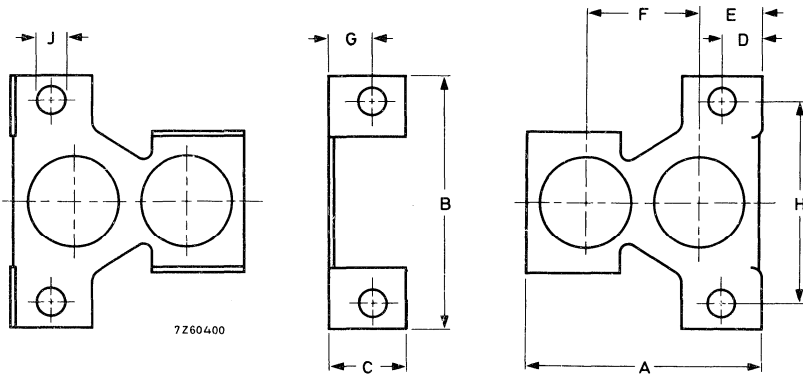
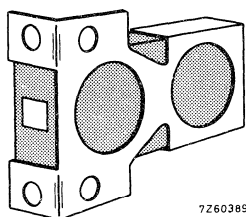
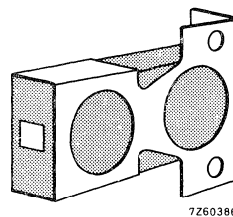

Fig. 3. Dimensional drawing of mounting bracket
(mounting number for separate delivery-10)

dim.	mm	in
A	18.65	47/64
B	19.84	25/32
C	5.95	15/64
D	3.17	0.125
E	4.88 - 5.08	0.192 - 0.200
F	8.89	0.350
G	3.35	0.132
H	15.87	0.625
J	2.36 $\left\{ \begin{array}{l} +0.12 \\ -0.00 \end{array} \right.$	0.093 $\left\{ \begin{array}{l} +0.005 \\ -0.000 \end{array} \right.$



a (mounting number -11)



b (mounting number -12)

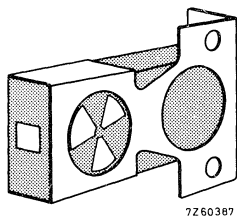

c (mounting number -13)

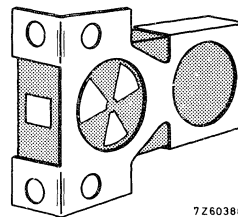

d (mounting number -14)

Fig. 4. Indicator mounted on the bracket in four different positions.

ORDERING

Please quote the model number, version number, and mounting number (if applicable). Special windings, and different readout colours are available on request. Special mountings can be made to order.

ROUND BITE INDICATORS

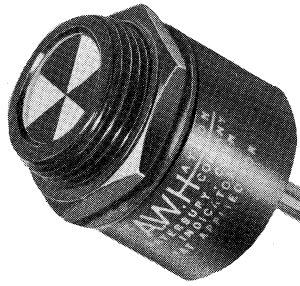

RZ 29167-4

DESCRIPTION

Fault indication is made visually through a window on the front of the unit. An important feature of the round type of BITE indicators is the use of mechanical latching in addition to magnetic latching which further ensures against false transfer when indicators are subjected to severe shock or vibration.

MECHANICAL DATA

Model K21602 Front panel mounting

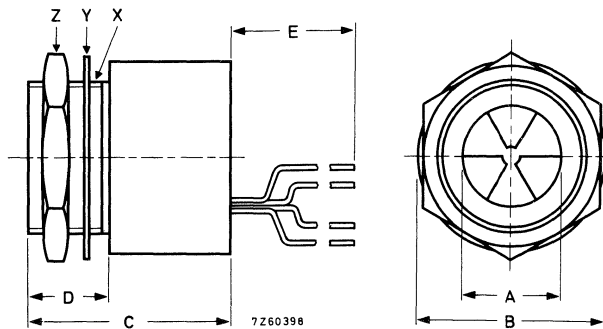

Dimensions

	mm	in.	
A	7.92	0.312	X 11.9 mm (15/32 in) - 32 pitch thread to within 1.58 mm (1/16 in) of shoulder
B	15.07	0.593	Y washer 15.9 mm (5/8 in) outer dia, 0.51 mm (0.02 in) thick
C	16.00 max.	0.630 max.	Z hexagonal nut 14.3 mm (9/16 in) across flats, 2 mm (5/64 in) thick
D	6.35	0.250	
E	203.2 min.	8.0 min.	

Readout	normal - black; fault - white cloverleaf
Enclosure	sealed aluminium housing
Finish	black anodized housing; black Ebanol C nut; black oxide lock washer.
Leads	30 AWG stranded and insulated (4 leads)
Weight	13 g nom.

ELECTRICAL DATA

Operating voltage	28 V d.c.
Coil resistance	min. 600 Ω at 25°C
Duty rating	intermittent
Duty cycle	12.5% over voltage and temperature range
Cycle rate	max. 10 Hz
Input signal duration	min. 50 ms max. 10 s

Diagrams and connections

A version without and a version with diodes for suppression of inductive loads are available:

Version - P13

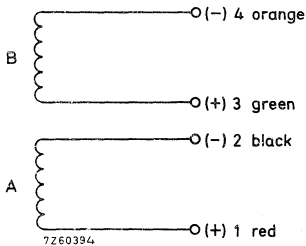

Version - P23

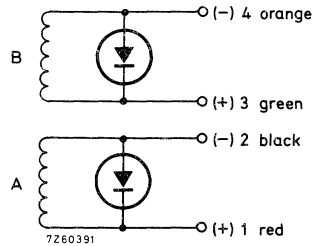

When coil A is energized with the polarity indicated, the device will transfer from black to white cloverleaf readout and latch in this condition. When coil B is energized, the device will transfer from white cloverleaf to black readout and latch.

MILITARY TESTS

The indicators withstand the following tests:

tests	MIL-E-5400H paragraph 1)	comments
high temperature	3.2.21.1	85 °C operating; 95 °C non-operating
low temperature	3.2.21.1	-54 °C operating; -65 °C non-operating
temperature shock	3.2.21.1.1	non-operating
altitude	3.2.21.2	9140 m
humidity	3.2.21.4	
vibration	3.2.21.5	20 g to 2 kHz (exceeds MIL-E-5400)
shock	3.2.21.6	exceeds MIL-E-5400 2)
sand and dust	3.2.21.7	
fungus	3.2.21.8	
salt spray	3.2.21.9	48 h
explosive conditions	3.2.21.10	
transient voltage	N/A	80 V d. c. max.

1) Class 1 A equipment

2) Highest shock limit before false transfer occurs has not been determined. Units have been tested successfully at 100 g for 9 ms and 590 g for 2 ms - 3 shocks in each direction in 3 mutually perpendicular planes at both g levels - total of 36 shocks.

ORDERING

Please quote K21602-P13 or K21602-P23, as required. Other readout colours are available on request.



BALL BITE INDICATORS

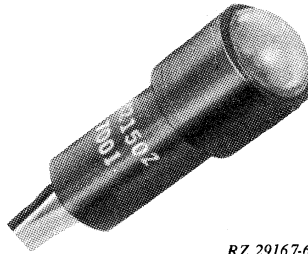

RZ 29167-6

DESCRIPTION

For functional display, the ball type of BITE indicator makes use of a pivoted two-colour ball which has a permanent magnet core. When a fault signal is applied to one coil, a magnetic field is generated in opposition to the magnetic polarity of the ball forcing it to pivot; its permanent magnet core then aligns with the field generated by the coil. A reset signal applied to the other coil will initiate the reverse action*).

MECHANICAL DATA

The following 3 models are available:

Model K21702, Press-fit panel mounting

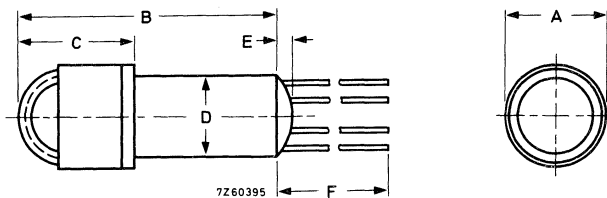

Fig.1

dim.	mm	in
A	8.13	0.320
B	20.62	0.812
C	9.22	0.363
D	6.35 diam.	0.250 diam.
E	1.27 max.	0.050 max.
F	203.2 min.	8.0 min.

*) Units are being developed which will include a manual reset as well as the electrical reset.

Model K21702-M1, Front panel mounting

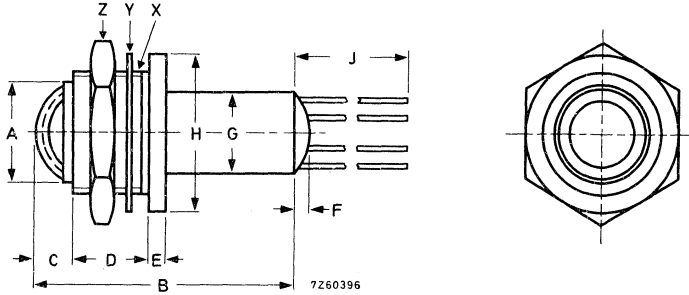

Fig. 2

7260396

Model K21702-M2, Rear panel mounting

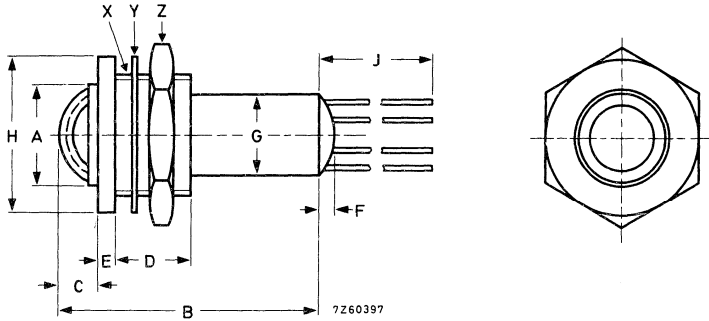

Fig. 3

7260397

Dimensions Figs.2 and 3

	mm	in	
A	7.62 diam.	0.30 diam.	
B	21.08 max.	0.83 max.	X 9.5 mm (3/8 in) - 32 NEF thread
C	3.05	0.12	to within 1.58 mm (1/16 in) of
D	6.35	0.25	shoulder
E	1.52	0.06	
F	1.52 max.	0.06 max.	Y washer 12.7 mm (1/2 in) outer dia,
G	6.35 diam.	0.25 diam.	0.51 mm (0.02 in) thick
H	12.7 diam.	0.50 diam.	Z hexagonal nut 12.7 mm (1/2 in)
J	203.2 min.	8.0 min.	across flats, 2 mm (0.08 in) thick

Readout	normal - black; fault - white
Enclosure	sealed aluminium housing
Finish	black anodizing
Leads	30AWG stranded and insulated (4 leads)
Weight	4 g max.

ELECTRICAL DATA

Operating voltage	28 V d.c.
Power	0.5 W nom.
Duty rating	intermittent
Duty cycle	6% over voltage and temperature range
Cycle rate	max. 4 Hz
Input signal duration	min. 50 ms

Diagram and connections

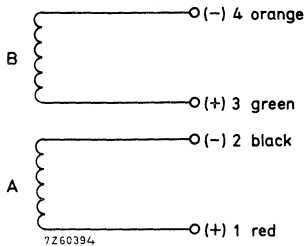

When coil A is energized with the polarity indicated, the device will transfer from black to white readout and latch in this condition. When coil B is energized, the device will transfer from white to black and latch.

MILITARY TESTS

The indicators withstand the following tests:

tests	MIL-E-5400H paragraph ¹⁾	comments
high temperature	3.2.21.1	95 °C operating; 125 °C non-operating (or as function of mounting heat sink)
low temperature	3.2.21.1	-54 °C operating; -65 °C non-operating
temperature shock	3.2.21.1.1	non-operating
altitude	3.2.21.2	9140 m
humidity	3.2.21.4	100% for 240 h
vibration	3.2.21.5	10 g to 500 Hz ²⁾
shock	3.2.21.6	30 g for 11 ms
sand and dust	3.2.21.7	
fungus	3.2.21.8	
salt spray	3.2.21.9	48 h
explosive conditions	3.2.21.10	

1) Class 1 A equipment

2) The indicator should be shielded from the vibrator's magnetic field.

ORDERING

Please quote the model number for ordering. Continuous duty cycle, and different readout colours are available on request.

**Time indicators,
timers and timing motors**



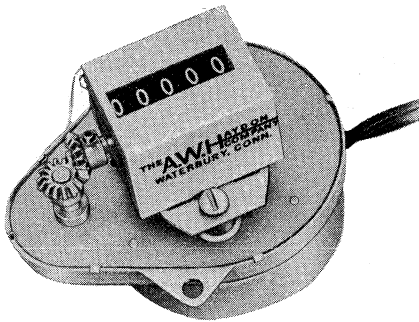

Basic elapsed time indicator

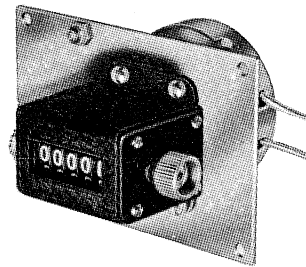

Resettable elapsed time indicator

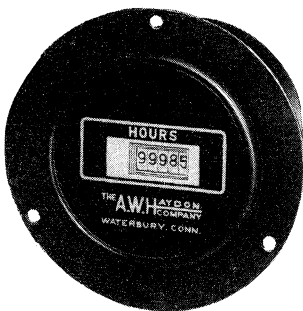

Hermetically-sealed elapsed time indicator

TIME INDICATORS

Basic Elapsed Time Indicators (ETI)

Resettable ETI

Hermetically-Sealed ETI

Hermetically-Sealed Resettable ETI

Commercial ETI

Industrial ETI

Microminiature ETI

Microminiature Resettable ETI

Microminiature Industrial ETI

Subminiature ETI

Microminiature Non-Reset Events Counters

Microminiature Reset Events Counters

Electro-Mechanical Counters

Laboratory Stop Clocks

Stop Clocks

Information on these devices can for the time being be found in our booklet "Timing and control devices", order No 9399 173 06329, which is available on request.

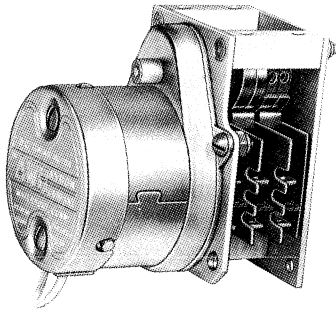

Basic repeat cycle timer

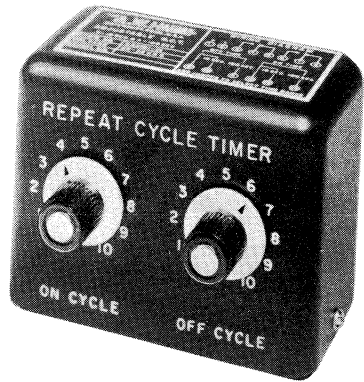

Electronic repeat cycle timer

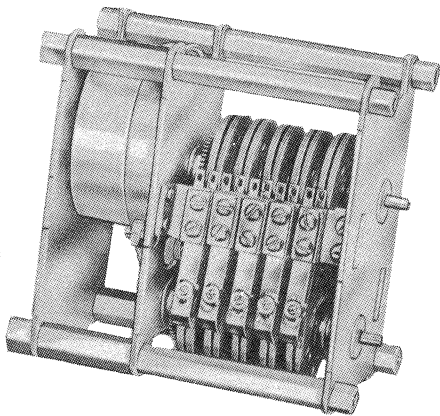

Precision repeat cycle timer

TIMERS

Basic Repeat Cycle Timers
Electronic Repeat Cycle Timers
Precision Repeat Cycle Timers
Commercial/Industrial Repeat Cycle Timer
Subminiature Repeat Cycle Timers
Progress-Indicating Delay Relays
Delay Relays
Subminiature Delay Relays
Electronic Industrial Delay Relays
Electronic Delay Relays
Crystal Can Timing Module
Electronic Timing Modules
Electronic Time Code Generator
Electro-mechanical Time Code Generators
Motor-driven Potentiometers
Rotary Stepping Switch
Interrupters

Information on these devices can for the time being be found in our booklet "Timing and control devices", order No 9399 173 06329, which is available on request.

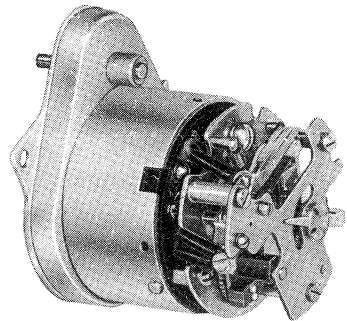
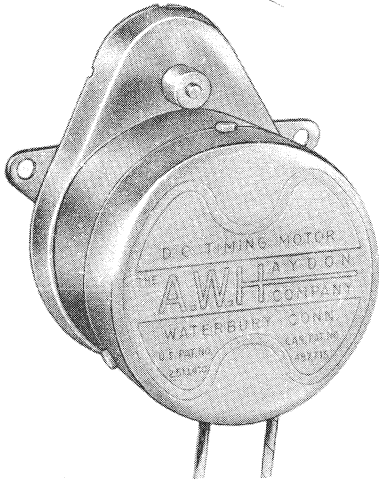

Chronometrically-governed d. c. motor

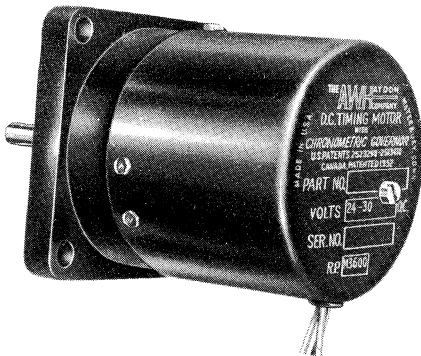

High-performance governed d. c. motor

TIMING MOTORS

D. C. Motors

Chronometrically Governed D. C. Motors

High-Performance Governed D. C. Motors

Miniature D. C. Motor

Hysteresis Synchronous Motors

Miniature 400 Hz Timing Motor

Shaded-Pole Synchronous Motors

Miniature Reversible Synchronous Motor

General Duty Synchronous Motor

High-Torque Reversible Synchronous Motor

Information on these devices can for the time being be found in our booklet "Timing and control devices", order No 9399 173 06329, which is available on request.

Contents

SECTION I

		page
SMALL SYNCHRONOUS MOTORS		
Principles		A3
Quality control		A13
Life		A15
Reliability		A15
Applications		A16
Remarks on the technical data		A18
Unidirectional motors	9904 110	A19
Reversible motors	9904 111	A29
Synchrodrivers	9904 115	A45
A.C./D.C. synchronous motors		A51
Universal programme switch assembly kit	9904 131 02001	
	9904 131 02002	A57
	9904 130 01...	A61
Gearboxes		
STEPPER MOTORS		
Introduction		B3
Principles		B5
Terminology		B9
Characteristics		B11
Applications		B13
Stepper motor	9904 112 04101	B15
Stepper motor	9904 112 05101	B19
Stepper motor	9904 112 06101	B23
Stepper motor	9904 112 07101	B27
Stepper motor	9904 112 08101	B31
Stepper motors	9904 112 10001	
	9904 112 11001	B35
	9904 112 12001	
Stepper motors	9904 112 13001	B41
	9904 112 14001	
Stepper motors	9904 112 15001	B47
	9904 112 16001	
Stepper motors	9904 112 17001	B53
	9904 112 18001	
Stepper motors	9904 112 19001	B59
	9904 112 20001	
Stepper motors	9904 112 21001	B65
	9904 112 22001	
Stepper motors	9904 112 23001	B71

Stepper motors	9904 112 24001	page
	9904 112 25001	B77
Electronic switch for 4-phase stepper motors	9904 131 03003	B84
Electronic switch for 8-phase stepper motors	9904 131 03004	B89
SMALL D.C. MOTORS		
<u>Governed d.c. motors</u>		
Applications		C3
Direct current motors in deep drawn metal housing	9904 120 01501	C5
Direct current motor with interference-suppression filter	9904 120 01502	C9
Direct current motor	9904 120 03101	C13
Direct current motors with reduction	9904 120 53...	C17
Electronic speed control for direct current motors	9904 132 01006	C23
<u>Ungoverned d.c. motors</u>		
Direct current motors	9904 120 07...	
	9904 120 08...	C29
Direct current motors with reduction	9904 120 514..	
	9904 120 516..	C33
Direct current motor drive unit with integrated gearbox	9904 120 54301	C41
TACHOGENERATORS AND SERVOMOTORS		
Servomotor, symmetric asynchronous type with a.c. tachogenerator	9904 121 00011	D3
D.C. tachogenerators	9904 121 000..	D9
ASYNCHRONOUS MOTORS		
Introduction		E3
Asynchronous motor symmetric, shaded pole type, with fan	9904 122 01311	E5
Asynchronous motor symmetric, shaded pole type	9904 122 02311	E9
Asynchronous motor asymmetric, shaded pole type	9904 122 03141	E13
Asynchronous motor asymmetric, shaded pole type	9904 122 04101	E17

		page
Asynchronous motor		
asymmetric, shaded pole type	9904 122 05311	E21
Asynchronous motor		
symmetric, shaded pole type	9904 122 06101	E25
Asynchronous motor		
symmetric, shaded pole type, with fan	9904 122 06102	E29
Asynchronous motor		
with phasing capacitor	9904 123 01101	E33
Asynchronous motor		
with phasing capacitor	9904 123 02101	E37
Industrial centrifugal blower with		
asynchronous motor with phasing capacitor	9904 123 02102	E41
Asynchronous motor		
with phasing capacitor	9904 123 03101	E45
Asynchronous motor		
with phasing capacitor	9904 123 04301	E49

SECTION II

INDICATORS FOR BUILT-IN TEST EQUIPMENT (BITE)

Introduction	F3
Main applications	F5
Rectangular BITE indicators	F9
Round BITE indicators	F15
Ball BITE indicators	F19

TIME INDICATORS, TIMERS AND TIMING MOTORS

Time indicators	G3
Timers	G5
Timing motors	G7

I "Electric motors and accessories" (Polymotor)

A Small synchronous motors

B Stepper motors

C Small d.c. motors

D Tachogenerators and servomotors

E Asynchronous motors

II "Timing and control devices" (A.W. Haydon)

F Indicators for built-in test equipment (bite)

G Time indicators, timers, timing motors

